

## 前 言

本零件图册适用于 HD32 型推土机。

发动机所属零件，详见发动机零件目录。

因产品改进所增减的零件，不再通知，请用户谅解。

## FOREWORD

This Parts Book is applicable to the HD32 bulldozer.

See list of the engine's parts for details about the engine's parts.

Parts increased or decreased due to product improvement will not be notified separately.

We are sorry for the inconvenience.

## 目 录

发动机关联部件.....	1
<b>ENGINE RELATED PARTS.....</b>	<b>1</b>
发动机安装.....	2
ENGINE MOUNTING.....	2
分动箱.....	4
TRANSFER CASE.....	4
分动箱.....	6
TRANSFER CASE.....	6
飞轮壳总成.....	8
FLYWHEEL HOUSING ASS'Y.....	8
出力装置.....	10
POWER TAKE OFF.....	10
出力装置.....	12
POWER TAKE OFF.....	12
出力装置润滑管.....	14
PTO LUBRICATING OIL PIPING.....	14
前支架.....	16
FRONT BRACKET.....	16
排气管与消声器.....	18
EXHAUST PIPE AND MUFFLER.....	18
空气滤清器与罩.....	20
AIR CLEANER AND CAP.....	20
排气管与消声器（配国 II 发动机）.....	22
EXHAUST PIPE AND MUFFLER (GOING WITH THE NATIONAL II-ENGINE).....	22
空气滤清器与罩（配国 II 发动机）.....	24
AIR CLEANER AND CAP (GOING WITH THE NATIONAL II-ENGINE).....	24
燃油操纵杆.....	26
FUEL CONTROL LEVER.....	26
燃油操纵连杆机构.....	28
FUEL CONTROL LINKAGE.....	28
减速踏板.....	30
DECELERATOR PEDAL.....	30
风扇.....	32
FAN.....	32

散热器.....	34
RADIATOR.....	34
散热器.....	36
RADIATOR.....	36
散热器风扇防护网罩.....	38
RADIATOR FAN GUARD AND NET.....	38
散热器风扇防护网罩.....	40
RADIATOR FAN GUARD AND NET.....	40
散热器及其管路（配国Ⅱ发动机）.....	42
RADIATOR AND PIPING (GOING WITH THE NATIONAL II-ENGINE).....	42
散热器及其管路（配国Ⅱ发动机）.....	44
RADIATOR AND PIPING (GOING WITH THE NATIONAL II-ENGINE).....	44
散热器及其管路（配国Ⅱ发动机）.....	46
RADIATOR AND PIPING (GOING WITH THE NATIONAL II-ENGINE).....	46
油冷器总成.....	48
OIL COOLER ASS'Y.....	48
燃油箱.....	50
FUEL TANK.....	50
燃油管路.....	52
FUEL PIPING.....	52
加油泵总成.....	54
FILLING PUMP ASS'Y.....	54
<b>变矩器和变速箱.....</b>	<b>57</b>
<b>TORQUE CONVERTOR AND TRANSMISSION.....</b>	<b>57</b>
万向节.....	58
UNIVERSAL JOINT.....	58
变矩器外壳与阀.....	60
TORQUE CONVERTER HOUSING AND VALVE.....	60
变矩器外壳与阀.....	62
TORQUE CONVERTER HOUSING AND VALVE.....	62
涡轮导向器.....	64
TURBINE AND STATOR.....	64
涡轮导向器.....	66
TURBINE AND STATOR.....	66
变速箱壳.....	68
TORQUE TRANSMISSION CASE.....	68
变速箱齿轮与轴（1/2）.....	70

TRANSMISSION GEAR AND SHAFT (1/2) .....	70
变速箱齿轮与轴 (1/2) .....	72
TRANSMISSION GEAR AND SHAFT (1/2) .....	72
变速箱齿轮与轴 (2/2) .....	74
TRANSMISSION GEAR AND SHAFT (2/2) .....	74
变速箱齿轮与轴 (2/2) .....	76
TRANSMISSION GEAR AND SHAFT (2/2) .....	76
变速箱.....	78
TRANSMISSION CASE.....	78
变速阀.....	80
TRANSMISSION CONTROL VALVE.....	80
变速阀.....	82
TRANSMISSION CONTROL VALVE.....	82
盖与阀控制杆.....	84
COVER AND VALVE CONTROL LEVER.....	84
润滑阀.....	86
LUBRICATING VALVE.....	86
变速操纵杆 (1/2) .....	88
GEAR SHIFT LEVER (1/2) .....	88
变速操纵杆 (1/2) .....	90
GEAR SHIFT LEVER (1/2) .....	90
变速操纵杆 (2/2) .....	92
GEAR SHIFT LEVER (2/2) .....	92
变速油泵.....	94
TRANSMISSION PUMP.....	94
精滤器总成.....	96
FINE FILTER ASS'Y.....	96
变矩器管路系统.....	98
TORQUE CONVERTER PIPING SYSTEM.....	98
变矩器管路系统.....	100
TORQUE CONVERTER PIPING SYSTEM.....	100
变速箱管路系统.....	102
TORQUE TRANSMISSION PIPING SYSYTEM.....	102
变速箱管路系统.....	104
TORQUE TRANSMISSION PIPING SYSYTEM.....	104
变矩器管路系统 (配国 II 发动机) .....	106
TORQUE CONVERTER PIPING SYSTEM (GOING WITH THE NATIONAL II-ENGINE).....	106

变速箱管路系统（配国 II 发动机） .....	108
TORQUE CONVERTER PIPING SYSTEM (GOING WITH THE NATIONAL II-ENGINE).....	108
变速箱管路系统（配国 II 发动机） .....	110
TORQUE CONVERTER PIPING SYSTEM (GOING WITH THE NATIONAL II-ENGINE).....	110
油冷器管路系统（配国 II 发动机） .....	112
OIL COOLER PIPING SYSYTEM (GOING WITH THE NATIONAL II-ENGINE) .....	112
<b>转向系统和终传动.....</b>	<b>115</b>
<b>STEERING SYSTEM AND FINAL DRIVE.....</b>	<b>115</b>
主机架与后桥箱.....	116
MAIN FRAME AND STEERING CASE.....	116
加油管与油尺.....	118
OIL FILTER AND LEVEL GAUGE.....	118
主机架与后桥箱（配国 II 发动机） .....	120
MAIN FRAME AND STEERING CASE (GOING WITH THE NATIONAL II-ENGINE).....	120
加油管与油尺（配国 II 发动机） .....	122
OIL FILTER AND LEVEL GAUGE (GOING WITH THE NATIONAL II-ENGINE) .....	122
<b>锥齿轮与轴.....</b>	<b>124</b>
<b>BEVEL GEAR AND SHAFT.....</b>	<b>124</b>
<b>转向离合器总成.....</b>	<b>126</b>
<b>STEERING CLUTCH ASS'Y.....</b>	<b>126</b>
<b>制动带与联动装置.....</b>	<b>128</b>
<b>BRAKE BAND AND LINKAGE.....</b>	<b>128</b>
<b>制动带与联动装置.....</b>	<b>130</b>
<b>BRAKE BAND AND LINKAGE.....</b>	<b>130</b>
<b>制动助力器.....</b>	<b>132</b>
<b>BRAKE BOOSTER.....</b>	<b>132</b>
<b>转向控制杆.....</b>	<b>134</b>
<b>STEERING CONTROL LEVER.....</b>	<b>134</b>
<b>制动踏板.....</b>	<b>136</b>
<b>BRAKE PEDAL.....</b>	<b>136</b>
<b>制动连杆.....</b>	<b>138</b>
<b>BRAKE LINKAGE.....</b>	<b>138</b>

停车制动.....	140
<b>PARKING BRAKE</b> .....	<b>140</b>
转向油泵.....	142
<b>STEERING PUMP</b> .....	<b>142</b>
粗滤器总成.....	144
<b>COARSE STRAINER ASS'Y</b> .....	<b>144</b>
转向阀.....	146
<b>STEERING VALVE</b> .....	<b>146</b>
转向阀.....	148
<b>STEERING VALVE</b> .....	<b>148</b>
安全阀.....	150
<b>SAFETY VALVE</b> .....	<b>150</b>
制动管路系统.....	152
<b>BRAKE PIPING SYSTEM</b> .....	<b>152</b>
制动管路系统.....	154
<b>BRAKE PIPING SYSTEM</b> .....	<b>154</b>
转向管路系统 (1/2) .....	156
<b>STEERING PIPING SYSTEM (1/2)</b> .....	<b>156</b>
转向管路系统 (1/2) .....	158
<b>STEERING PIPING SYSTEM (1/2)</b> .....	<b>158</b>
转向管路系统 (2/2) .....	160
<b>STEERING PIPING SYSTEM (2/2)</b> .....	<b>160</b>
集中测压管路.....	162
<b>PRESSURE MEASUREMENT PIPING</b> .....	<b>162</b>
平衡梁总成.....	164
<b>EQUALIZER BAR ASS'Y</b> .....	<b>164</b>
终传动箱.....	166
<b>FINAL DRIVE CASE</b> .....	<b>166</b>
终传动箱.....	168
<b>FINAL DRIVE CASE</b> .....	<b>168</b>
终传动齿轮轴与链轮.....	170
<b>FINAL DRIVE GEAR SHAFT AND SPROCKET</b> .....	<b>170</b>
终传动齿轮轴与链轮.....	172
<b>FINAL DRIVE GEAR SHAFT AND SPROCKET</b> .....	<b>172</b>
行走系统.....	<b>175</b>
<b>TRACK SYSTEM</b> .....	<b>175</b>
台车架.....	176

TRACK FRAME ASS'Y.....	176
涨紧装置.....	178
TENSION DEVICE.....	178
涨紧装置.....	180
TENSION DEVICE.....	180
台车架盖.....	182
TRACK FRAME COVER.....	182
支重轮护板.....	184
GUARD PLATE.....	184
引导轮总成.....	186
FRONT IDLER ASS'Y.....	186
支重轮总成.....	188
TRACK ROLLER ASS'Y.....	188
托轮总成.....	190
CARRIER ROLLER ASS'Y.....	190
履带总成.....	192
TRACK ASS'Y.....	192
护罩.....	<b>195</b>
<b>GUARD.....</b>	<b>195</b>
散热器防护装置.....	196
RADIATOR GUARD.....	196
发动机护罩.....	198
ENGINE GUARD.....	198
散热器防护装置（配国 II 发动机）.....	200
RADIATOR GUARD (GOING WITH THE NATIONAL II-ENGINE).....	200
发动机护罩（配国 II 发动机）.....	202
ENGINE GUARD (GOING WITH THE NATIONAL II-ENGINE).....	202
翼板.....	204
FENDER.....	204
支撑架.....	206
SUPPORT.....	206
后盖.....	208
COVER, REAR.....	208
地板架.....	210
FRAME, FLOOR PLATE.....	210
发动机侧护罩.....	212
ENGINE GUARD, SIDE.....	212

底护板总成.....	214
BOTTOM GUARD PLATE ASS'Y.....	214
油缸支撑.....	216
OIL CYLINDER SUPPORT.....	216
油缸支撑 ( 配国 II 发动机 ).....	218
OIL CYLINDER SUPPORT (GOING WITH THE NATIONAL II-ENGINE).....	218
工作装置控制系统.....	<b>221</b>
<b>WORK EQUIPMENT CONTROL SYSTEM.....</b>	<b>221</b>
铲刀升降油缸.....	222
BLADE LIFT CYLINDER.....	222
倾斜油缸.....	224
TILT OIL CYLINDER.....	224
工作油泵总成.....	226
WORK PUMP ASS'Y.....	226
工作油箱 ( 1/2 ) .....	228
HYDRAULIC TANK ( 1/2 ) .....	228
工作油箱 ( 1/2 ) .....	230
HYDRAULIC TANK ( 1/2 ) .....	230
工作油箱 ( 2/2 ) .....	232
HYDRAULIC TANK ( 2/2 ) .....	232
铲刀提升与松土器阀 ( 1/2 ) .....	234
BLADE LIFT AND RIPPER CONTROL VALVE (1/2).....	234
铲刀提升与松土器阀 ( 2/2 ) .....	236
BLADE LIFT AND RIPPER CONTROL VALVE (2/2).....	236
铲刀提升与松土器阀 ( 2/2 ) .....	238
BLADE LIFT AND RIPPER CONTROL VALVE (2/2).....	238
倾斜油缸操纵阀总成.....	240
TILT OIL CYLINDER CONTROL VALVE ASS'Y.....	240
工作泵管路总成.....	242
HYDRAULIC PIPING ASS'Y.....	242
铲刀提升管路 ( 1/2 ) .....	244
BLADE LIFT PIPING ( 1/2 ) .....	244
铲刀提升管路 ( 2/2 ) .....	246
BLADE LIFT PIPING ( 2/2 ) .....	246
铲刀提升油缸.....	248
BLADE LIFT CYLINDER.....	248
快降阀.....	250

QUICK DROP VALVE.....	250
倾斜管路 ( 主机以内 ).....	252
TILT PIPING (WITHIN THE MAIN SYSTEM).....	252
倾斜管路 ( 主机以外 ).....	254
TILT PIPING (OUTSIDE THE MAIN SYSTEM).....	254
倾斜油缸总成.....	256
TILT OIL CYLINDER ASS'Y.....	256
松土器管路.....	258
RIPPER PIPING.....	258
松土器管路.....	260
RIPPER PIPING.....	260
松土器油缸管路.....	262
RIPPER CYLINDER PIPING.....	262
松土器油缸管路.....	264
RIPPER CYLINDER PIPING.....	264
DC 和 PC 阀总成.....	266
DC & PC VALVE ASS'Y.....	266
松土器提升油缸.....	268
RIPPER LIFT CYLINDER.....	268
松土器提升油缸.....	270
RIPPER LIFT CYLINDER.....	270
松土器倾斜油缸.....	272
RIPPER TILT OIL CYLINDER.....	272
松土器倾斜油缸.....	274
RIPPER TILT OIL CYLINDER.....	274
升降操纵伺服阀.....	276
LIFT CONTROL SERVO VALVE.....	276
升降操纵伺服阀.....	278
LIFT CONTROL SERVO VALVE.....	278
倾斜及松土器操纵伺服阀.....	280
TILT AND RIPPER CONTROL SERVO VALVE.....	280
伺服管路总成.....	282
SERVO PIPING ASS'Y.....	282
伺服阀与阀座.....	284
SERVO VALVE AND VALVE SEAT.....	284
铲刀操纵杆.....	286
BLADE CONTROL LEVER.....	286
铲刀操纵联动机构.....	288

BLADE CONTROL LINKAGE.....	288
铲刀倾斜与松土器操纵联动机构.....	290
BLADE TILT AND RIPPER CONTROL LINKAGE.....	290
松土器操纵杆 (1/2).....	292
RIPPER CONTROL LEVER (1/2).....	292
松土器操纵杆 (2/2).....	294
RIPPER CONTROL LEVER (2/2).....	294
工作装置.....	<b>297</b>
<b>WORK EQUIPMENT.....</b>	<b>297</b>
直倾铲.....	298
STRAIGHT TILT BLADE.....	298
直倾铲推杆.....	300
STRAIGHT TILT FRAME.....	300
角铲.....	302
ANGLE BLADE.....	302
弓形架.....	304
C-FRAME.....	304
半 U 形铲.....	306
SEMI-U BLADE.....	306
半 U 形铲推杆.....	308
SEMI-U BLADE FRAME.....	308
半 U 形铲推杆.....	310
SEMI-U BLADE FRAME.....	310
牵引装置.....	312
TRACTION DEVICE.....	312
三齿松土器总成.....	314
TRIPLE-SHANK RIPPLER ASS'Y.....	314
单齿松土器总成.....	316
SINGLE-SHANK RIPPER ASS'Y.....	316
电气系统（不装 GPS）.....	<b>319</b>
<b>ELECTRICAL SYSTEM (WITHOUT GPS).....</b>	<b>319</b>
电气系统 (1/2).....	320
ELECTRICAL SYSTEM (1/2).....	320
电气系统 (2/2).....	322
ELECTRICAL SYSTEM (2/2).....	322
仪表箱.....	324
METER BOX.....	324

继电器与保险丝盒.....	326
RELAY AND FUSE BOX.....	326
蓄电池与继电器.....	328
BATTERY AND RELAY.....	328
驾驶室电气.....	330
CAB ELECTRIC.....	330
电气系统（装 <b>GPS</b> ）.....	<b>333</b>
<b>ELECTRICAL SYSTEM (WITH GPS).....</b>	<b>333</b>
电气系统 (1/2).....	334
ELECTRICAL SYSTEM (1/2).....	334
电气系统 (2/2).....	336
ELECTRICAL SYSTEM (2/2).....	336
仪表箱.....	338
METER BOX.....	338
继电器与保险盒.....	340
RELAY AND FUSE BOX.....	340
蓄电池与继电器.....	342
BATTERY AND RELAY.....	342
附属装置.....	<b>345</b>
<b>OPERATOR COMPARTMENT.....</b>	<b>345</b>
座椅及安装.....	346
OPERATOR'S SEAT.....	346
防翻滚架.....	348
FRAME, ROPS.....	348
驾驶室.....	350
CAB.....	350
驾驶室.....	352
CAB.....	352
标牌涂装及运输图.....	354
MARKS AND PLATES.....	354
集中润滑及履带自动涨紧系统.....	356
LUBRICATING AND TRACK RECOIL SYSTEM.....	356
集中润滑及履带自动涨紧系统.....	358
LUBRICATING AND TRACK RECOIL SYSTEM.....	358

A series of horizontal dashed lines for writing notes.

发动机关联部件

**ENGINE RELATED PARTS**

# 发动机安装 ENGINE MOUNTING

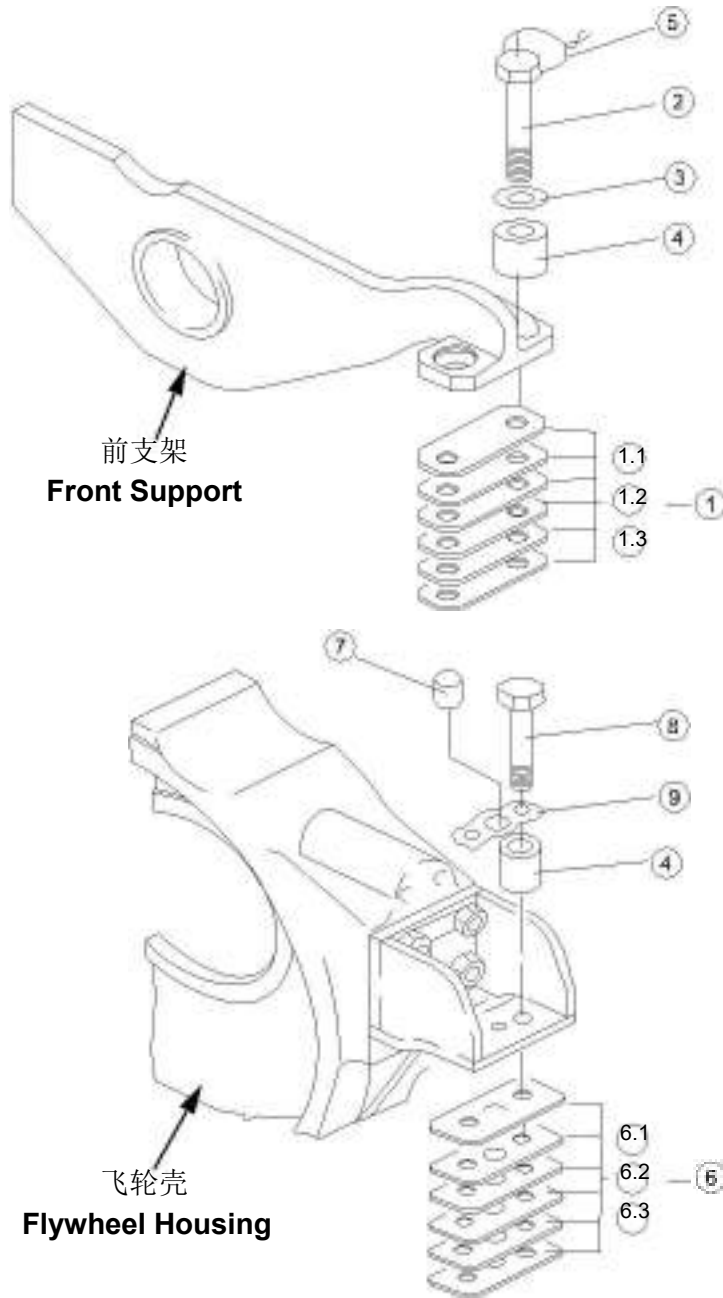

零件图册 | 发动机关联部件

序号 NO.	部件号 PART NO.	零件名称 PART NAME	数量 Q'TY	适用机型 MODEL
1	175-01-00073	垫片总成 Shim ass'y	2	
1.1	175-01-22150	垫片 Shim	6	
1.2	175-01-22160	垫片 Shim	2	
1.3	175-01-22170	垫片 Shim	4	
2	195-01-11240	螺栓 Bolt	4	
3	01643-32260	垫圈 22 Washer 22	4	
4	195-01-11190	衬垫 Gasket	8	
5	195-01-15670	铁丝 Iron wire	2	
6	175-01-00082	垫片总成 Shim ass'y	2	
6.1	175-01-21141	垫片 Shim	6	
6.2	175-01-21151	垫片 Shim	2	
6.3	175-01-21161	垫片 Shim	4	
7	198-01-11140	销 Pin	2	
8	01011-52230	螺栓 M22*130 Bolt M22*130	4	
9	175-01-21173	止动垫片 Stop washer	2	

# 分动箱 TRANSFER CASE

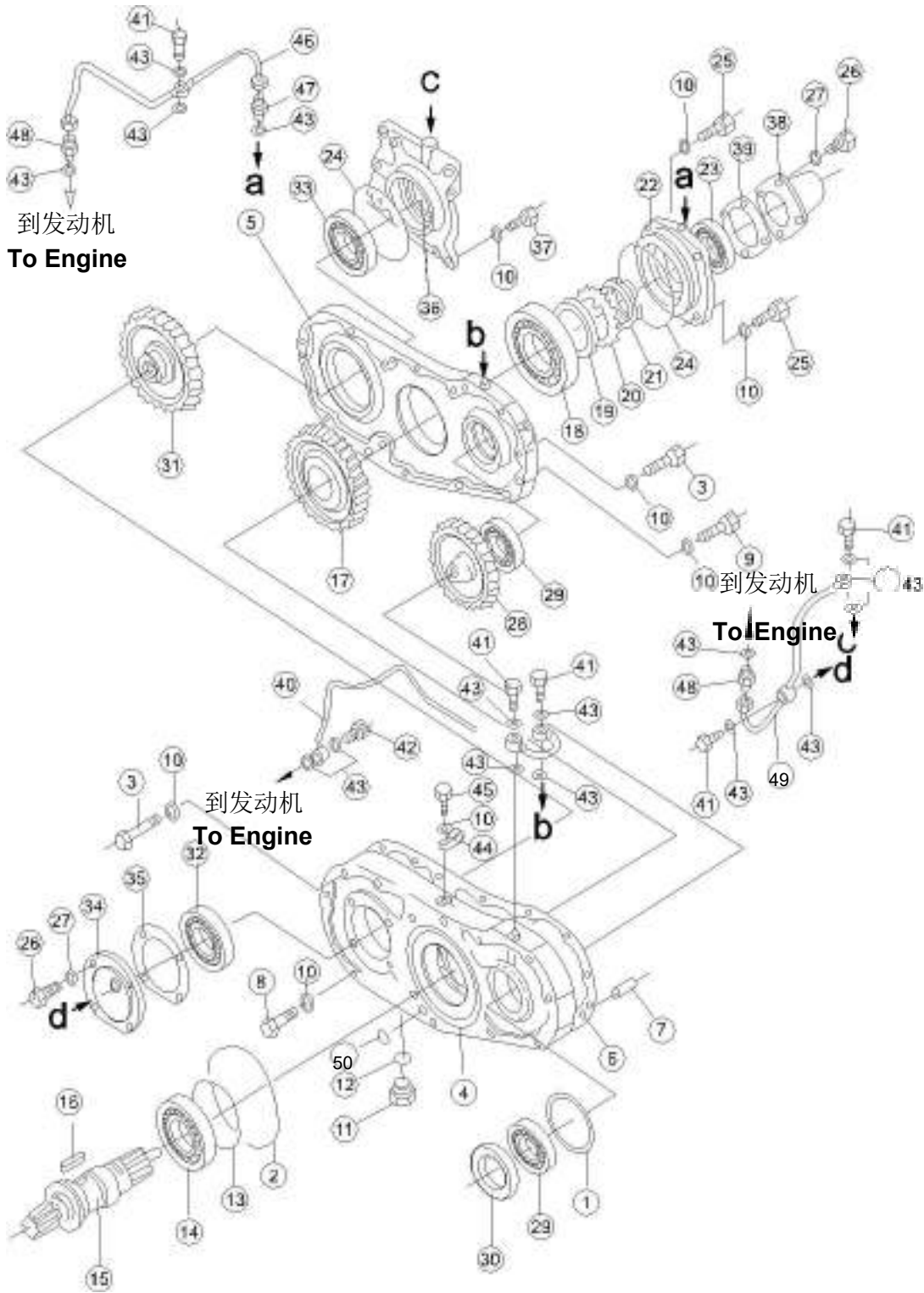

零件图册 | 发动机关联部件

序号 NO.	部件号 PART NO.	零件名称 PART NAME		数量 Q'TY	适用机型 MODEL
1	07000-02105	O 形圈	O-ring	1	
2	07000-05195	O 形圈	O-ring	1	
3	01011-51205	螺栓 M12*105	Bolt M12*105	13	
4	154-01-12111	齿轮箱	Gearbox	1	
5	175-38-11110	分动箱体	Transfer case body	1	
6	154-01-12130	填密垫	Gasket	1	
7	04020-01024	圆柱销	Cylindrical pin	2	
8	01010-51275	螺栓 M12*75	Bolt M12*75	2	
9	01010-51250	螺栓 M12*50	Bolt M12*50	2	
10	01602-21236	垫圈 12	Washer 12	24	
11	07044-12412	螺塞	Screw plug	1	
12	07002-02434	O 形圈	O-ring	1	
13	150-21-22180	开口环	Ring, Cotter	1	
14	154-01-12280	滚柱轴承	Roller bearing	1	
15	154-01-12221	轴	Shaft	1	
16	04000-02050	平键	Flat key	2	
17	154-01-12230	齿轮	Gear	1	
18	GB276-6314C4	深沟球轴承	Deep groove ball bearings	1	
19	154-01-12240	套环	Collar	1	
20	01658-16823	锁紧垫圈	Lock washer	1	
21	01530-06814	螺母 M68*2	Nut M68*2	1	
22	154-01-12250	盖	Cover	1	
23	07012-00060	骨架油封	Oil seal	1	
24	07000-05150	O 形圈	O-ring	2	
25	01010-51230	螺栓 M12*30	Bolt M12*30	4	
26	01010-51025	螺栓 M10*25	Bolt M10*25	8	
27	01602-21030	垫圈 10	Washer 10	8	
28	154-01-12310	齿轮	Gear	1	
29	GB276-6209C4	深沟球轴承	Deep groove ball bearings	2	
30	154-01-12320	环	Ring	1	
31	175-38-11120	齿轮	Gear	1	
32	GB276-6212C4	深沟球轴承	Deep groove ball bearings	1	
33	GB276-6312C4	深沟球轴承	Deep groove ball bearings	1	
34	154-01-12420	盖	Cover	1	
35	154-01-12430	填密垫	Gasket	1	
36	175-38-11130	壳	Housing	1	
37	01010-51255	螺栓 M12*55	Bolt M12*55	2	

# 分动箱 TRANSFER CASE

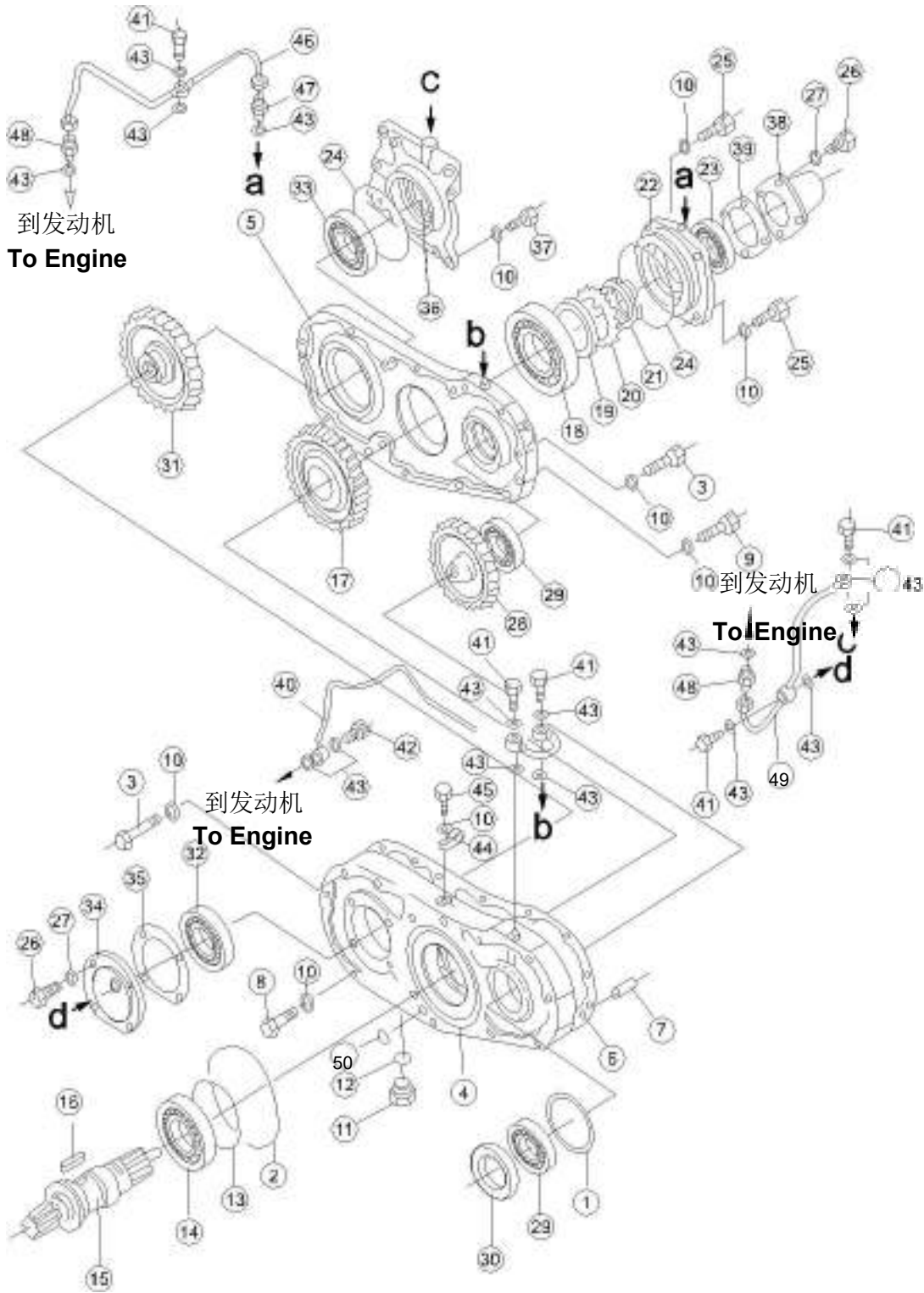

零件图册 | 发动机关联部件

序号 NO.	部件号 PART NO.	零件名称 PART NAME	数量 Q'TY	适用机型 MODEL
38	154-01-12260	盖 Cover	1	
39	154-01-12270	填密垫 Gasket	1	
40	154-01-12530	管 Tube	1	
41	6600-01-3860	螺栓管接头 Nipple	5	
42	07206-10610	接头 Nipple	1	
43	07005-01012	密封垫圈 Sealing gasket	15	
44	08036-10614	线夹 Wire clip	1	
45	01010-51220	螺栓 M12*20 Bolt M12*20	1	
46	154-01-12541	螺栓管接头 Nipple	1	
47	154-01-12520	管接头 Nipple	1	
48	07211-80610	接头 Nipple	2	
49	154-01-12552	管 Tube	1	
50	07000-13030	O 形圈 O-ring	1	

# 飞轮壳总成 FLYWHEEL HOUSING ASS'Y

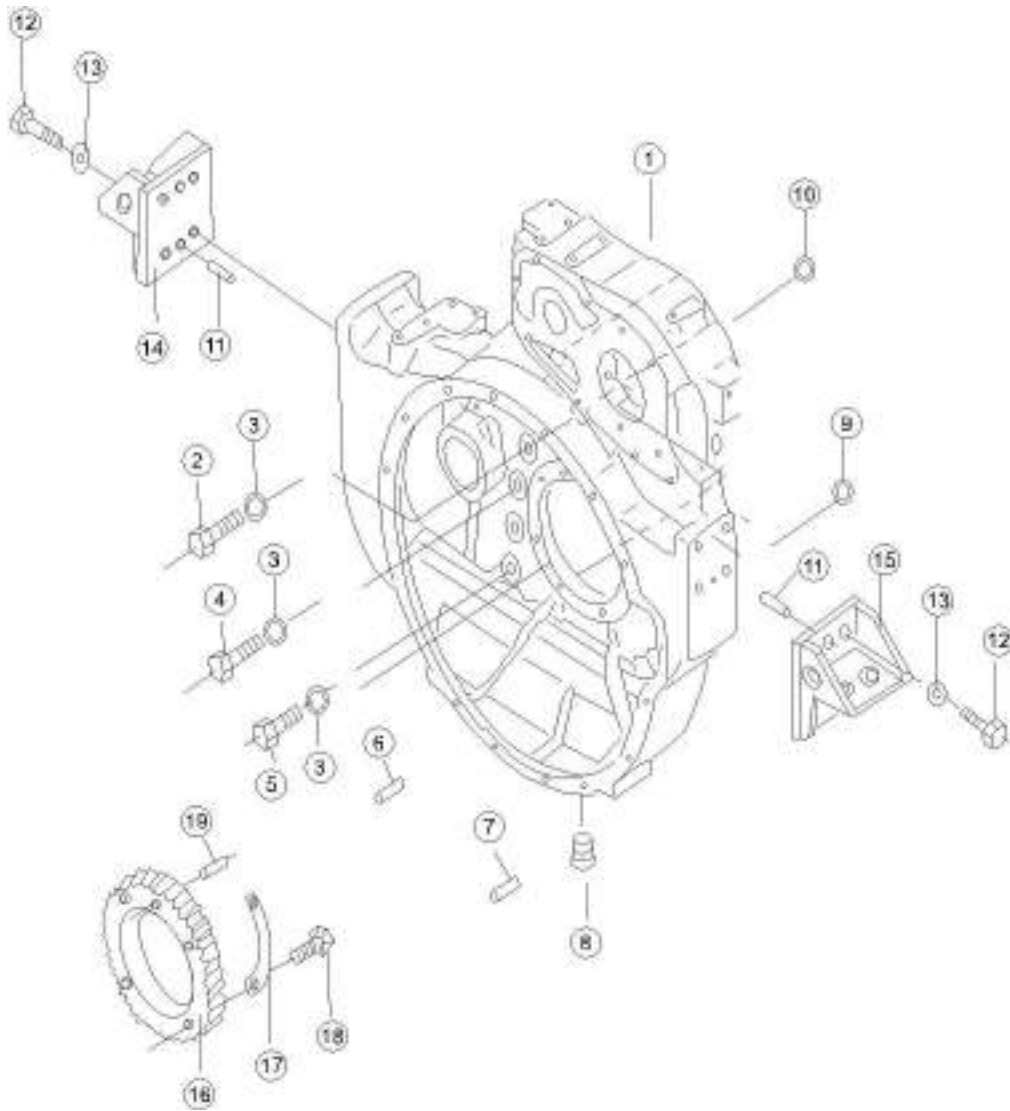

零件图册 | 发动机关联部件

序号 NO.	部件号 PART NO.	零件名称 PART NAME	数量 Q'TY	适用机型 MODEL
0	6710-23-4000	动力输出箱总成 Power output box ass'y	1	
1	6710-23-4110	飞轮罩壳 Flywheel housing	1	
2	6710-23-4120	螺栓 Bolt	2	
3	6600-01-2740	弹簧垫圈 Spring washer	9	
4	6710-23-4130	螺栓 Bolt	5	
5	6710-23-4140	螺栓 Bolt	2	
6	6711-21-C010-01	圆柱销 Cylindrical pin	1	
7	6711-21-C010-02	圆柱销 Cylindrical pin	1	
8	07042-20415	螺塞 Screw plug	1	
9	07046-12016	皿形塞 Plug	4	
10	07046-15520	皿形塞 Plug	1	
11	04020-01434	圆柱销 Cylindrical pin	4	
12	01010-51860	螺栓 M18*60 Bolt M18*60	8	
13	6710-23-4730	衬垫 Gasket	8	
14	6710-23-4720	后托架 ( 左 ) Rear bracket (L.H.)	1	
15	6710-23-4710	后托架 ( 右 ) Rear bracket (R.H.)	1	
16	6623-31-1371	传动泵齿轮 Gear, Drive pump	1	
17	6623-31-1380	锁垫 Lock washer	2	
18	01010-31255	螺栓 Bolt	4	
19	6623-31-1390	定位销 Pin, Dowel	1	

# 出力装置 POWER TAKE OFF

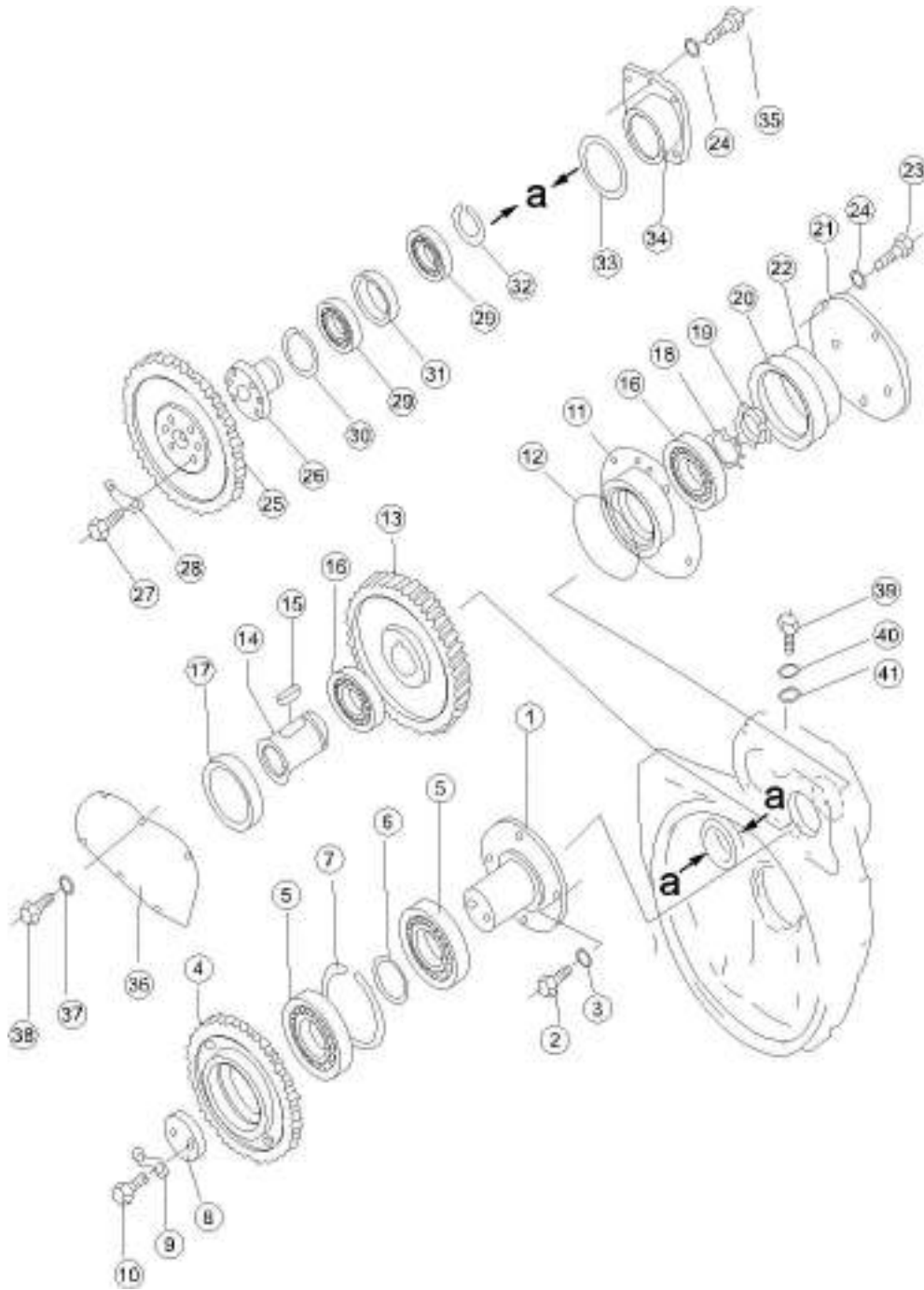

零件图册 | 发动机关联部件

序号 NO.	部件号 PART NO.	零件名称 PART NAME	数量 Q'TY	适用机型 MODEL
0	6710-23-4000	动力输出箱总成 Power output box ass'y	1	
1	6691-21-4310	惰轮轴 Idler shaft	1	
2	01010-51435	螺栓 M14*35 Bolt M14*35	4	
3	01602-21442	垫圈 14 Washer 14	4	
4	6691-21-4321	惰轮 Idler	1	
5	GB276-6010	深沟球轴承 Deep groove ball bearings	2	
6	6623-21-4330	衬套 Bushing	1	
7	6623-21-4350	开口环 Ring, Cotter	1	
8	6623-21-4340	垫板 Plate	1	
9	6623-21-4360	锁板 Lock plate	1	
10	01050-51230	螺栓 M12*1.5*30 Bolt M12*1.5*30	2	
11	6691-21-4120	轴承罩 Bearing cover	1	
12	07000-13145	O 形圈 O-ring	1	
13	6691-21-4160	泵传动齿轮 Drive gear, Pump	1	
14	6691-21-4170	泵传动轴 Drive shaft, Pump	1	
15	04000-01850	平键 Flat key	1	
16	GB276-6214	深沟球轴承 Deep groove ball bearings	2	
17	6691-21-4190	定位环 Ring, Locating	1	
18	01658-26823	垫圈 Washer	1	
19	01530-06814	螺母 M68*2 Nut M68*2	1	
20	6691-21-4130	衬套 Bushing	1	
21	6691-21-4140	盖 Cover	1	
22	07000-13140	O 形圈 O-ring	1	
23	01010-51035	螺栓 M10*35 Bolt M10*35	5	
24	01602-21030	垫圈 10 Washer 10	9	
25	6710-23-4520	泵传动齿轮 Drive gear, Pump	1	
26	6710-23-4510	轴 Shaft	1	
27	01050-51020	螺栓 M10*1.25*20 Bolt M10*1.25*20	4	
28	6645-22-4550	锁板 Lock plate	2	
29	GB276-6310C3	深沟球轴承 Deep groove ball bearings	2	
30	04065-18025	弹性垫圈 Washer	1	
31	6128-21-4540	隔圈 Spacer ring	1	
32	04064-15020	弹簧挡圈 Spring ring	1	
33	07000-13100	O 形圈 O-ring	1	
34	6710-23-4410	轴承壳 Bearing casing	1	
35	01010-51045	螺栓 M10*45 Bolt M10*45	4	
36	6691-21-4910	盖 Cover	1	

# 出力装置 POWER TAKE OFF

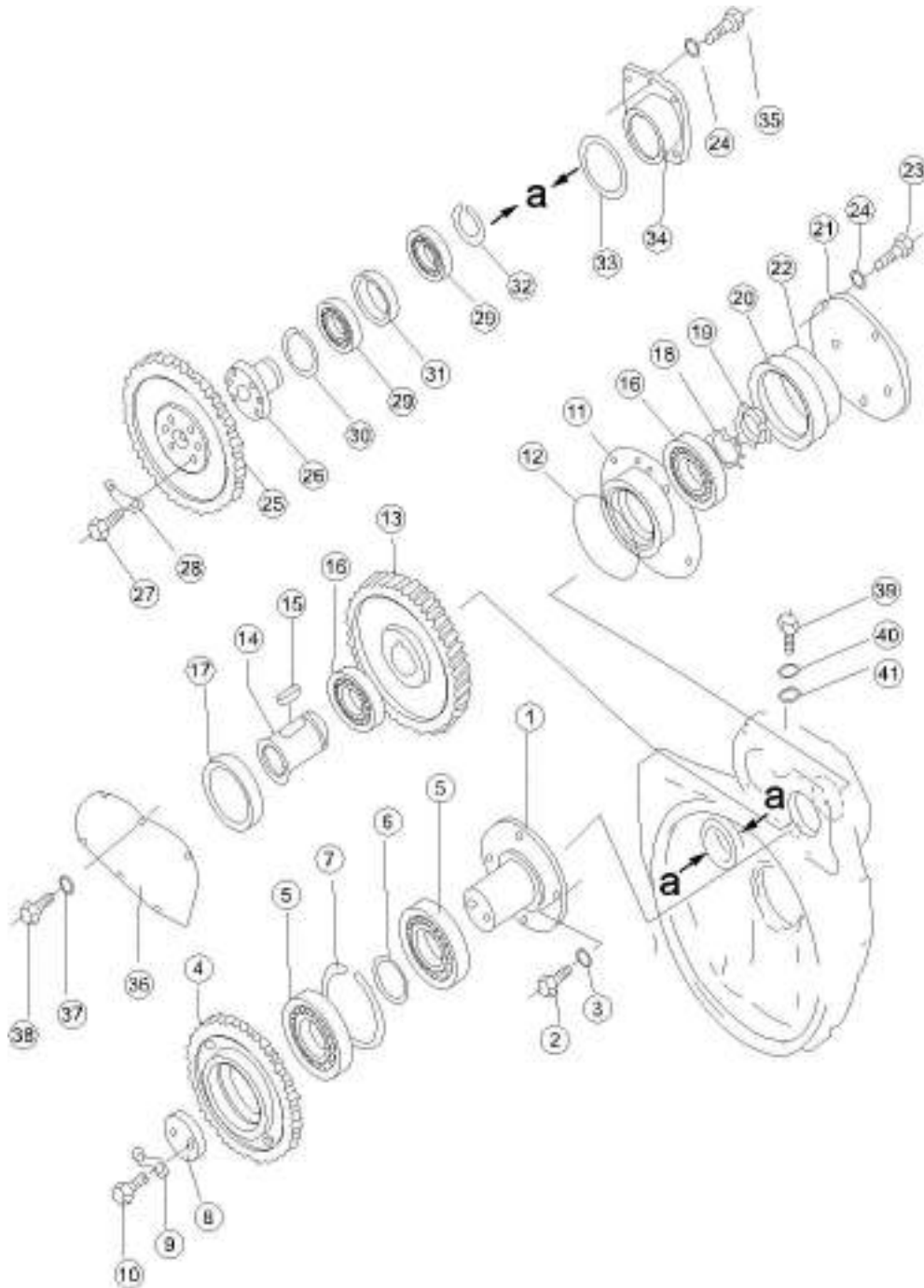

零件图册 | 发动机关联部件

序号 NO.	部件号 PART NO.	零件名称 PART NAME	数量 Q'TY	适用机型 MODEL
38	01010-51230	螺栓 M12*30      Bolt M12*30	6	
39	01010-51645	螺栓 M16*45      Bolt M16*45	1	
40	01602-21648	垫圈 16            Washer 16	1	
41	01643-31645	垫圈 16            Washer 16	1	

### 出力装置润滑管 PTO LUBRICATING OIL PIPING

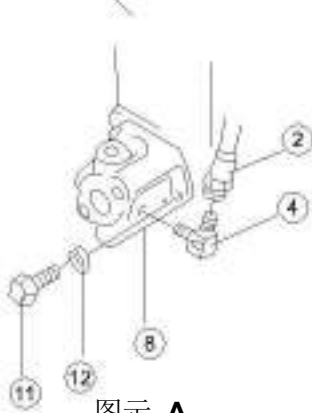
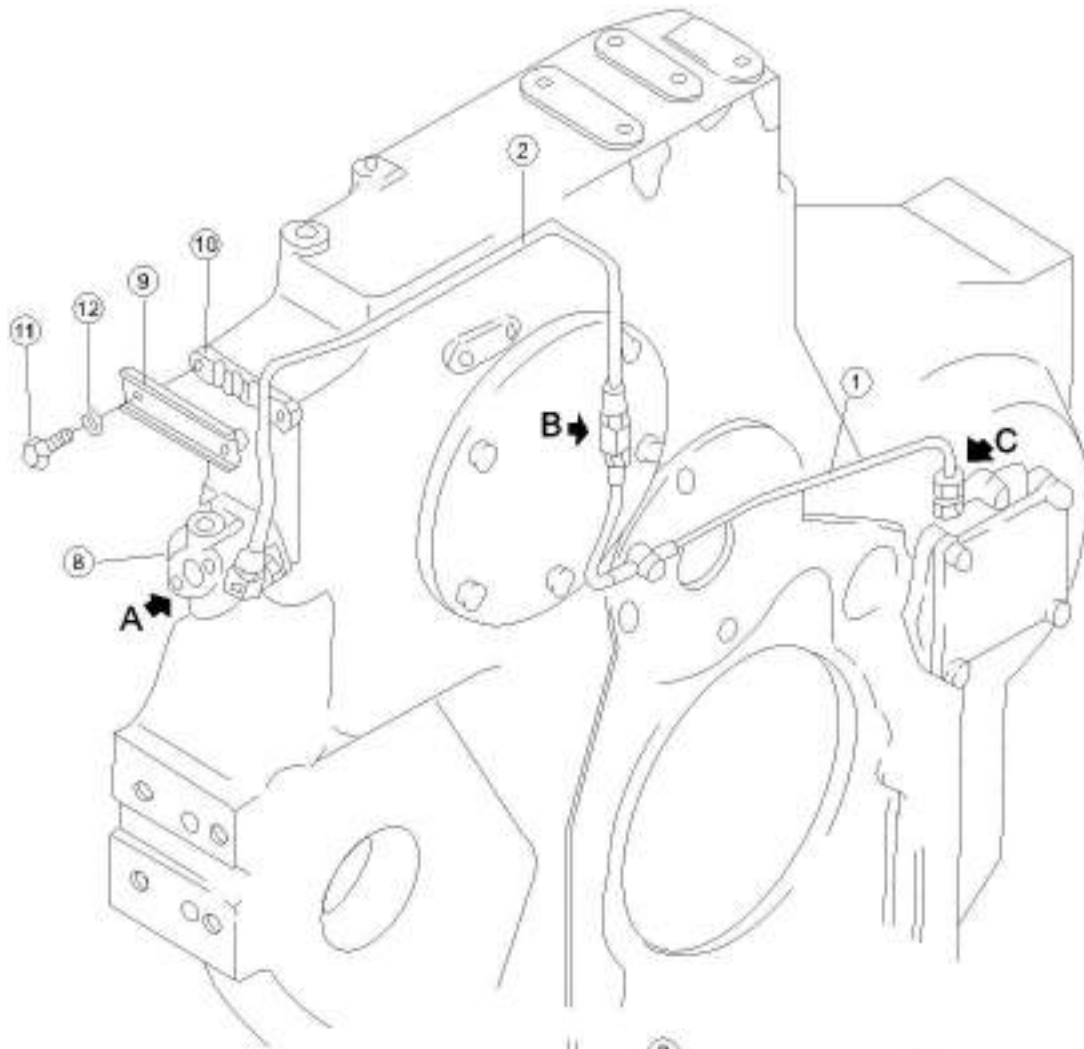

图示 A  
Detail A

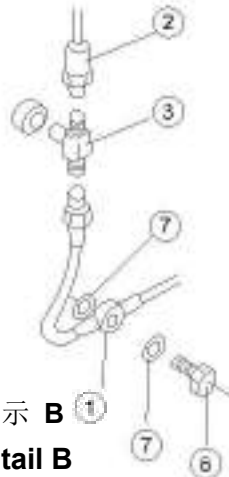

图示 B  
Detail B

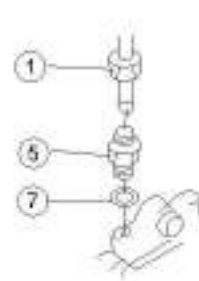

图示 C  
Detail C

零件图册 | 发动机关联部件

序号 NO.	部件号 PART NO.	零件名称 PART NAME		数量 Q'TY	适用机型 MODEL
0	6710-23-4000	动力输出箱总成	Power output box ass'y	1	
1	6710-53-9510	管组件	Tube ass'y	1	
2	6691-51-9521	管	Tube	1	
3	6691-51-9570	T 型管接头	T-Joint	1	
4	07206-30710	铰接螺栓	Bolt, Hinge	1	
5	6691-51-9580	连接器	Connector	1	
6	6600-01-3860	螺栓管接头	Nipple	1	
7	07003-01015	密封垫圈	Sealing gasket	3	
8	6691-51-9560	分配器	Distributor	1	
9	6600-01-5930	夹板 A	Plate A	1	
10	6691-51-9540	夹板 B	Plate B	1	
11	01010-51030	螺栓 M10*30	Bolt M10*30	4	
12	01602-01030	垫圈	Washer	4	

前支架  
**FRONT BRACKET**



零件图册 | 发动机关联部件

序号 NO.	部件号 PART NO.	零件名称 PART NAME	数量 Q'TY	适用机型 MODEL
1	6710-23-3710	前支架 Front bracket	1	

### 排气管与消声器 EXHAUST PIPE AND MUFFLER

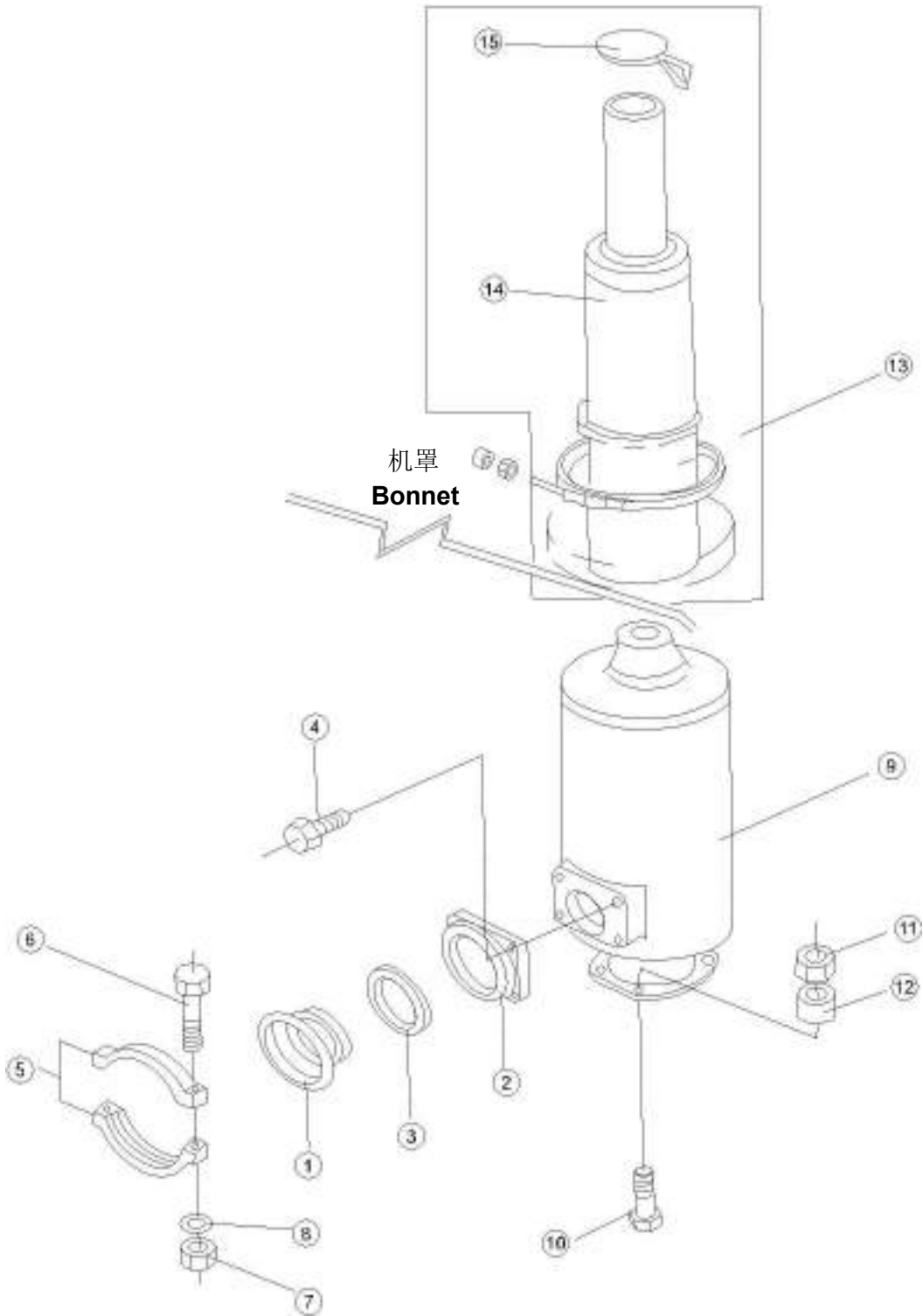

零件图册 | 发动机关联部件

序号 NO.	部件号 PART NO.	零件名称 PART NAME		数量 Q'TY	适用机型 MODEL
1	6631-11-5820	管接头	Nipple	1	
2	6693-12-5530	凸缘	Flange	1	
3	6112-13-5250	密封环	Sealing ring	1	
4	6128-11-5760	螺栓	Bolt	4	
5	6657-11-5590	箍带	Band, Clamp	2	
6	01010-50870	螺栓 M8*70	Bolt M8*70	2	
7	01580-00806	螺母 M8	Nut M8	2	
8	01602-20825	垫圈 8	Washer 8	2	
9	6710-13-5710	消音器	Muffler	1	
10	01050-51265	螺栓 M12*1.5*65	Bolt M12*1.5*65	4	
11	01582-01210	螺母 M12*1.5	Nut M12*1.5	4	
12	6678-51-9520	衬垫	Gasket	4	
13	6502-12-1722	V 形联结器	V-coupling	1	
14	6710-13-5730	排气管	Exhaust pipe	1	
15	6710-13-5780	罩盖	Cover	1	

# 空气滤清器与罩 AIR CLEANER AND CAP

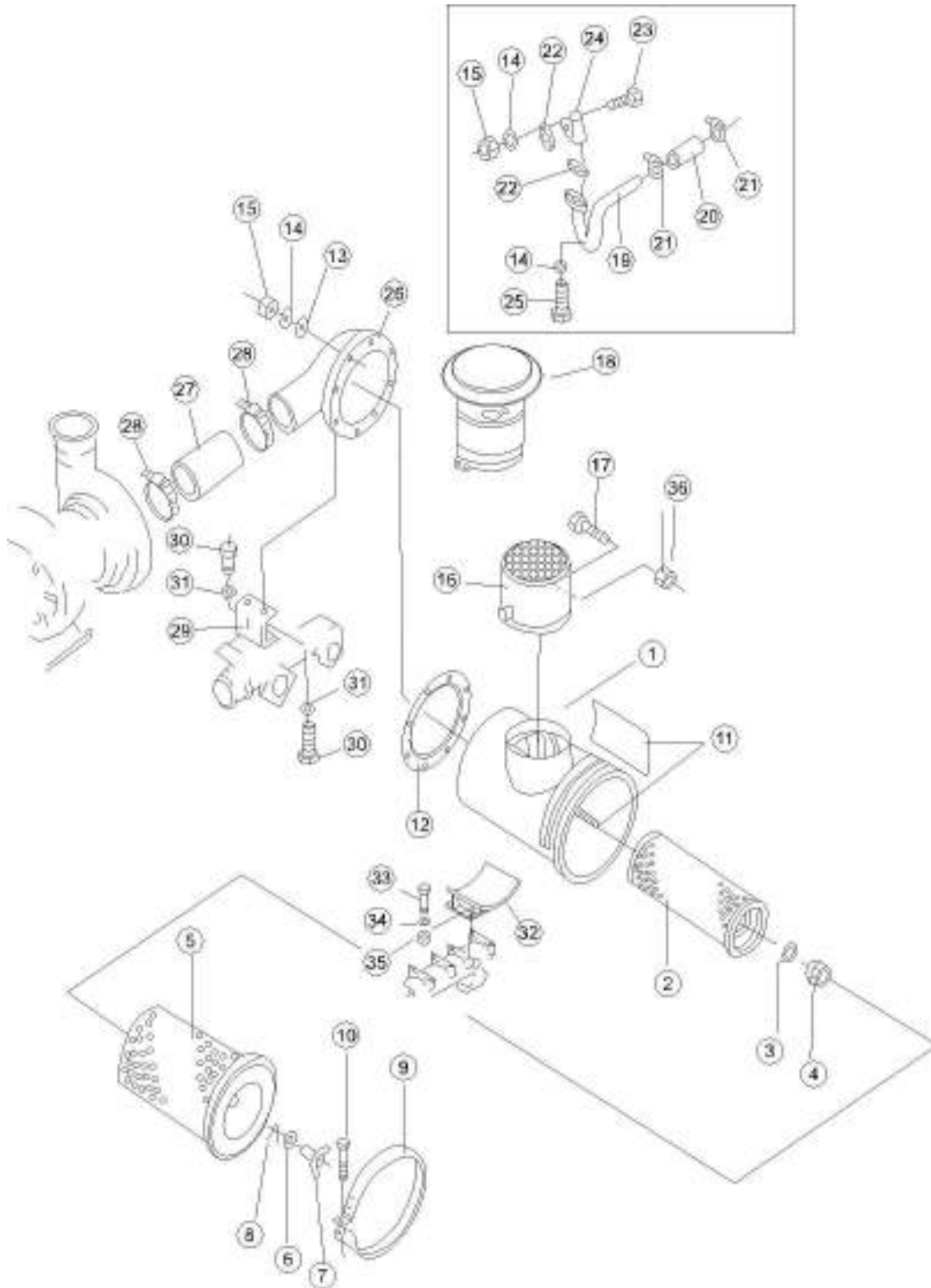

零件图册 | 发动机关联部件

序号 NO.	部件号 PART NO.	零件名称 PART NAME	数量 Q'TY	适用机型 MODEL
0	6127-82-7106	空滤器总成 Air filter ass'y	1	
1	6127-82-7115	空滤器主体 Air filter body	1	
2	6127-81-7412	内芯元件 Inner core element	1	
3	600-181-7511	密封圈 Seal ring	1	
4	600-181-4370	螺母 Nut	1	
5	6128-81-7320	外芯元件 Outer core element	1	
6	600-181-4440	密封垫卷 Washer	1	
7	600-181-4420	蝶形螺母 Butterfly-shaped nut	1	
8	600-181-4430	夹 Clip	1	
9	6127-11-4360	箍带 Band, Clamp	1	
10	6643-11-4641	螺栓 Bolt	1	
11	09637-00160	警告牌 Warning Sign	1	
12	6127-81-4821	密封垫 Gasket	1	
13	01640-21016	垫圈 10 Washer 10	8	
14	01602-21030	垫圈 10 Washer 10	12	
15	01580-01008	螺母 Nut	10	
16	6090-01-4250	粗滤器总成 Coarse strainer ass'y	1	
17	01016-51045	螺栓 M10*45 Bolt M10*45	1	
18	600-181-4950	罩 Cover	1	
19	6710-13-4770	排气口管子 Tube	1	
20	6127-11-5960	软管 Hose	1	
21	07281-00489	喉箍 Hose Clamp	2	
22	6128-11-5610	密封垫 Gasket	2	
23	01010-51035	螺栓 M10*35 Bolt M10*35	2	
24	6128-11-5302	止回阀 Check Valve	1	
25	01010-51050	螺栓 M10*50 Bolt M10*50	2	
26	6710-13-4210	连接管 Connecting pipe	1	
27	6693-12-4360	软管 Hose	1	
28	07281-01589	喉箍 Hose Clamp	2	
29	6711-11-4530	空气连接器托架 Bracket, Connector	1	
30	01010-51230	螺栓 M12*30 Bolt M12*30	4	
31	01602-21236	垫圈 12 Washer 12	4	
32	6710-13-4510	托座 Seat	1	
33	02011-70552	螺栓 Bolt	4	
34	02310-11020	垫圈 Washer	4	
35	01642-20810	垫圈 8 Washer 8	4	
36	01580-11008	螺母 M10 Nut M10	1	

排气管与消声器（配国 II 发动机）  
**EXHAUST PIPE AND MUFFLER**  
**(GOING WITH THE NATIONAL II-ENGINE)**

此组件用于康明斯国 II  
**NTAA855-C360S20** 型发动机  
This assembly is used for Cummins  
National II- **NTAA855-C360S20** engine

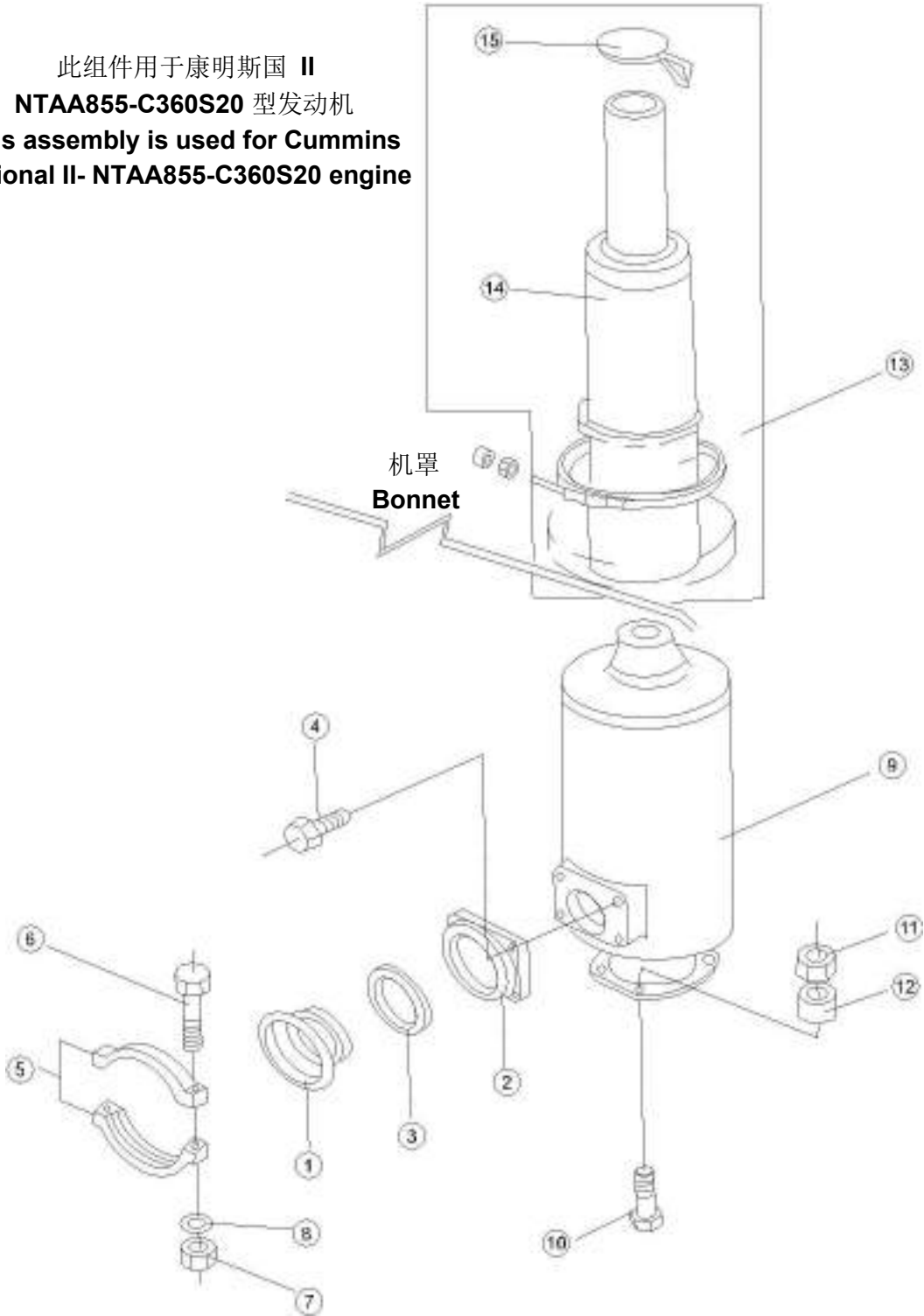

零件图册 | 发动机关联部件

序号 NO.	部件号 PART NO.	零件名称 PART NAME		数量 Q'TY	适用机型 MODEL
1	6631-11-5820	管接头	Nipple	1	
2	6693-12-5530	凸缘	Flange	1	
3	6112-13-5250	密封环	Sealing ring	1	
4	6128-11-5760	螺栓	Bolt	4	
5	6657-11-5590	箍带	Band, Clamp	2	
6	01010-50870	螺栓 M8*70	Bolt M8*70	2	
7	01580-00806	螺母 M8	Nut M8	2	
8	01602-20825	垫圈 8	Washer 8	2	
9	6710-13-5710	消音器	Muffler	1	
10	01050-51265	螺栓 M12*1.5*65	Bolt M12*1.5*65	4	
11	01582-01210	螺母 M12*1.5	Nut M12*1.5	4	
12	6678-51-9520	衬垫	Gasket	4	
13	6502-12-1722	V 形联结器	V-coupling	1	
14	6710-13-5730	排气管	Exhaust pipe	1	
15	6710-13-5780	罩盖	Cover	1	

# 空气滤清器与罩 (配国 II 发动机) AIR CLEANER AND CAP (GOING WITH THE NATIONAL II-ENGINE)

此组件用于康明斯国 II  
NTAA855-C360S20 型发动机  
This assembly is used for Cummins  
National II- NTAA855-C360S20 engine

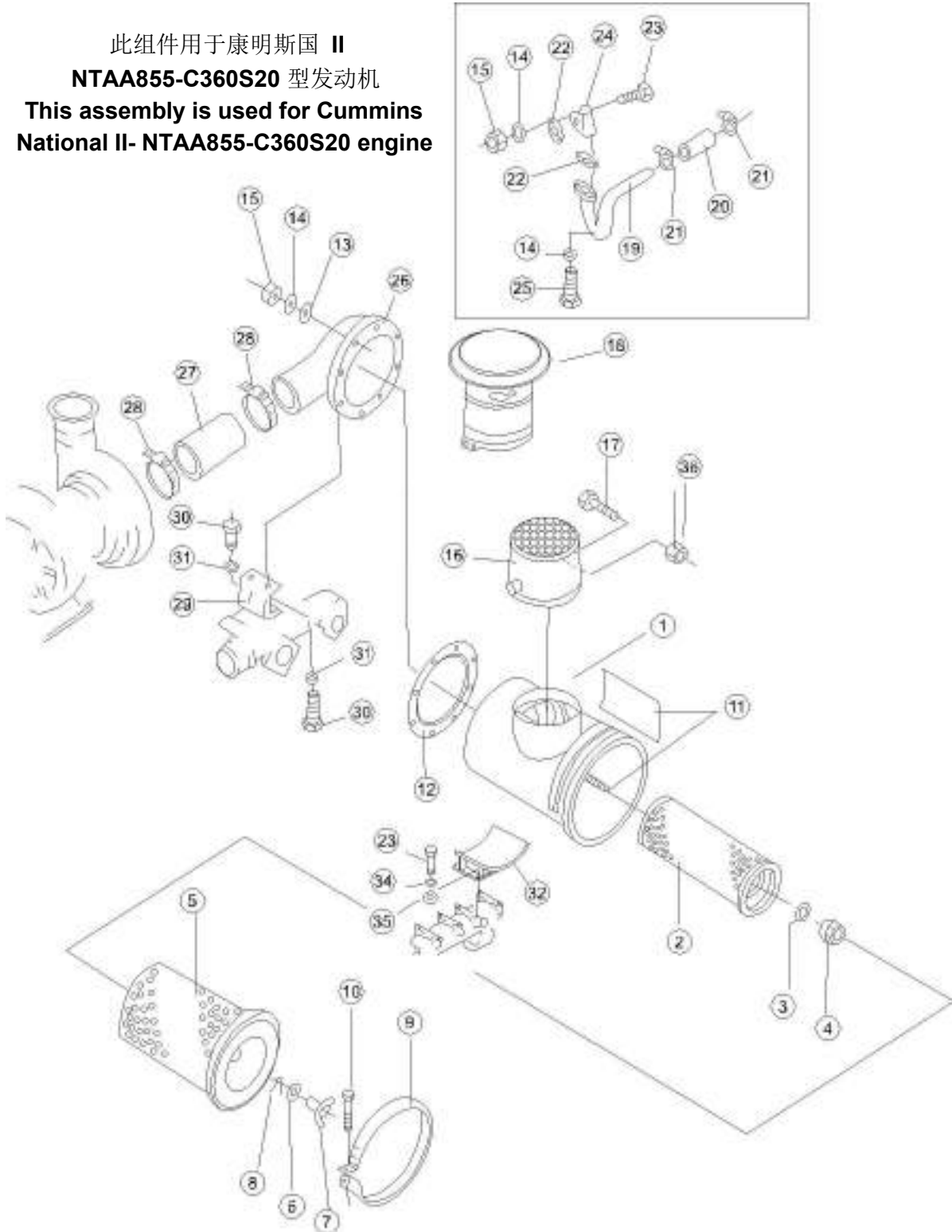

零件图册 | 发动机关联部件

序号 NO.	部件号 PART NO.	零件名称 PART NAME	数量 Q'TY	适用机型 MODEL
0	6127-82-7106	空滤器总成 Air filter ass'y	1	
1	6127-82-7115	空滤器主体 Air filter body	1	
2	6127-81-7412	内芯元件 Inner core element	1	
3	600-181-7511	密封圈 Seal ring	1	
4	600-181-4370	螺母 Nut	1	
5	6128-81-7320	外芯元件 Outer core element	1	
6	600-181-4440	密封垫卷 Washer	1	
7	600-181-4420	蝶形螺母 Butterfly-shaped nut	1	
8	600-181-4430	夹 Clip	1	
9	6127-11-4360	箍带 Band, Clamp	1	
10	6643-11-4641	螺栓 Bolt	1	
11	09637-00160	警告牌 Warning Sign	1	
12	6127-81-4821	密封垫 Gasket	1	
13	01640-21016	垫圈 10 Washer 10	8	
14	01602-21030	垫圈 10 Washer 10	12	
15	01580-01008	螺母 Nut	10	
16	6090-01-4250	粗滤器总成 Coarse strainer ass'y	1	
17	01016-51045	螺栓 M10*45 Bolt M10*45	1	
18	600-181-4950	罩 Cover	1	
19	6710-13-4770	排气口管子 Tube	1	
20	6127-11-5960	软管 Hose	1	
21	07281-00489	喉箍 Hose Clamp	2	
22	6128-11-5610	密封垫 Gasket	2	
23	01010-51035	螺栓 M10*35 Bolt M10*35	2	
24	6128-11-5302	止回阀 Check Valve	1	
25	01010-51050	螺栓 M10*50 Bolt M10*50	2	
26	6710-13-4210	连接管 Connecting pipe	1	
27	6693-12-4360	软管 Hose	1	
28	07281-01589	喉箍 Hose Clamp	2	
29	6711-11-4530	空气连接器托架 Bracket, Connector	1	
30	01010-51230	螺栓 M12*30 Bolt M12*30	4	
31	01602-21236	垫圈 12 Washer 12	4	
32	171-01A-01100	托座 Seat	1	
33	01010-50830	螺栓 M8*30 Bolt M8*30	4	
34	02310-11020	垫圈 Washer	4	
35	01642-20810	垫圈 8 Washer 8	4	
36	01580-11008	螺母 M10 Nut M10	1	

# 燃油操纵杆 FUEL CONTROL LEVER

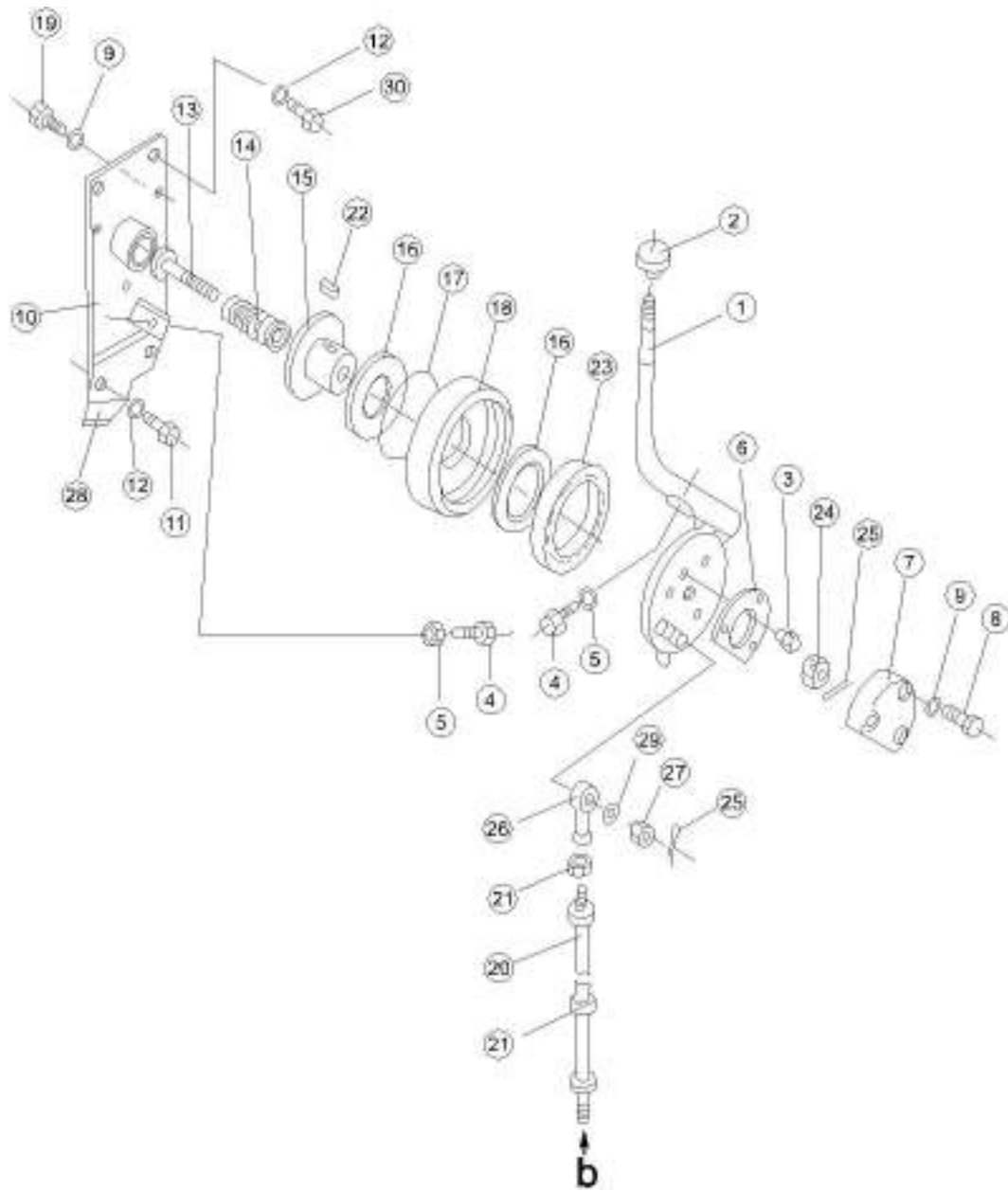

零件图册 | 发动机关联部件

序号 NO.	部件号 PART NO.	零件名称 PART NAME		数量 Q'TY	适用机型 MODEL
1	175-43-42372	摇臂	Rock arm	1	
2	09304-01250	手柄	Handle	1	
3	07042-20108	螺塞	Screw plug	1	
4	01016-50860	螺栓 M8*60	Bolt M8*60	2	
5	01580-10806	螺母 M8	Nut M8	2	
6	175-43-41542	垫圈	Washer	1	
7	175-43-42351	盖	Cover	1	
8	01010-50630	螺栓 M6*30	Bole M6*30	3	
9	01602-20619	垫圈 6	Washer 6	6	
10	175-43-C1181	支架	Bracket	1	
11	01010-51225	螺栓 M12*25	Bolt M12*25	2	
12	01643-31232	垫圈 12	Washer 12	4	
13	175-43-34160	螺栓	Bolt	1	
14	178-43-13130	弹簧	Spring	1	
15	131-43-28130	套	Sleeve	1	
16	110-43-15171	石棉板	Asbestos plate	2	
17	07000-12085	O 形圈	O-ring	1	
18	175-43-34130	壳体	Housing body	1	
19	01010-50616	螺栓 M6*16	Bolt M6*16	3	
20	175-43-24670	软轴	Flexible shaft	1	
21	175-54-33470	锥形防尘木塞	Cone dust plug	1	
22	04000-10512	平键	Flat key	1	
23	07012-00075	骨架油封	Oil seal	1	
24	01592-11012	螺母 M10*1.25	Nut M10*1.25	1	
25	04050-12018	开口销	Cotter pin	2	
26	195-43-25170	关节轴承	Joint bearing	1	
27	01593-31008	螺母 M10*1.25	Nut M10*1.25	1	
28	175-43-42660	支架	Bracket	1	
29	04254-11032	垫圈	Washer	1	
30	01010-51235	螺栓 M12*35	Bolt M12*35	2	

### 燃油操纵连杆机构 FUEL CONTROL LINKAGE

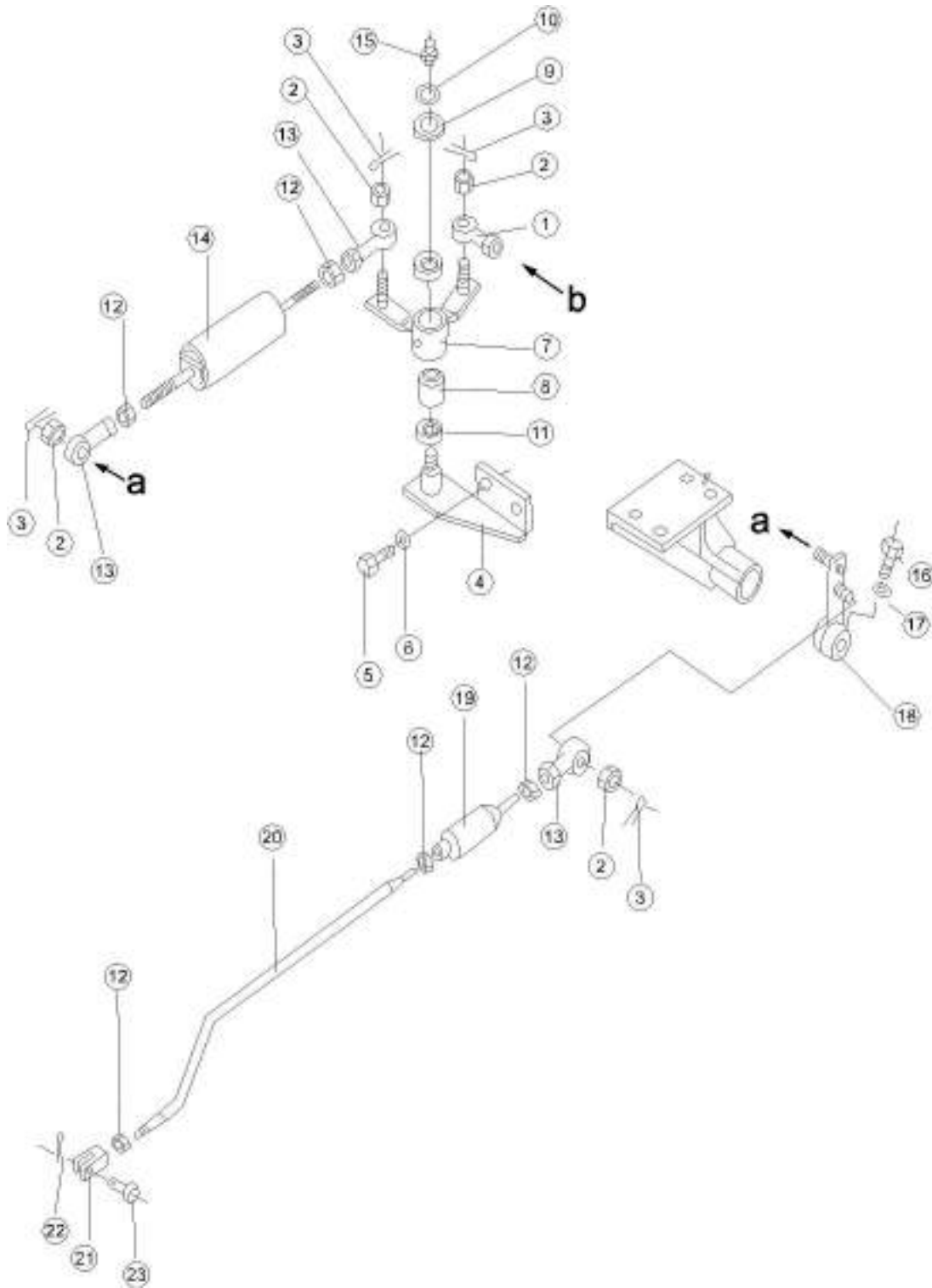

零件图册 | 发动机关联部件

序号 NO.	部件号 PART NO.	零件名称 PART NAME		数量 Q'TY	适用机型 MODEL
1	175-43-25170	关节轴承	Joint bearing	1	
2	01593-31008	螺母 M10*1.25	Nut M10*1.25	4	
3	04050-12018	开口销	Cotter pin	4	
4	175-43-41632	支架	Bracket	1	
5	01010-51230	螺栓 M12*30	Bolt M12*30	2	
6	01643-31232	垫圈 12	Washer 12	2	
7	175-43-41623	摇臂	Rocker arm	1	
8	GB290-HK2016	冲压外圈滚针轴承	Needle roller bearing	1	
9	01640-21826	垫圈 18	Washer 18	1	
10	04064-01812	挡圈	Retainer ring	1	
11	06122-02004	防尘密封圈	Ring, Dust	2	
12	01582-11008	螺母 M10*1.25	Nut M10*1.25	5	
13	04250-41056	关节轴承	Joint bearing	3	
14	175-43-C1191	杆	Lever	1	
15	07020-01021	油杯 M10*1	Oil cup M10*1	1	
16	01010-50830	螺栓 M8*30	Bolt M8*30	1	
17	01602-20825	垫圈 8	Washer 8	1	
18	175-43-C1151	摇臂	Rocker arm	1	
19	175-43-34500	减震器	Damper	1	
20	175-43-C1121	杆	Lever	1	
21	175-43-C1130	叉轴	Shaft	1	
22	04050-12012	开口销	Cotter pin	1	
23	04205-10826	销轴	Pin shaft	1	

# 减速踏板 DECELERATOR PEDAL

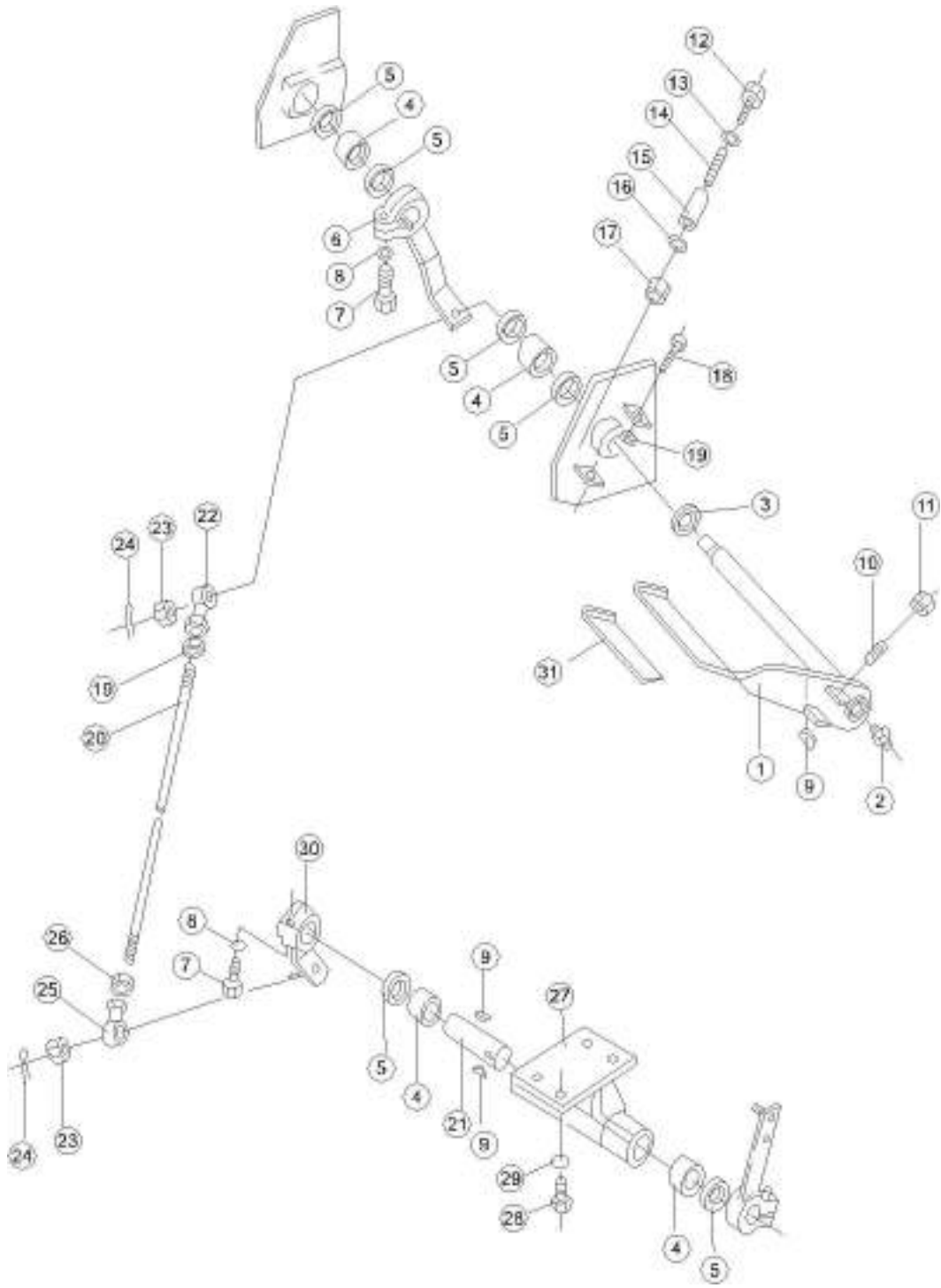

零件图册 | 发动机关联部件

序号 NO.	部件号 PART NO.	零件名称 PART NAME		数量 Q'TY	适用机型 MODEL
1	154-43-14573A	踏板	Pedal	1	
2	07020-01021	油杯 M10*1	Oil cup M10*1	2	
3	01640-22032	垫圈 20	Washer 20	1	
4	GB290-HK2016	冲压外圈滚针轴承	Needle roller bearing	4	
5	06122-02004	防尘密封圈	Ring, Dust	6	
6	171-05-01000	摇臂	Rocker arm	1	
7	01010-50830	螺栓 M8*30	Bolt M8*30	2	
8	01602-20825	垫圈 8	Washer 8	2	
9	04010-10519	半圆键	Woodruff Key	3	
10	175-43-35210	螺钉	Screw	1	
11	01582-11008	螺母 M10*1.25	Nut M10*1.25	1	
12	01010-51055	螺栓 M10*55	Bolt M10*55	1	
13	175-43-35230	衬垫	Gasket	1	
14	175-43-35190	弹簧	Spring	1	
15	175-43-35220	轴环	Shaft ring	1	
16	01643-31032	垫圈 10	Washer 10	1	
17	01580-11008	螺母 M10	Nut M10	1	
18	01016-50845	螺栓 M8*45	Bolt M8*45	1	
19	01580-10806	螺母 M8	Nut M8	2	
20	04248-30832	杆	Lever	1	
21	175-43-41680	轴	Shaft	1	
22	04250-40847	关节轴承	Joint bearing	2	
23	01590-30809	螺母 M8	Nut M8	2	
24	04050-12016	开口销	Cotter pin	2	
25	04250-60847	关节轴承	Joint bearing	1	
26	01508-40805	螺母 M8 左	Nut (L.H.) M8	1	
27	175-43-41671	支架	Bracket	1	
28	01010-51235	螺栓 M12*35	Bolt M12*35	4	
29	01643-31232	垫圈 12	Washer 12	4	
30	175-43-C1210	摇臂	Rocker arm	1	
31	17Y-05-00016	橡胶板	Rubber sheet	1	

风扇  
**FAN**

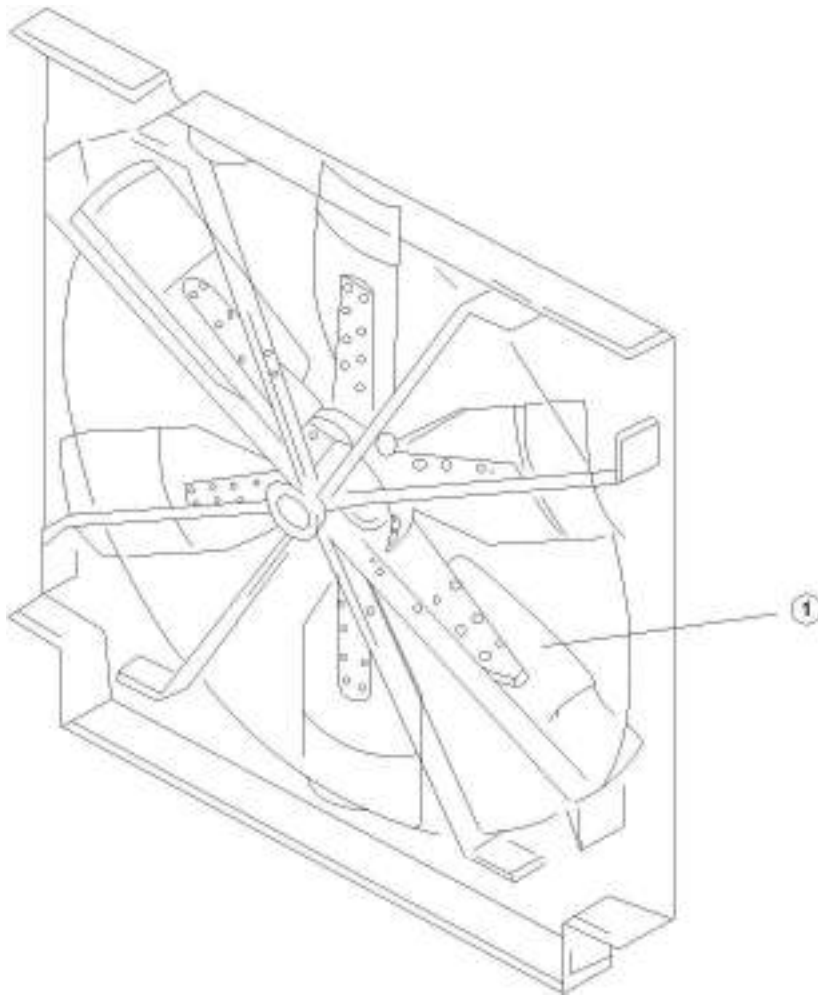

零件图册 | 发动机关联部件

序号 NO.	部件号 PART NO.	零件名称 PART NAME	数量 Q'TY	适用机型 MODEL
1	600-613-1140	风扇 Fan	1	

# 散热器 RADIATOR

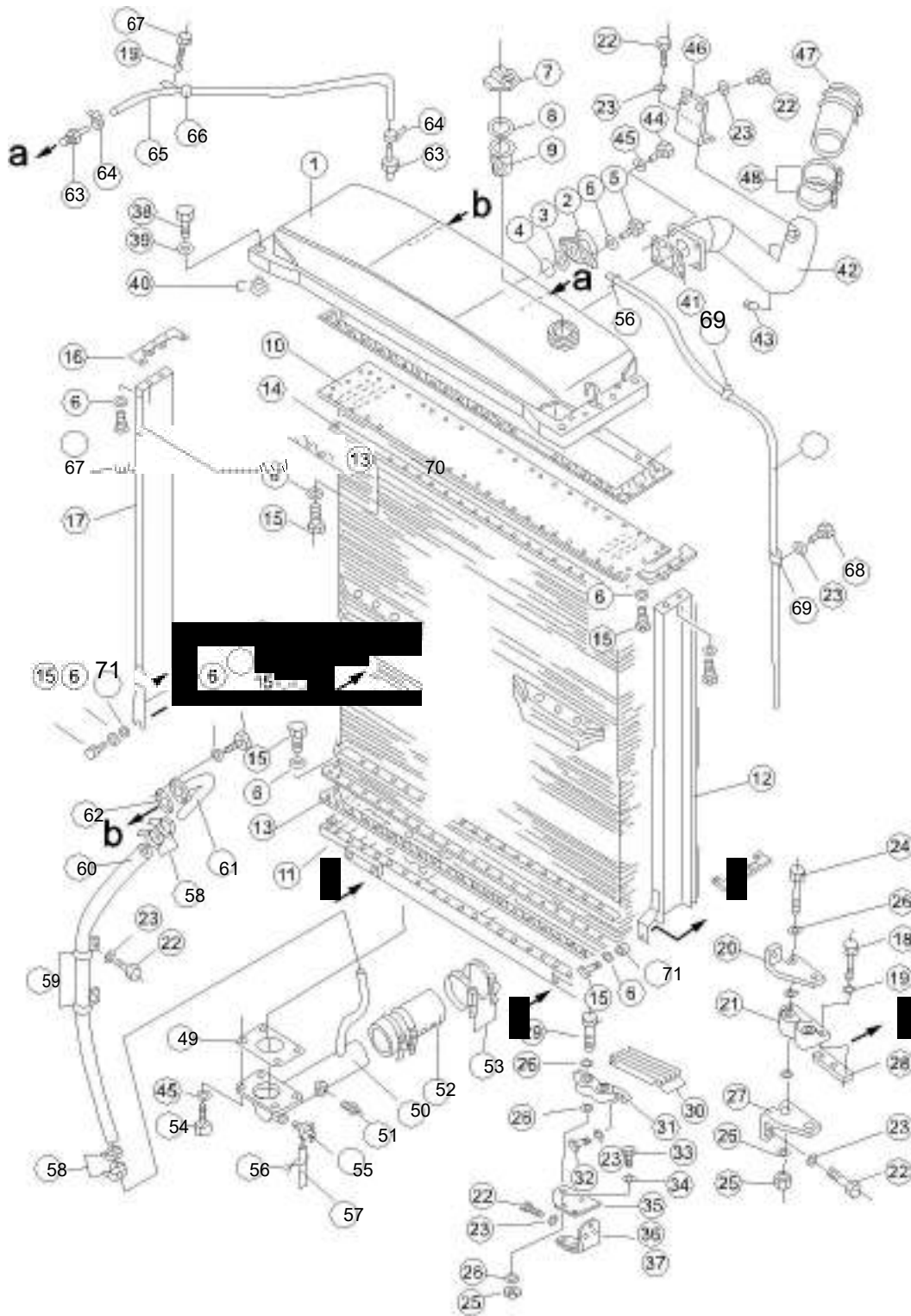

序号 NO.	部件号 PART NO.	零件名称 PART NAME		数量 Q'TY	适用机型 MODEL
0	175-03-C1002	散热器总成	Radiator ass'y	1	
1	175-03-C1111	上箱	Upper tank	1	
2	154-03-11682	压力阀	Pressure valve	1	
3	07000-13045	O 形圈	O-ring	1	
4	175-03-32570	滤网	Filter screen	1	
5	01010-51025	螺栓 M10*25	Bolt M10*25	2	
6	01602-21030	垫圈 10	Washer 10	108	
7	07053-10000	加水口盖	Filler cap	1	
8	07057-03271	卡环	Snap ring	1	
9	07056-00048	过滤网	Filter screen	1	
10	175-03-32261	芯子	Core	1	
11	175-03-31133	下箱	Lower tank	1	
12	175-03-32940	遮护板 ( 右 )	Cover shield (R.H.)	1	
13	175-03-31153	衬垫	Gasket	2	
14	175-03-31181	板	Plate	4	
15	01010-51030	螺栓 M10*30	Bolt M10*30	102	
16	175-03-32990	板	Plate	4	
17	175-03-32930	遮护板 ( 左 )	Cover shield (L.H.)	1	
18	01010-51075	螺栓 M10*75	Bolt M10*75	6	
19	01643-31032	垫圈 10	Washer 10	7	
20	175-03-32961	支架	Bracket	2	
21	195-03-22401	减震器	Damper	2	
22	01010-51225	螺栓 M12*25	Bolt M12*25	19	
23	01643-31232	垫圈 12	Washer 12	26	
24	01091-52220	螺栓 M22*1.5*120	Bolt M22*1.5*120	4	
25	01582-12218	螺母 M22*1.5	Nut M22*1.5	8	
26	01643-32260	垫圈 22	Washer 22	28	
27	175-03-32951	支架	Bracket	2	
28	198-03-21530	压板	Binder plate	2	
29	01091-52205	螺栓 M22*1.5*105	Bolt M22*1.5*105	4	
30	195-03-22270	垫片	Shim	12	
31	195-03-22501	减震器	Damper	2	
32	01010-51245	螺栓 M12*45	Bolt M12*45	4	
33	01010-51435	螺栓 M14*35	Bolt M14*35	4	
34	01643-31445	垫圈 14	Washer 14	4	
35	175-03-32972	支架	Bracket	2	
36	175-03-32770	托架 ( 右 )	Bracket (R.H.)	1	

# 散热器 RADIATOR

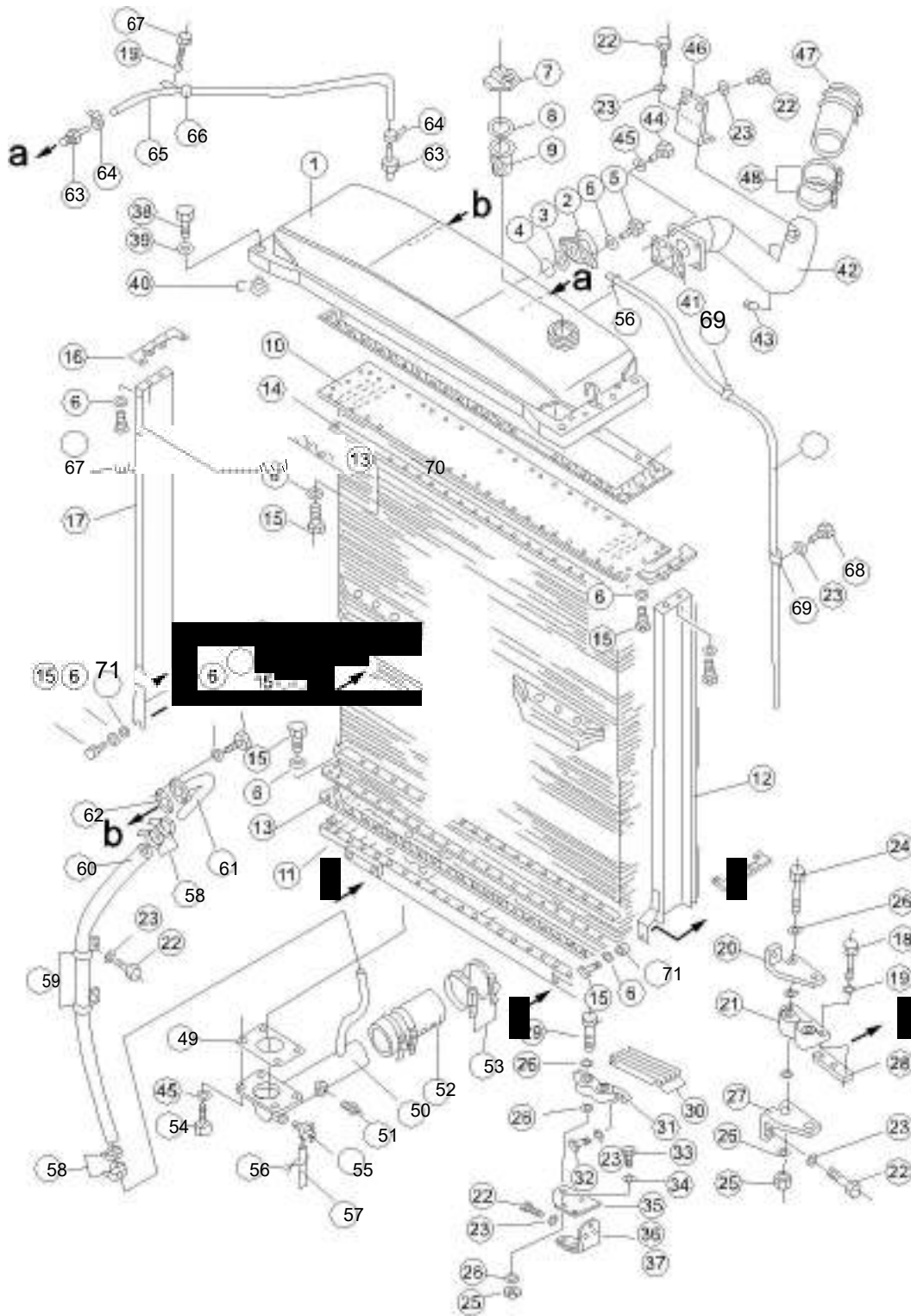

零件图册 | 发动机关联部件

序号 NO.	部件号 PART NO.	零件名称 PART NAME	数量 Q'TY	适用机型 MODEL
37	175-03-32760	托架 ( 左 ) Bracket (L.H.)	1	
38	01011-51835	螺栓 M18*135 Bolt M18*135	4	
39	175-03-32650	套 Sleeve	4	
40	195-03-11570	垫片 Shim	8	
41	195-03-11340	垫 Pad	1	
42	175-03-C1320	管 Tube	1	
43	07042-20108	螺塞 Screw plug	1	
44	01010-51230	螺栓 M12*30 Bolt M12*30	5	
45	01602-21236	垫圈 12 Washer 12	8	
46	175-03-C1340	托架 Bracket	1	
47	175-03-C1330	软管 Hose	1	
48	07280-07429	管夹 Clip	4	
49	195-03-11361	填密垫 Gasket	1	
50	175-03-C1350	管 Tube	1	
51	07042-20415	螺塞 Screw plug	1	
52	175-03-C1380	软管 Hose	1	
53	07280-08029	管夹 Clip	4	
54	01010-51235	螺栓 M12*35 Bolt M12*35	4	
55	195-03-13241	阀 Valve	1	
56	04059-01010	铁丝 Iron wire	2	
57	175-03-31530	软管 Hose	1	
58	07280-03826	管夹 Clip	4	
59	175-03-C1370A	夹 Clip	2	
60	175-03-C1360	软管 Hose	1	
61	175-03-C1121	管 Tube	1	
62	195-03-11980	垫 Pad	1	
63	195-03-11530	接头 Nipple	2	
64	07281-00197	喉箍 Hose Clamp	2	
65	175-03-C1420	软管 Hose	1	
66	195-03-11580	夹子 Clamp	1	
67	01010-51020	螺栓 M10*20 Bolt M10*20	5	
68	01010-51220	螺栓 M12*20 Bolt M12*20	3	
69	195-03-11690	夹子 Clamp	3	
70	195-03-13131	管 Tube	1	
71	195-03-22160	座 Seat	2	

# 散热器风扇防护网罩 RADIATOR FAN GUARD AND NET

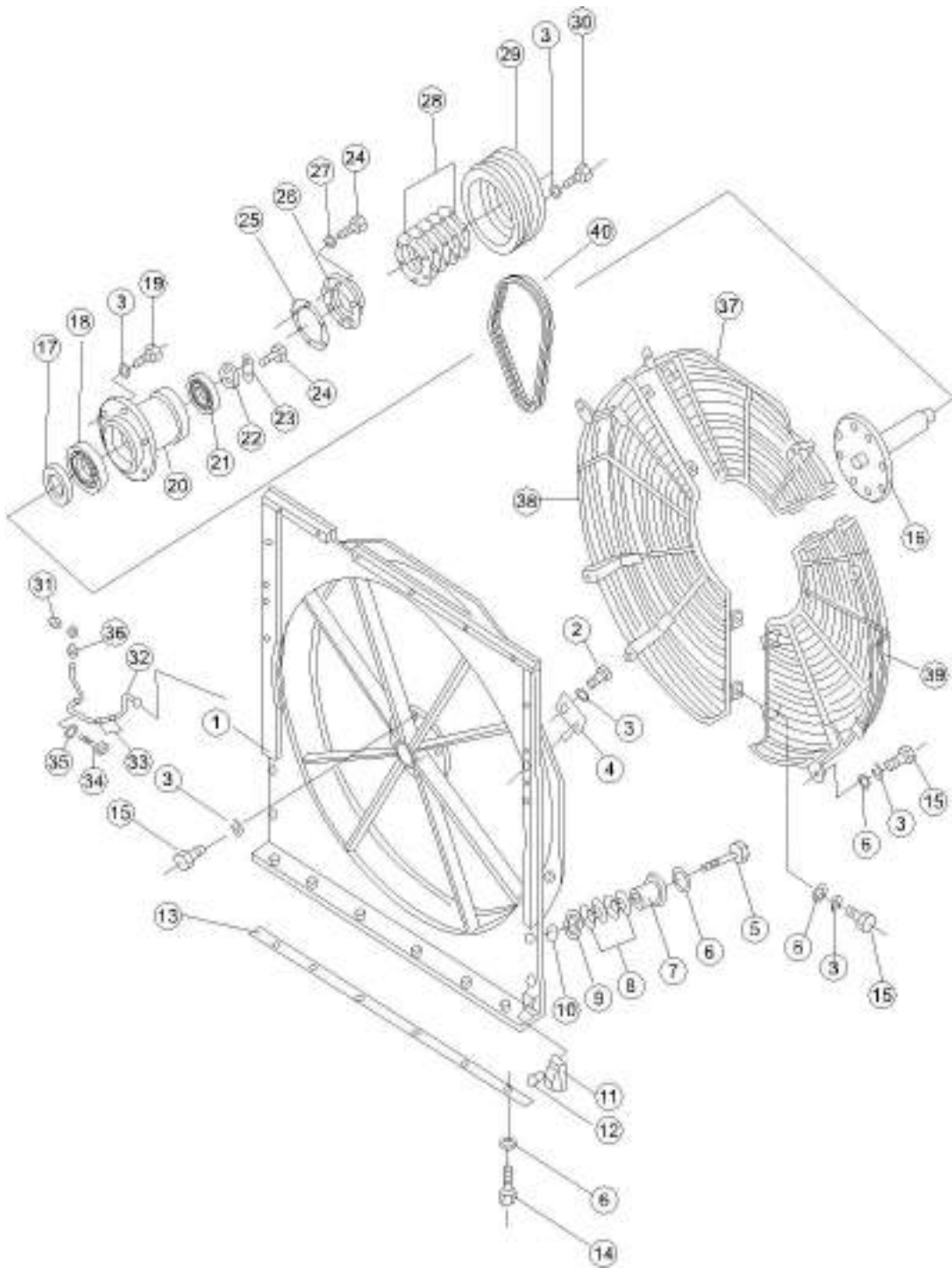

序号 NO.	部件号 PART NO.	零件名称 PART NAME		数量 Q'TY	适用机型 MODEL
0	175-03-C1002	散热器总成	Radiator ass'y	1	
1	175-03-C1142	保护架	Holder	1	
2	01010-51230	螺栓 M12*30	Bolt M12*30	1	
3	01602-21236	垫圈 12	Washer 12	25	
4	175-03-32710A	销	Pin	1	
5	01010-51275	螺栓 M12*75	Bolt M12*75	10	
6	01643-31232	垫圈 12	Washer 12	28	
7	175-03-32232	套	Sleeve	10	
8	175-54-27350	弹簧	Spring	40	
9	01643-32060	垫圈 20	Washer 20	10	
10	175-54-28770	卡环	Snap ring	10	
11	195-03-13150	压板	Binder plate	2	
12	01010-51020	螺栓 M10*20	Bolt M10*20	4	
13	175-03-32720	板	Plate	1	
14	01010-51225	螺栓 M12*25	Bolt M12*25	4	
15	01010-51235	螺栓 M12*35	Bolt M12*35	22	
16	175-03-C1271	轴	Shaft	1	
17	07011-00090	骨架油封	Oil seal	1	
18	GB276-6212C4	深沟球轴承	Deep groove ball bearings	1	
19	01010-51240	螺栓 M12*40	Bolt M12*40	6	
20	175-03-C1280	筒	Drum	1	
21	GB272-6310C4	深沟球轴承	Deep groove ball bearings	1	
22	195-03-11842	挡圈	Retainer ring	1	
23	195-03-11851	锁片	Locking plate	1	
24	01010-51030	螺栓 M10*30	Bolt M10*30	5	
25	195-03-11870	垫	Pad	1	
26	175-03-34380	盖	Cover	1	
27	01602-21030	垫圈 10	Washer 10	3	
28	195-03-11880	填片	Shim	10	
29	175-03-C1290	皮带轮	Pulley	1	
30	01010-51260	螺栓 M12*60	Bolt M12*60	6	
31	07020-01021	油杯 M10*1	Oil cup M10*1	1	
32	175-03-C1470	管	Tube	1	
33	566-16-11970	管夹	Clip	2	
34	01010-50816	螺栓 M8*16	Bolt M8*16	2	
35	01643-30823	垫圈 8	Washer 8	2	
36	07213-80710	接头	Nipple	1	

# 散热器风扇防护网罩 RADIATOR FAN GUARD AND NET

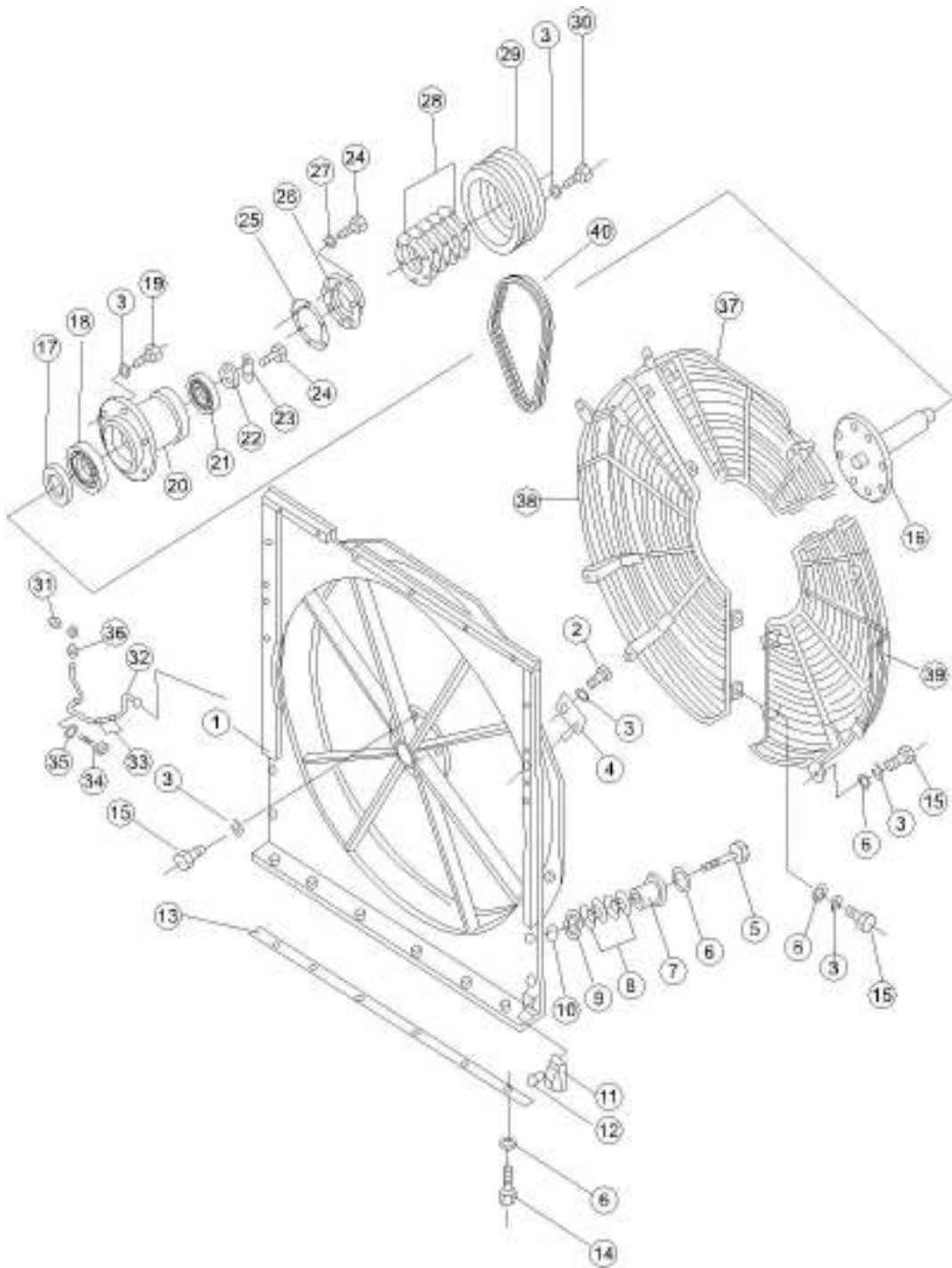

零件图册 | 发动机关联部件

序号 NO.	部件号 PART NO.	零件名称 PART NAME	数量 Q'TY	适用机型 MODEL
37	175-03-C1250	网罩 Cover	1	
38	175-03-C1241	网罩 Cover	1	
39	175-03-C1261	网罩 Cover	1	
40	04122-22279	V 形皮带 V-shaped belt	1	

### 散热器及其管路 (配国 II 发动机) RADIATOR AND PIPING (GOING WITH THE NATIONAL II-ENGINE)

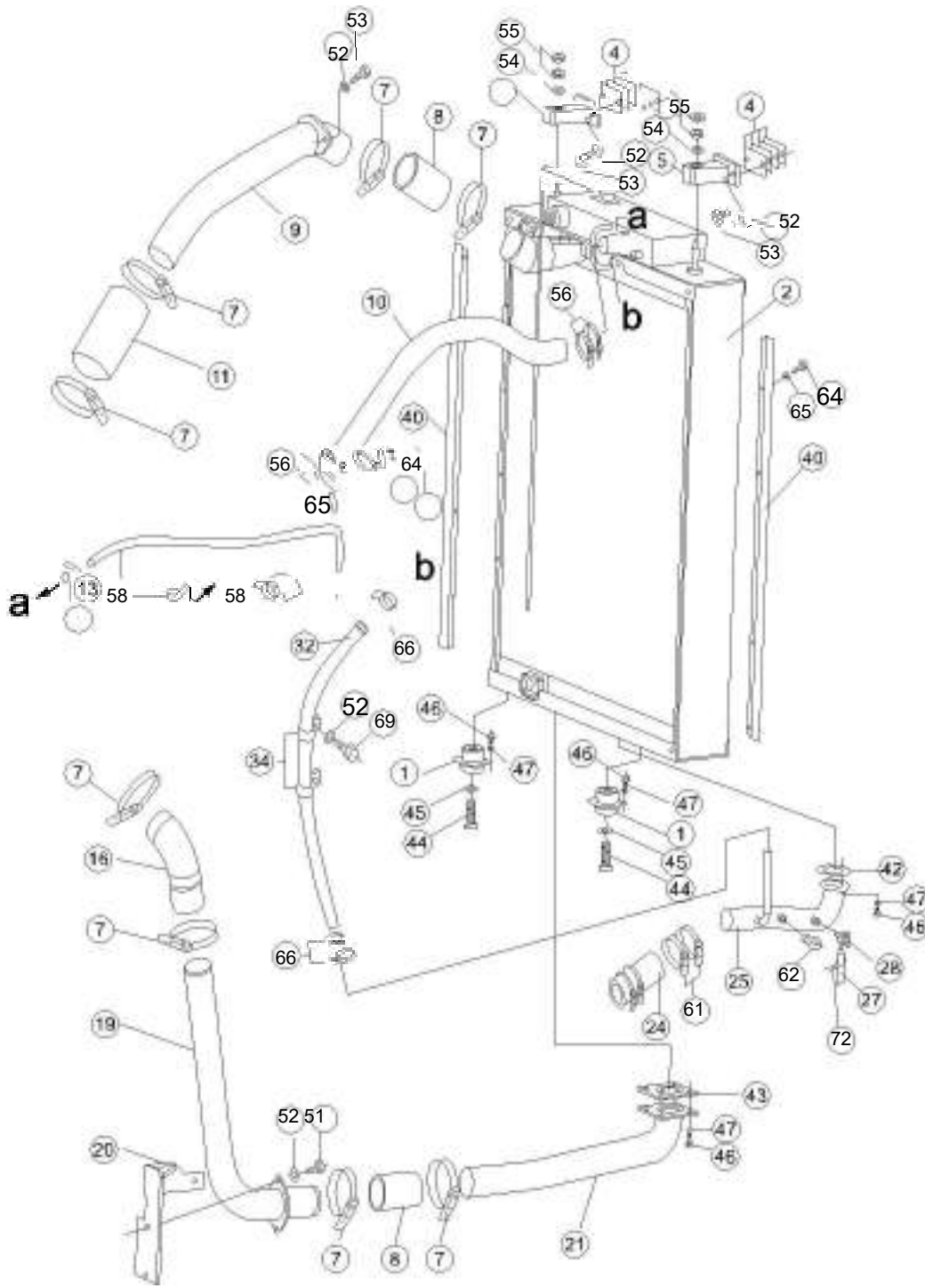

零件图册 | 发动机关联部件

序号 NO.	部件号 PART NO.	零件名称 PART NAME	数量 Q'TY	适用机型 MODEL
1	23Y-03N-09000	减振器 Shock absorber	4	
2	171-03A-01000	散热器 Radiator	1	
4	185-03-00010	垫 Pad	8	
5	23Y-03N-06000	座 Seat	4	
7	156-03-02000	卡箍 Clamp	8	
8	171-03A-03000	软管 Hose	2	
9	171-03A-04000	管 Tube	1	
10	171-03A-05000	软管 Hose	1	
11	171-03A-06000	软管 Hose	1	
13	175-03-C1420	软管 Hose	1	
16	171-03A-07000	软管 Hose	1	
19	171-03A-08000	管 Tube	1	
20	171-03A-09000	支架 Bracket	1	
21	171-03A-10000	管 Tube	1	
24	175-03-C1380	软管 Hose	1	
25	171-03A-11000	管 Tube	1	
27	175-03-31530	软管 Hose	1	
28	195-03-13241	阀 Valve	1	
32	171-03A-00001	软管 Hose	1	
34	175-03-C1370A	夹 Clip	2	
40	171-03A-14000	护风罩 Guard	2	
42	171-03A-00002	填密垫 Gasket	1	
43	171-03A-00003	填密垫 Gasket	1	
44	01010-52095	螺栓 M20*95 Bolt M20*95	4	
45	01643-32060	垫圈 20 Washer 20	4	
46	01010-51025	螺栓 M10*25 Bolt M10*25	14	
47	01643-31032	垫圈 10 Washer 10	14	
52	01643-31232	垫圈 12 Washer 12	10	
53	01010-51230	螺栓 M12*30 Bolt M12*30	6	
54	01643-32260	垫圈 22 Washer 22	2	
55	01580-12218	螺母 M22 Nut M22	4	
56	07280-07429	管夹 Clip	4	
58	07281-00197	喉箍 Hose Clamp	2	
61	07280-08029	管夹 Clip	4	
62	07042-20415	螺塞 Screw plug	1	
64	01010-50816	螺栓 M8*16 Bolt M8*16	10	
65	01643-30823	垫圈 8 Washer 8	10	

### 散热器及其管路 (配国 II 发动机) RADIATOR AND PIPING (GOING WITH THE NATIONAL II-ENGINE)

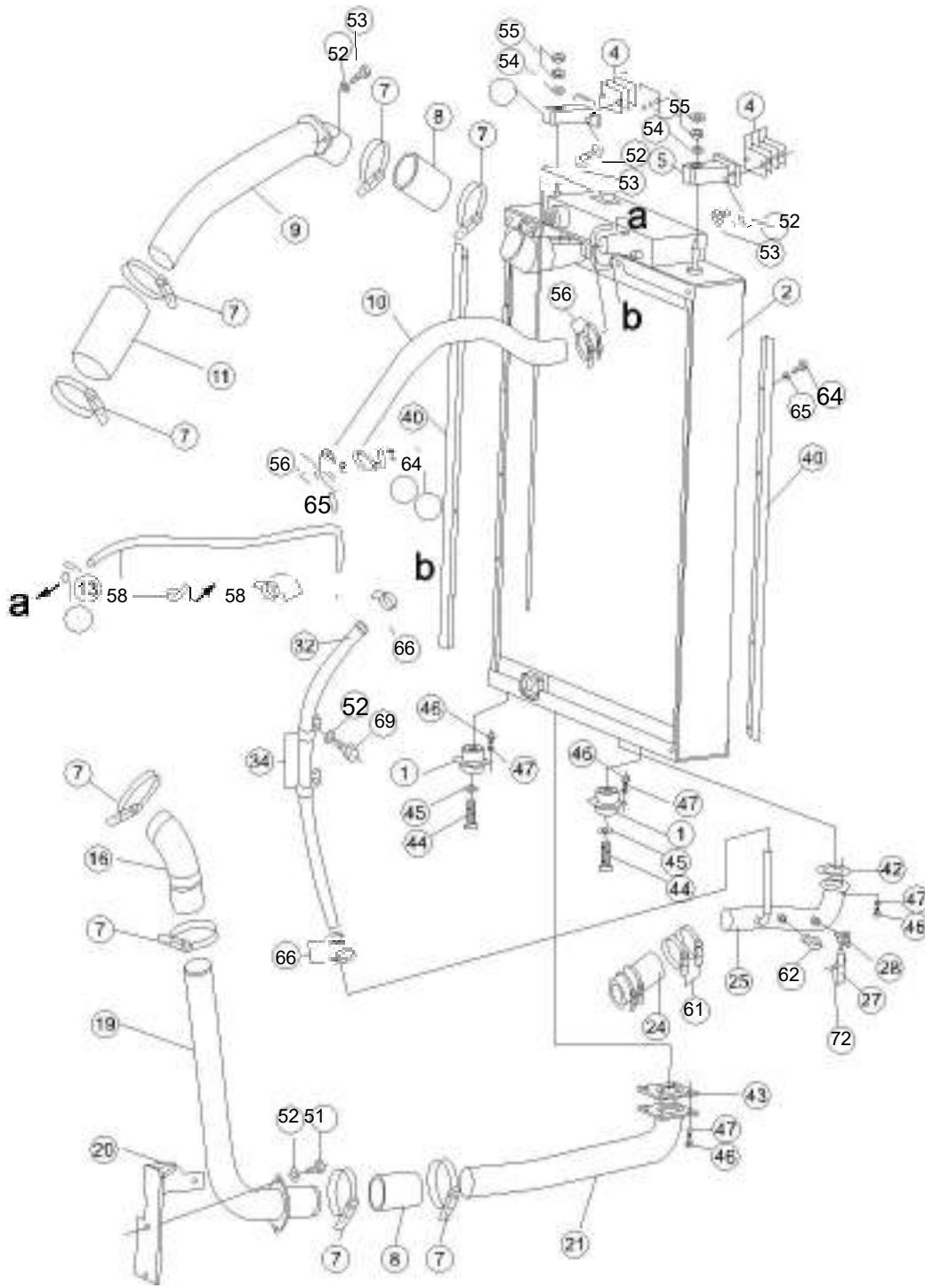

零件图册 | 发动机关联部件

序号 NO.	部件号 PART NO.	零件名称 PART NAME	数量 Q'TY	适用机型 MODEL
66	07280-03826	管夹 Clip	4	
69	01010-51225	螺栓 M12*25 Bolt M12*25	2	
72	04059-01010	铁丝 Iron wire	1	

### 散热器及其管路 (配国 II 发动机) RADIATOR AND PIPING (GOING WITH THE NATIONAL II-ENGINE)

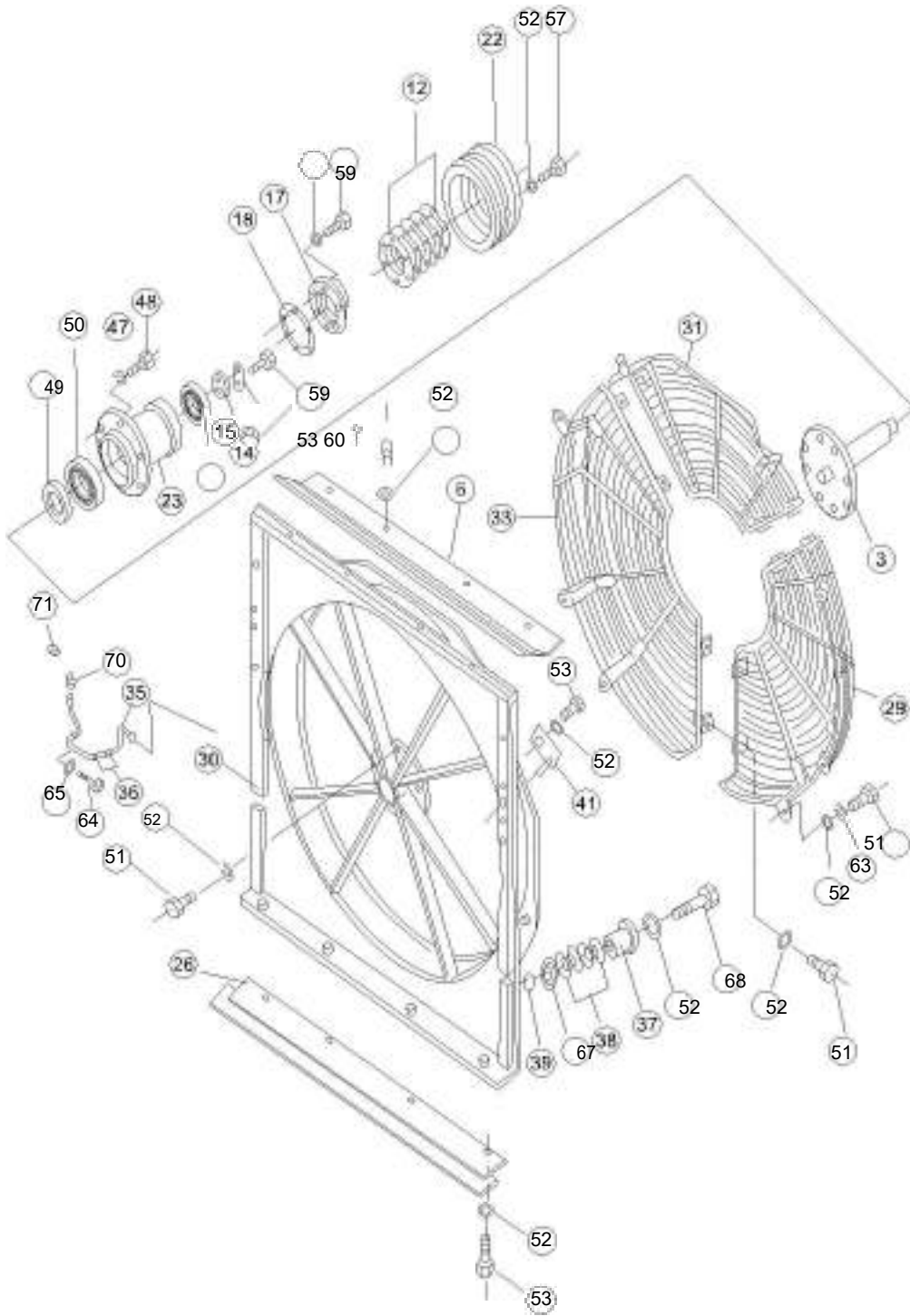

零件图册 | 发动机关联部件

序号 NO.	部件号 PART NO.	零件名称 PART NAME	数量 Q'TY	适用机型 MODEL
3	175-03-C1271	轴 Shaft	1	
6	171-03A-02000	护风罩 Guard	1	
12	195-03-11880	填片 Shim	10	
14	195-03-11842	挡圈 Retainer ring	1	
15	195-03-11851	锁片 Locking plate	1	
17	175-03-34380	盖 Cover	1	
18	195-03-11870	垫 Pad	1	
22	175-03-C1290	皮带轮 Pulley	1	
23	175-03-C1280	筒 Drum	1	
26	171-03A-12000	护风罩 Guard	1	
29	175-03-C1261	网罩 Cover	1	
30	171-03A-13000	保护架 Holder	1	
31	175-03-C1250	网罩 Cover	1	
33	175-03-C1241	网罩 Cover	1	
35	175-03-C1470	管 Tube	1	
36	566-16-11970	管夹 Clip	2	
37	175-03-32232	套 Sleeve	10	
38	175-54-27350	弹簧 Spring	40	
39	175-54-28770	卡环 Snap ring	10	
41	175-03-32710A	销 Pin	1	
47	01643-31032	垫圈 10 Washer 10	9	
48	01010-51240	螺栓 M12*40 Bolt M12*40	6	
49	07011-00090	骨架油封 Oil seal	1	
50	GB276-6212C4	深沟球轴承 Deep groove ball bearings	1	
51	01010-51235	螺栓 M12*35 Bolt M12*35	24	
52	01643-31232	垫圈 12 Washer 12	55	
53	01010-51230	螺栓 M12*30 Bolt M12*30	9	
57	01010-51260	螺栓 M12*60 Bolt M12*60	6	
59	01010-51030	螺栓 M10*30 Bolt M10*30	5	
60	GB276-6310C4	深沟球轴承 Deep groove ball bearings	1	
63	01602-21236	垫圈 12 Washer 12	8	
64	01010-50816	螺栓 M8*16 Bolt M8*16	2	
65	01643-30823	垫圈 8 Washer 8	2	
67	01643-32060	垫圈 20 Washer 20	10	
68	01010-51275	螺栓 M12*75 Bolt M12*75	10	
70	07213-80710	接头 Nipple	1	
71	07020-01021	油杯 M10*1 Oil cup M10*1	1	

# 油冷器总成 OIL COOLER ASS'Y

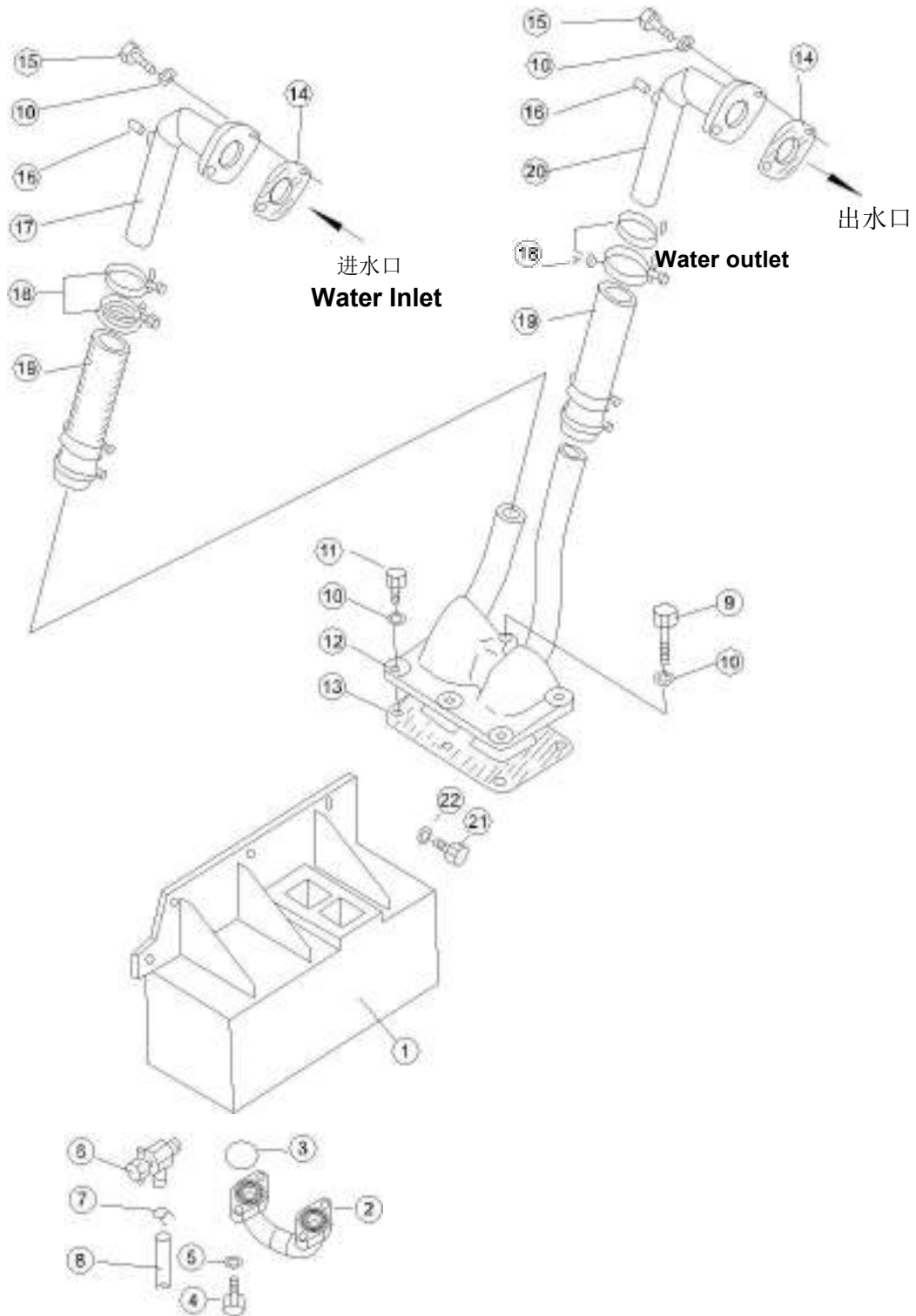

零件图册 | 发动机关联部件

序号 NO.	部件号 PART NO.	零件名称 PART NAME		数量 Q'TY	适用机型 MODEL
1	175-03-C2100A	油冷器	Oil cooler	1	
2	24Y-03-01000	连接管	Connecting pipe	1	
3	07000-13042	O 形圈	O-ring	2	
4	01010-51230	螺栓 M12*30	Bolt M12*30	4	
5	01643-31232	垫圈 12	Washer 12	4	
6	195-03-13241	阀	Valve	1	
7	GB3081-82	铁丝	Iron wire	1	
8	175-03-31530	软管	Hose	1	
9	01010-51070	螺栓 M10*70	Bolt M10*70	1	
10	01602-21030	垫圈 10	Washer 10	10	
11	01010-51030	螺栓 M10*30	Bolt M10*30	5	
12	175-03-C2171	管	Tube	1	
13	175-03-C2180	垫	Pad	1	
14	175-03-C2160	垫	Pad	2	
15	02010-70632	螺栓	Bolt	4	
16	07042-20108	螺塞	Screw plug	2	
17	175-03-C2150	管	Tube	1	
18	07280-05429	管夹	Clip	8	
19	07260-04116	软管	Hose	2	
20	175-03-C2220	管	Tube	1	
21	01010-51645	螺栓 M16*45	Bolt M16*45	5	
22	01643-31645	垫圈 16	Washer 16	5	

# 燃油箱 FUEL TANK

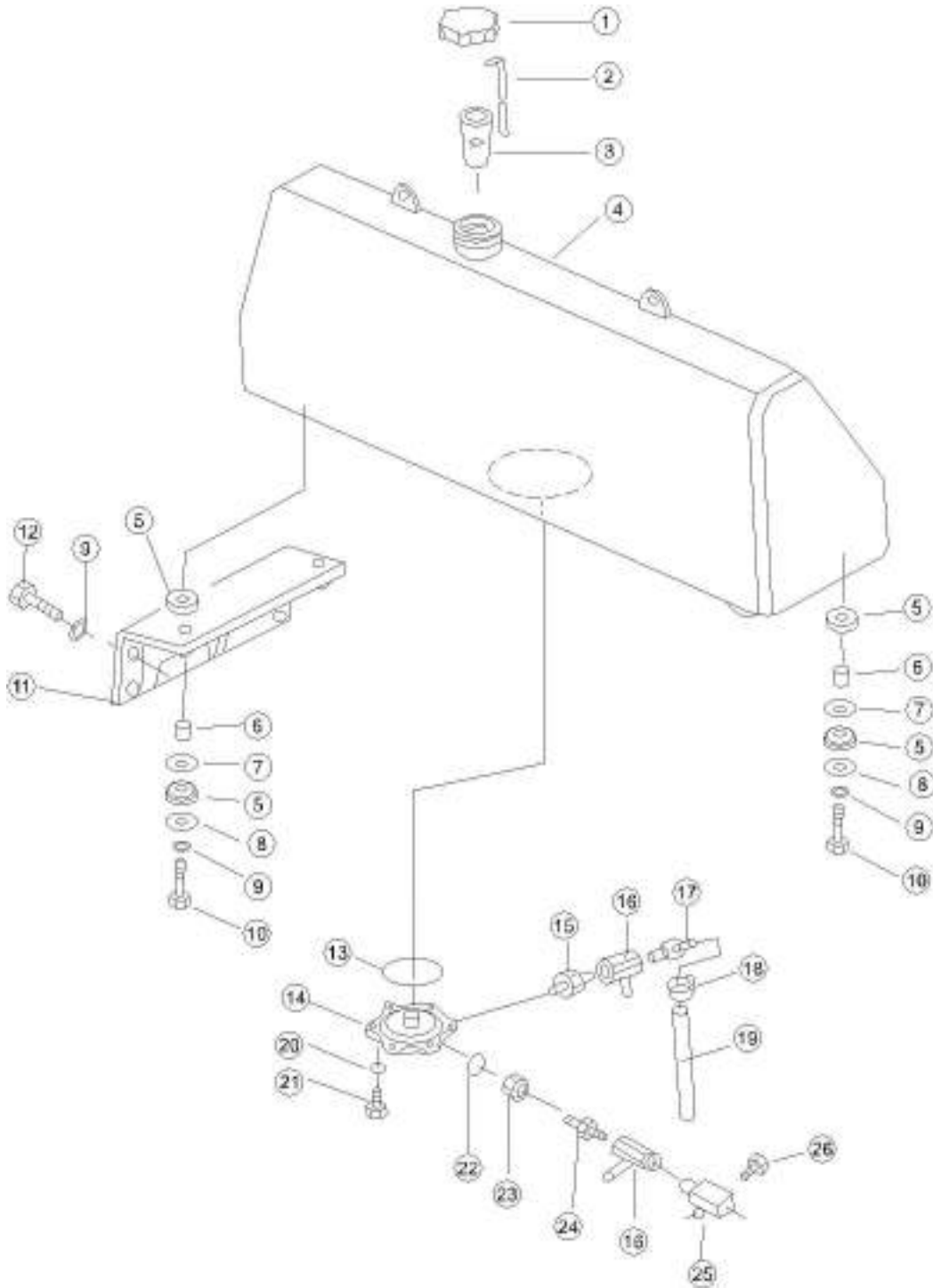

零件图册 | 发动机关联部件

序号 NO.	部件号 PART NO.	零件名称 PART NAME		数量 Q'TY	适用机型 MODEL
1	16Y-04C-02000	油箱盖	Fuel tank cap	1	
2	171-04-00001	油尺	Dipstick	1	
3	07056-18416	过滤网	Filter screen	1	
4	171-04-01000	燃油箱	Fuel tank	1	
5	14Y-04-00001	减震垫	Cushion	12	
6	14Y-04-00002	套	Sleeve	6	
7	14Y-04-00003	垫板	Plate	6	
8	14Y-04-00004	垫板	Plate	6	
9	01643-32060	垫圈 20	Washer 20	12	
10	01010-52075	螺栓 M20*75	Bolt M20*75	6	
11	24Y-04-20000	托架	Bracket	1	
12	01010-52065	螺栓 M20*65	Bolt M20*65	6	
13	07000-05290	O 形圈	O-ring	1	
14	171-04-02000	法兰盘	Flange	1	
15	24Y-04-00005	接头	Nipple	1	
16	07700-40460	阀门	Valve	2	
17	24Y-04-00004	放水接头	Drain Nipple	1	
18	07280-01210	管夹	Clip	1	
19	07270-01265	软管	Hose	1	
20	01643-31032	垫圈 10	Washer 10	10	
21	01010-51025	螺栓 M10*25	Bolt M10*25	10	
22	07002-02434	O 形圈	O-ring	1	
23	07239-12410	螺母	Nut	3	
24	24Y-04-00008	接头	Nipple	1	
25	24Y-04-00009	弯头	Elbow	1	
26	07042-20108	螺塞	Screw plug	1	

# 燃油管路 FUEL PIPING

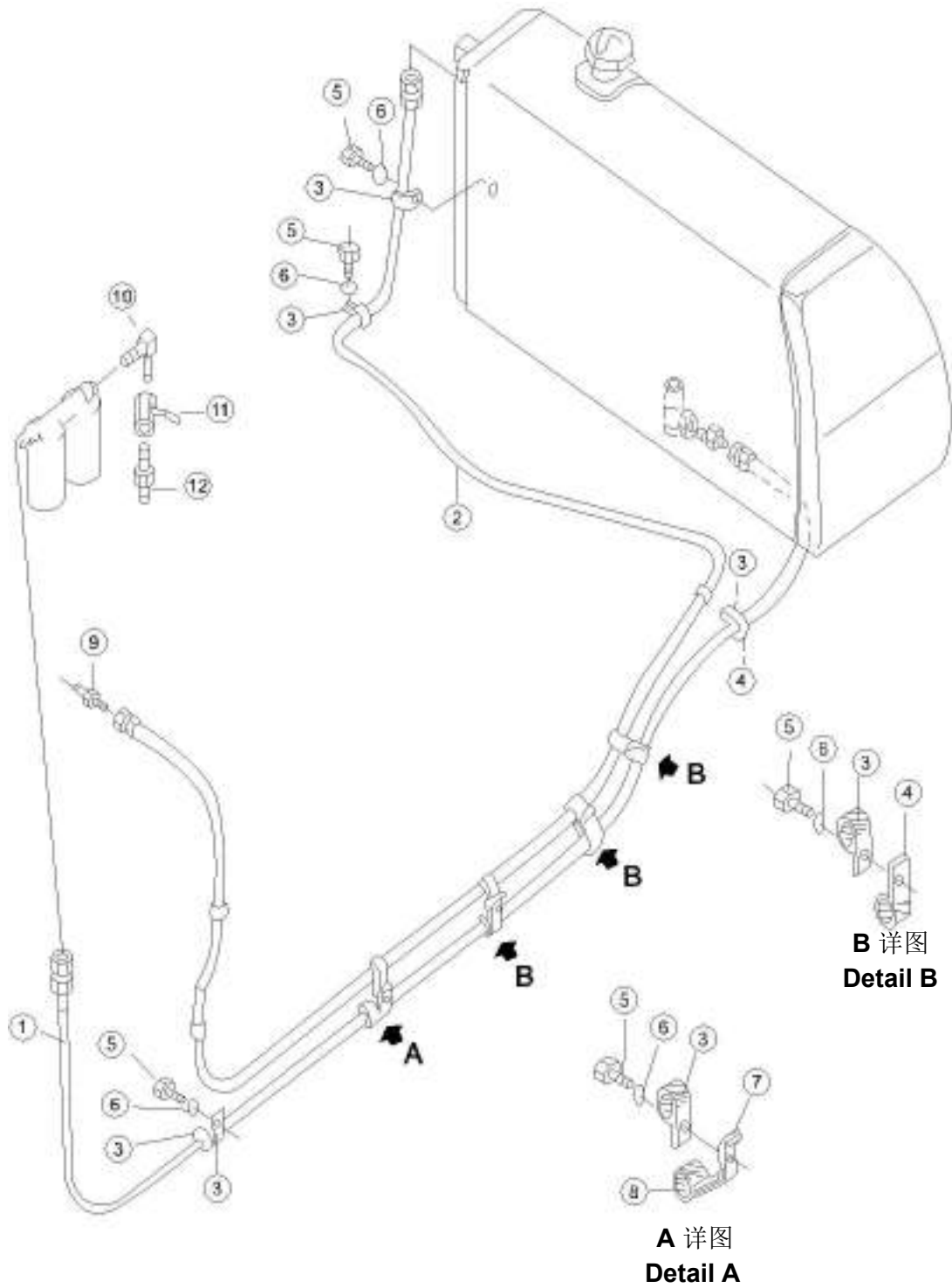

零件图册 | 发动机关联部件

序号 NO.	部件号 PART NO.	零件名称 PART NAME		数量 Q'TY	适用机型 MODEL
1	24Y-04-40000	进油管	Tube, Oil feed	1	
2	24Y-04-30000	回油管	Scavenge pipe	1	
3	08036-12514	线夹	Wire clip	8	
4	08035-03010	线夹	Wire clip	6	
5	01010-51016	螺栓 M10*16	Bolt M10*16	7	
6	01643-31032	垫圈 10	Washer 10	7	
7	24Y-04-00002	夹板	Plate	2	
8	24Y-04-00003	管	Tube	1	
9	24Y-04-00010	接头	Nipple	1	
10	23Y-04-00007	接头	Nipple	1	
11	07700-40460	阀门	Valve	1	
12	23Y-04-00008	接头	Nipple	1	

# 加油泵总成 FILLING PUMP ASS'Y

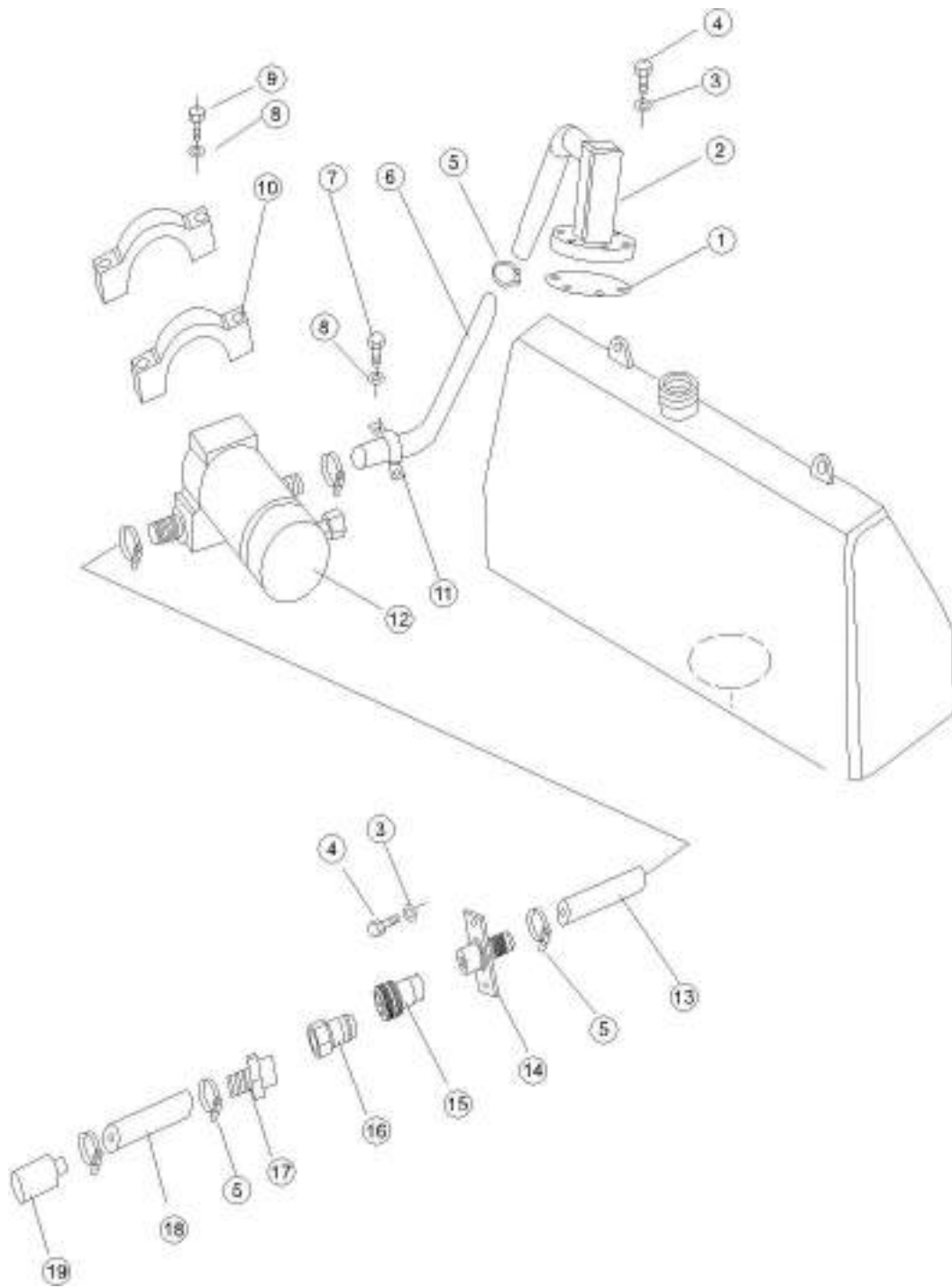

零件图册 | 发动机关联部件

序号 NO.	部件号 PART NO.	零件名称 PART NAME		数量 Q'TY	适用机型 MODEL
0	171-04-10000	加油泵总成	Filling pump ass'y	1	
1	171-04-00002	密封垫	Gasket	1	
2	171-04-10100	油管	Oil tube	1	
3	01010-50625	螺栓 M6*25	Bolt M6*25	8	
4	01643-30623	垫圈 6	Washer 6	8	
5	07281-00259	喉箍	Hose Clamp	6	
6	09483-10524	软管	Hose	1	
7	01010-51025	螺栓 M10*25	Bolt M10*25	2	
8	01643-31032	垫圈 10	Washer 10	6	
9	01010-51065	螺栓 M10*65	Bolt M10*65	4	
10	171-04-10300	盖	Cover	1	
11	07282-12288	管夹	Clip	1	
12	31Y-04-06000	加油泵	Filling pump	1	
13	09483-10506	软管	Hose	1	
14	171-04-10200	接头	Nipple	1	
15	31Y-04-04000	快速插座	Fast Socket	1	
16	31Y-04-05000	快速插头	Quick plug	1	
17	171-04-10001	接头	Nipple	1	
18	09483-10520	软管	Hose	1	
19	171-04-10400	滤油器	Strainer	1	

A series of horizontal dashed lines for writing notes.

变矩器和变速箱

**TORQUE CONVERTOR AND TRANSMISSION**

# 万向节 UNIVERSAL JOINT

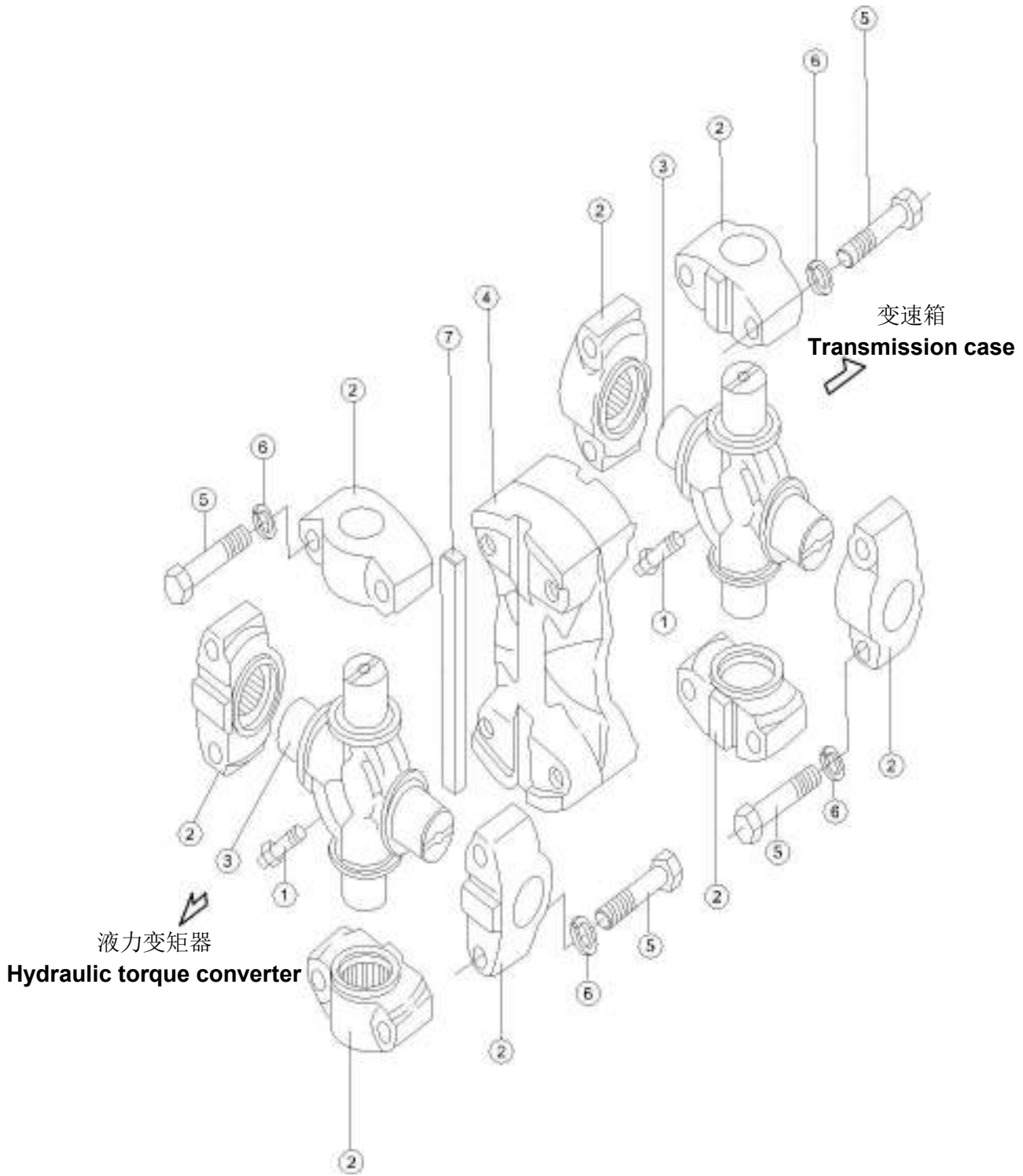

序号 NO.	部件号 PART NO.	零件名称 PART NAME		数量 Q'TY	适用机型 MODEL
1	175-20-11140	油嘴	Oil nozzle	2	
2	175-20-11110	轴承	Bearing	8	
3	175-20-11120	十字轴	Cross shaft	2	
4	175-20-11130	连接板	Junction plate	1	
5	01010-51260	螺栓 M12*60	Bolt M12*60	16	
6	01602-21236	垫圈 12	Washer 12	16	
7	175-20-11100-01	钢板	Steel plate	2	

# 变矩器外壳与阀 TORQUE CONVERTER HOUSING AND VALVE

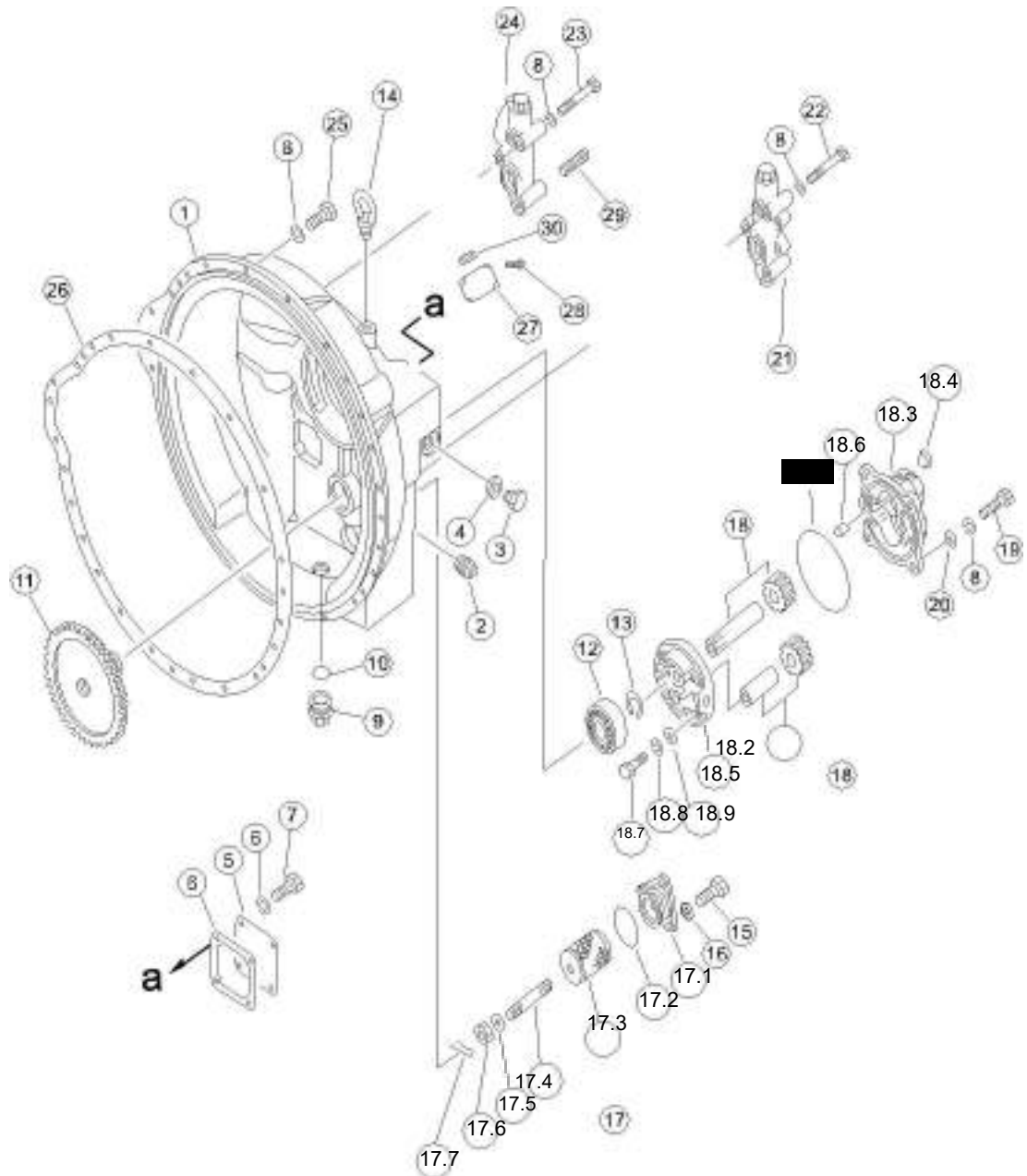

序号 NO.	部件号 PART NO.	零件名称 PART NAME		数量 Q'TY	适用机型 MODEL
0	175-13-21007	变矩器总成	Torque converter ass'y	1	
1	195-13-13114	壳体	Housing body	1	
2	07042-20415	螺塞	Screw plug	3	
3	175-13-23290	螺塞	Screw plug	1	
4	07005-01612	密封垫圈	Sealing gasket	1	
5	175-13-23220	盖	Cover	1	
6	175-13-23231	密封垫	Gasket	1	
7	01010-51225	螺栓 M12*25	Bolt M12*25	4	
8	01602-21236	垫圈 12	Washer 12	37	
9	07044-13620	螺塞	Screw plug	1	
10	07002-23634	O 形圈	O-ring	1	
11	175-13-24111	齿轮	Gear	1	
12	GB296-3206C3	双列角接触球轴承	Double row angular contact ball bearing	1	
13	04064-03015	挡圈	Retainer ring	1	
14	04530-11628	吊环螺钉	Lifting screw	2	
15	01010-51230	螺栓 M12*30	Bolt M12*30	3	
16	01643-31232	垫圈 12	Washer 12	3	
17.20	07000-72070	O 形圈	O-ring	1	
17	134-13-13400	过滤器组件	Strainer ass'y	1	
17.10	134-13-13410	盖	Cover	1	
17.40	134-13-13430	螺栓	Bolt	1	
17.30	195-13-13420	过滤器	Strainer	1	
18	175-13-23500	回油泵总成	Oil scavenger pump ass'y	1	
18.10	175-13-23510	传动齿轮总成	Drive gear ass'y	1	
18.20	175-13-23520	从动齿轮总成	Driven gear ass'y	1	
18.30	175-13-23530	箱总成	Box body ass'y	1	
18.11	07000-72115	O 形圈	O-ring	1	
17.70	04050-11212	开口销	Cotter pin	1	
17.50	01641-20608	垫圈 6	Washer 6	1	
18.40	01190-01011	螺纹衬套	Threaded bushing	2	
17.60	01590-30607	螺母 M6	Nut M6	1	
18.80	01602-20825	垫圈 8	Washer 8	4	
19	01010-51235	螺栓 M12*35	Bolt M12*35	4	
18.90	01641-20812	垫圈 8	Washer 8	4	
18.70	01010-50835	螺栓 M8*35	Bolt M8*35	4	
18.60	04020-00820	圆柱销	Cylindrical pin	2	

# 变矩器外壳与阀 TORQUE CONVERTER HOUSING AND VALVE

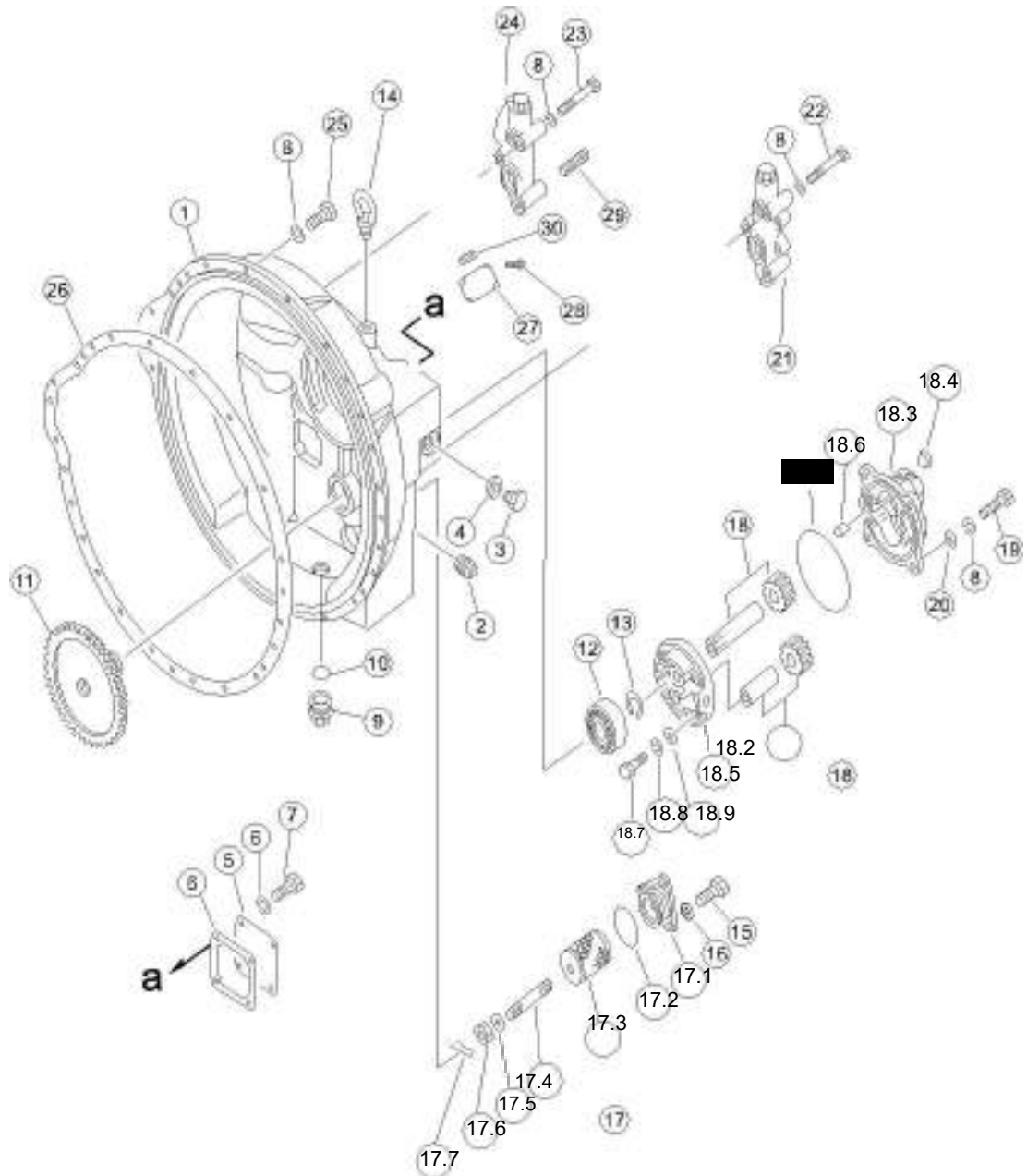

序号 NO.	部件号 PART NO.	零件名称 PART NAME	数量 Q'TY	适用机型 MODEL
18.50	175-13-23540	盖 Cover	1	
20	01641-21223	垫圈 12 Washer 12	4	
21	195-13-16100	溢流阀总成 Overflow valve ass'y	1	
22	01010-51290	螺栓 M12*90 Bolt M12*90	3	
23	01010-51295	螺栓 M12*95 Bolt M12*95	3	
24	175-13-26401	调压阀总成 Pressure-adjusting valve ass'y	1	
25	01010-51240	螺栓 M12*40 Bolt M12*40	23	
26	175-11-11112	垫 Pad	1	
27	09607-05080	标牌 Label plate	1	
28	04418-03060	标牌铆钉 Rivet	4	
29	07042-20108	螺塞 Screw plug	1	
30	07020-00613	油杯 M6 Oil cup M6	1	

# 涡轮导向器 TURBINE AND STATOR

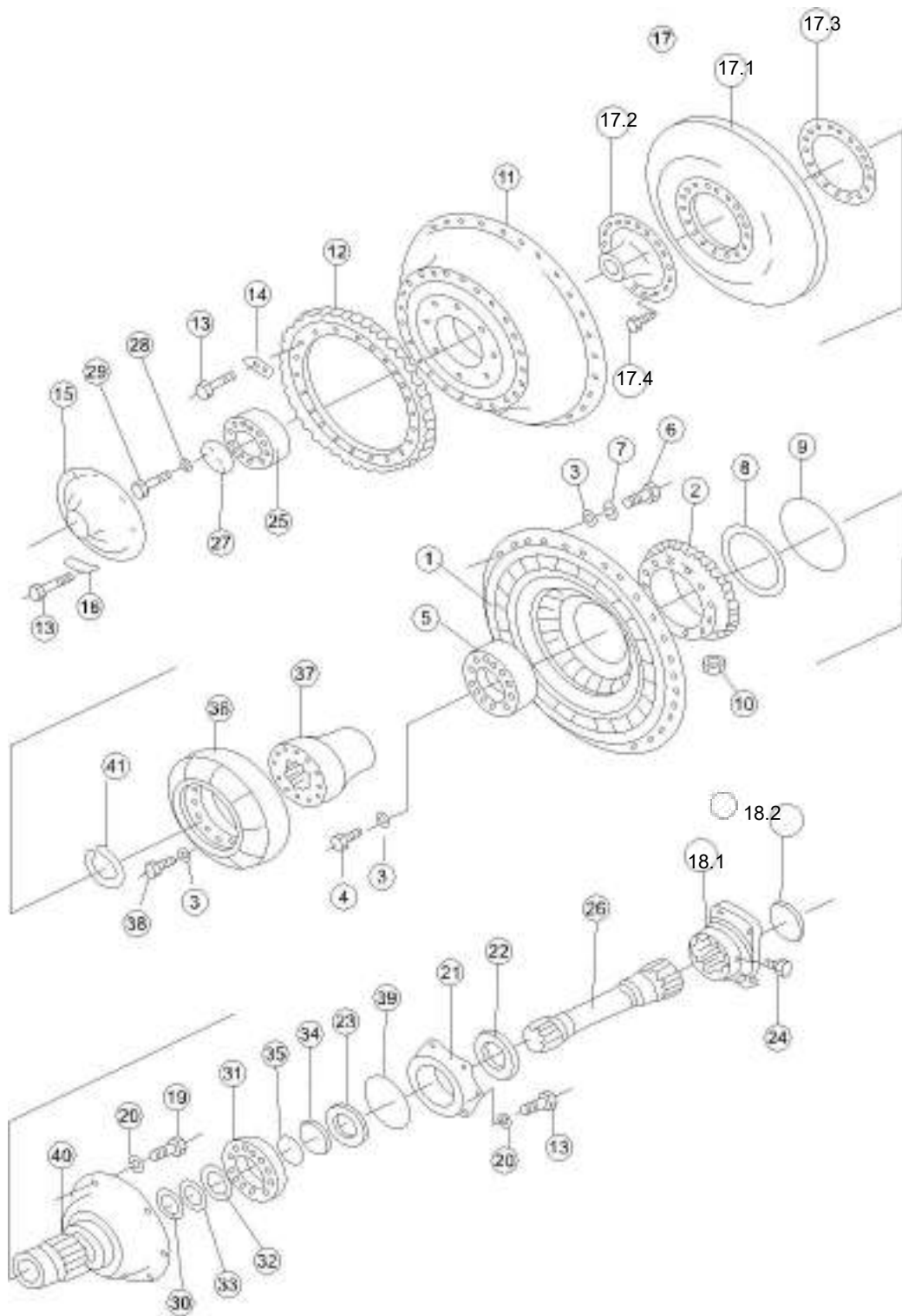

序号 NO.	部件号 PART NO.	零件名称 PART NAME		数量 Q'TY	适用机型 MODEL
0	175-13-21007	变矩器总成	Torque converter ass'y	1	
1	175-13-21124	泵轮	Pump impeller	1	
2	175-13-21141	齿轮	Gear	1	
3	01643-31032	垫圈 10	Washer 10	54	
4	01010-51035	螺栓 M10*35	Bolt M10*35	12	
5	175-13-21160	轴承	Bearing	1	
6	01010-61035	螺栓	Bolt	30	
7	01602-21030	垫圈 10	Washer 10	30	
8	195-13-12711	密封环	Sealing ring	1	
9	07000-65190	O 型圈	O-ring	1	
10	07040-11007	螺塞	Screw plug	2	
11	175-13-21213	罩轮	Cover wheel	1	
12	175-13-21220	齿轮	Gear	1	
13	01010-81230	螺栓 M12*30	Bolt M12*30	38	
14	01643-31232	垫圈 12	Washer 12	24	
15	175-13-21253	定位罩	Positioning cover	1	
16	195-13-11261	锁板	Lock plate	4	
17.40	195-13-11550	铆钉	Rivet	18	
17	175-13-21513	涡轮	Turbine	1	
17.10	175-13-21522	涡轮	Turbine	1	
17.20	175-13-21532	轮毂	Hub	1	
17.30	175-13-21540	板	Plate	1	
18	175-13-21641	联轴节	Shaft coupling	1	
18.10	175-13-21662	联轴节	Shaft coupling	1	
18.20	175-13-11671	盖	Cover	1	
19	01010-51235	螺栓 M12*35	Bolt M12*35	6	
20	01602-21236	垫圈 12	Washer 12	12	
21	175-13-22721	盖	Cover	1	
22	175-13-22730	密封圈	Seal ring	1	
23	07011-00080	骨架油封	Oil seal	1	
24	07020-00613	油杯 M6	Oil cup M6	1	
25	175-13-21240	轴承	Bearing	1	
26	175-13-21654	轴	Shaft	1	
27	175-13-21692	挡圈	Retainer ring	1	
28	175-13-21712	锁紧垫	Lock washer	1	
29	195-13-11810	螺栓	Bolt	2	
30	178-13-11720	密封环	Sealing ring	1	

# 涡轮导向器 TURBINE AND STATOR

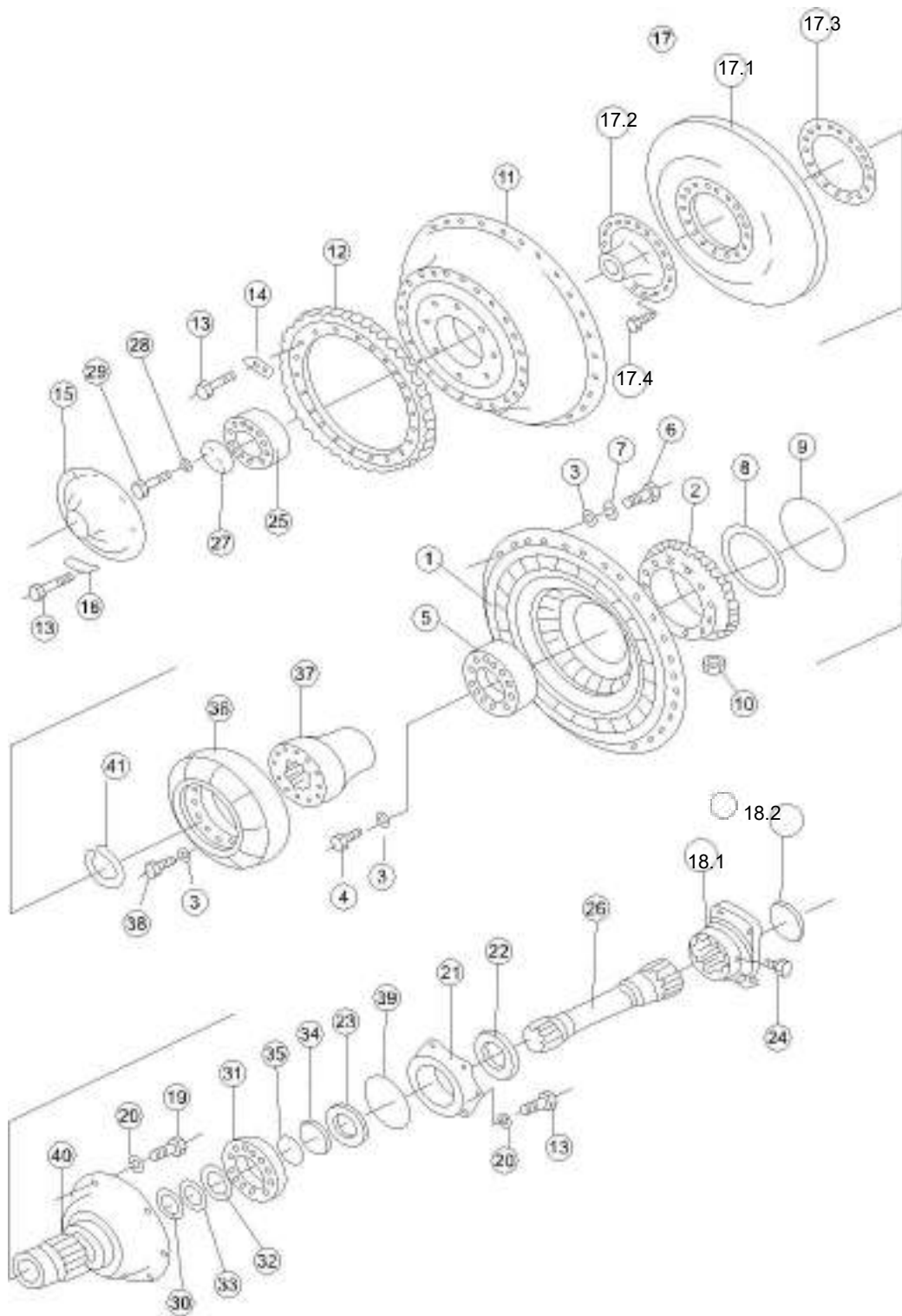

序号 NO.	部件号 PART NO.	零件名称 PART NAME		数量 Q'TY	适用机型 MODEL
31	GB276-6313C4	深沟球轴承	Deep groove ball bearings	1	
32	175-13-21770	垫圈	Washer	1	
33	04064-06525	挡圈	Retainer ring	1	
34	175-13-21750	环座	Ring seat	1	
35	07000-35055	O 型圈	O-ring	1	
36	175-13-22313	导轮	Guide roller	1	
37	175-13-22122	导轮座圈	Ring, Guide	1	
38	01010-51030	螺栓 M10*30	Bolt M10*30	12	
39	07000-65135	O 型圈	O-ring	1	
40	175-13-22524	轴	Shaft	1	
41	04064-08530	挡圈	Retainer ring	1	

变速箱壳  
TORQUE TRANSMISSION CASE

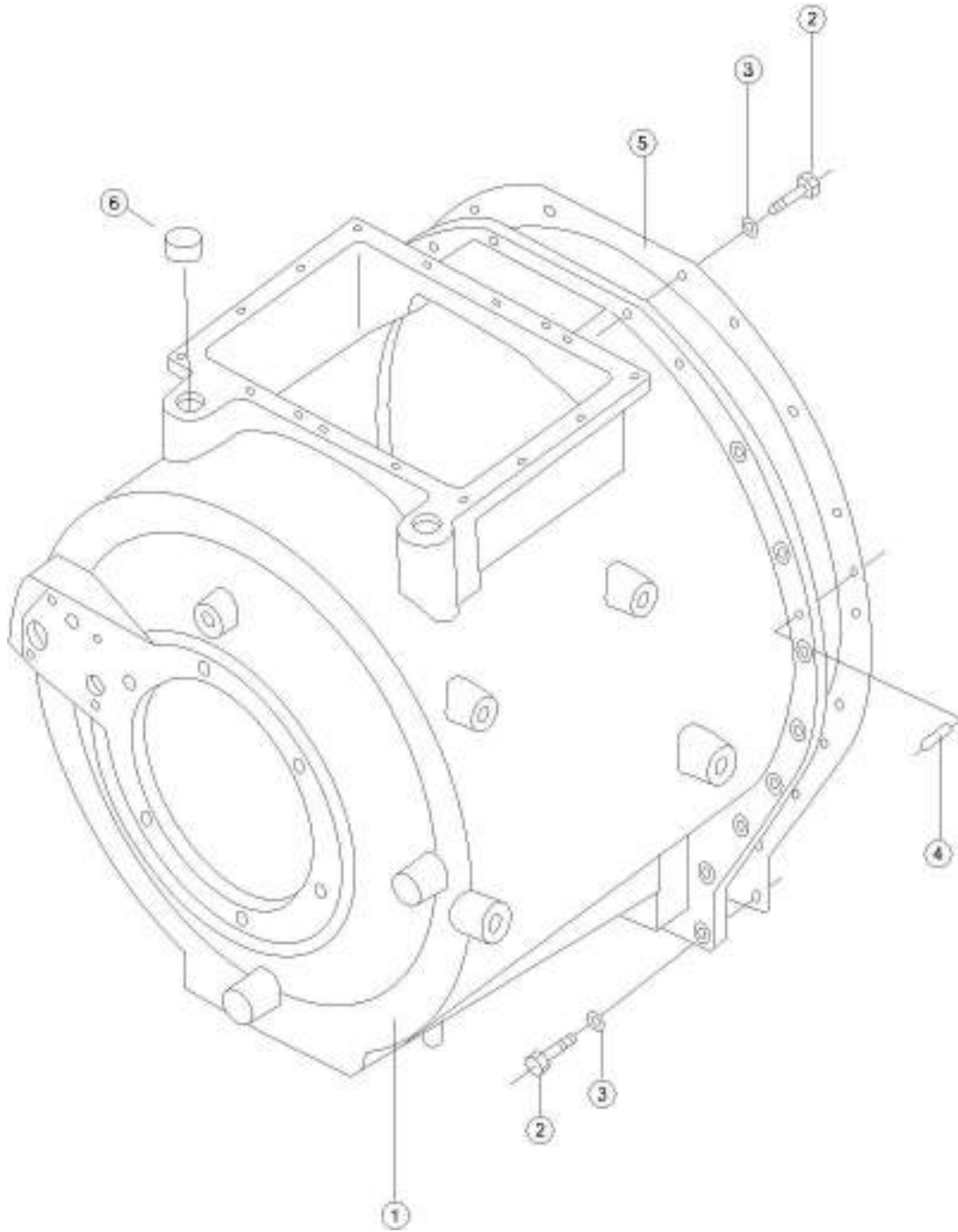

零件图册 | 变矩器和变速箱

序号 NO.	部件号 PART NO.	零件名称 PART NAME		数量 Q'TY	适用机型 MODEL
0	175-15-00226	变速箱	Transmission case	1	
1	175-15-41111	变速箱体	Transmission case body	1	
2	01010-51240	螺栓 M12*40	Bolt M12*40	22	
3	01602-21236	垫圈 12	Washer 12	22	
4	04020-01228	圆柱销	Cylindrical pin	1	
5	175-15-41121	垫片	Shim	1	
6	07048-02216	防尘塞	Plug, Dust	3	

### 变速箱齿轮与轴 (1/2) TRANSMISSION GEAR AND SHAFT (1/2)

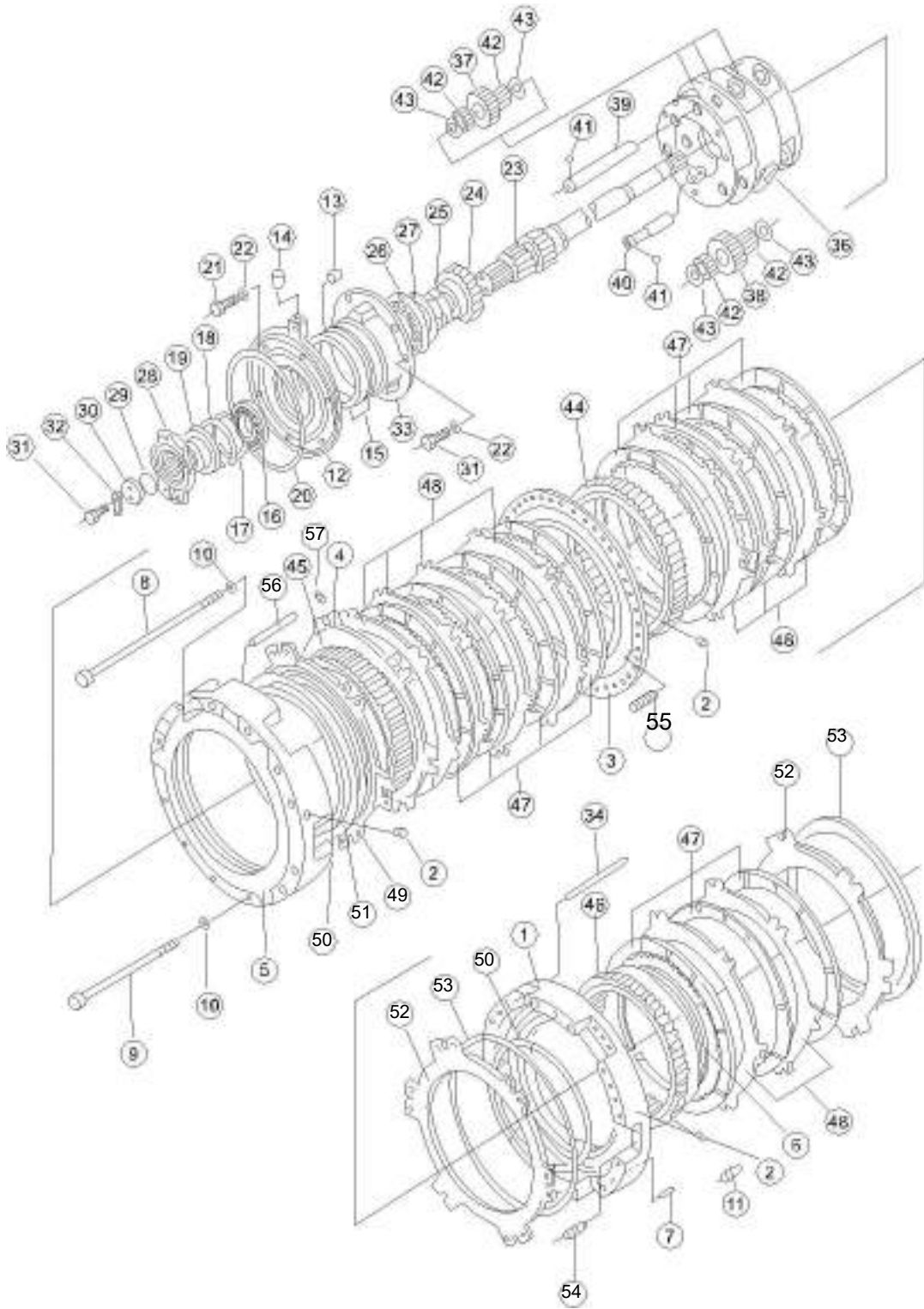

零件图册 | 变矩器和变速箱

序号 NO.	部件号 PART NO.	零件名称 PART NAME	数量 Q'TY	适用机型 MODEL
0	175-15-00226	变速箱 Transmission case	1	
1	175-15-41160	活塞座 Piston seat	1	
2	145-14-11320	螺塞 Screw plug	6	
3	175-15-41172	垫板 Plate	1	
4	175-15-42920	板 Plate	1	
5	175-15-41189	活塞座 Piston seat	1	
6	175-15-42670	卡环 Snap ring	1	
7	04020-01228	圆柱销 Cylindrical pin	4	
8	175-15-41192	螺栓 Bolt	12	
9	175-15-41292	螺栓 Bolt	2	
10	145-14-11570	垫圈 Washer	14	
11	09231-01430	衬套 Bushing	4	
12	175-15-41211	外壳 Casing	1	
13	195-15-11230	螺塞 Screw plug	1	
14	07042-20211	螺塞 Screw plug	1	
15	07018-11805	密封环 Sealing ring	2	
16	GB276-6016	深沟球轴承 Deep groove ball bearings	1	
17	195-15-11240	衬垫 Gasket	1	
18	170-14-22140	弹性挡环 Retainer	1	
19	07012-50100	骨架油封 Oil seal	1	
20	07000-15290	O 形圈 O-ring	1	
21	01010-51235	螺栓 M12*35 Bolt M12*35	6	
22	01602-21236	垫圈 12 Washer 12	12	
23	175-15-42112	轴 Shaft	1	
24	175-15-42122	齿轮 Gear	1	
25	195-15-12141	衬垫 Gasket	1	
26	GB276-61924	深沟球轴承 Deep groove ball bearings	1	
27	130-09-16780	卡环 Snap ring	2	
28	175-15-42151	联轴节 Shaft coupling	1	
29	07000-05055	O 形圈 O-ring	1	
30	175-15-12160	托板 Plate	1	
31	01010-51230	螺栓 M12*30 Bolt M12*30	8	
32	04081-05512	垫片 Shim	1	
33	175-15-42311	轴承座 Bearing support	1	
34	175-15-12780	销 Pin	6	
36	175-15-42322	行星架 Carrier	1	
37	175-15-42451	齿轮 Gear	9	

### 变速箱齿轮与轴 (1/2) TRANSMISSION GEAR AND SHAFT (1/2)

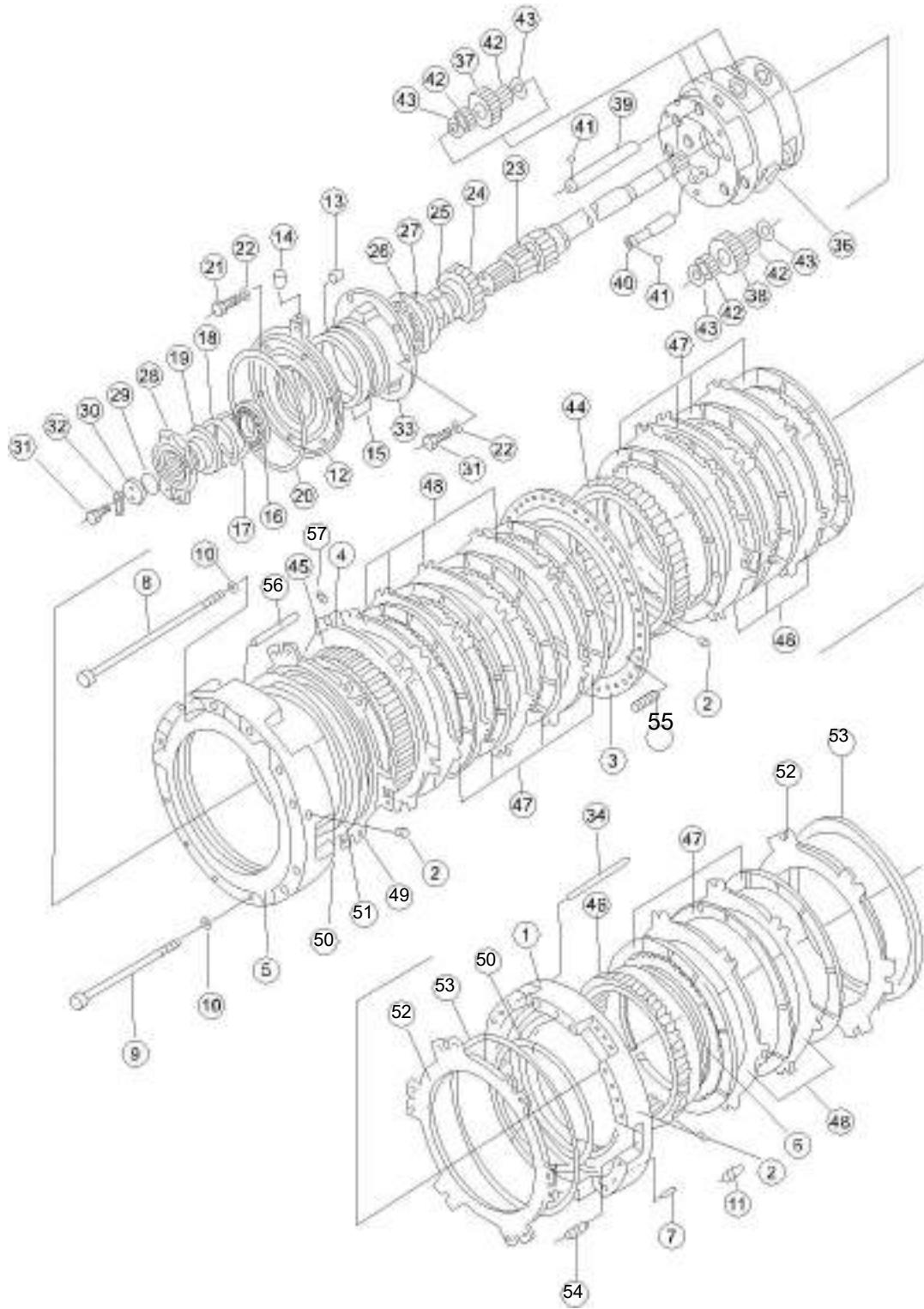

序号 NO.	部件号 PART NO.	零件名称 PART NAME	数量 Q'TY	适用机型 MODEL
38	175-15-42471	齿轮 Gear	3	
39	175-15-42512	轴 Shaft	3	
40	175-15-42532	轴 Shaft	3	
41	04260-00635	钢球 Steel ball	6	
42	09232-05125	轴承 Bearing	24	
43	09233-05125	止推垫圈 Thrust washer	24	
44	175-15-42610	齿圈 Gear ring	1	
45	175-15-42620	齿圈 Gear ring	1	
46	175-15-42632	齿圈 Gear ring	1	
47	175-15-12715	摩擦片 Friction disk	11	
48	175-15-42721	垫板 Plate	9	
49	175-15-42860	活塞 Piston	1	
50	175-15-12750	密封环 Sealing ring	4	
51	175-15-12820	密封环 Sealing ring	1	
52	175-15-42870	活塞 Piston	2	
53	195-15-12740	密封环 Sealing ring	2	
54	175-15-42780	弹簧 Spring	12	
55	145-14-12810	弹簧 Spring	12	
56	145-14-12760	销 Pin	6	
57	175-15-42880	弹簧 Spring	78	

### 变速箱齿轮与轴 (2/2) TRANSMISSION GEAR AND SHAFT (2/2)

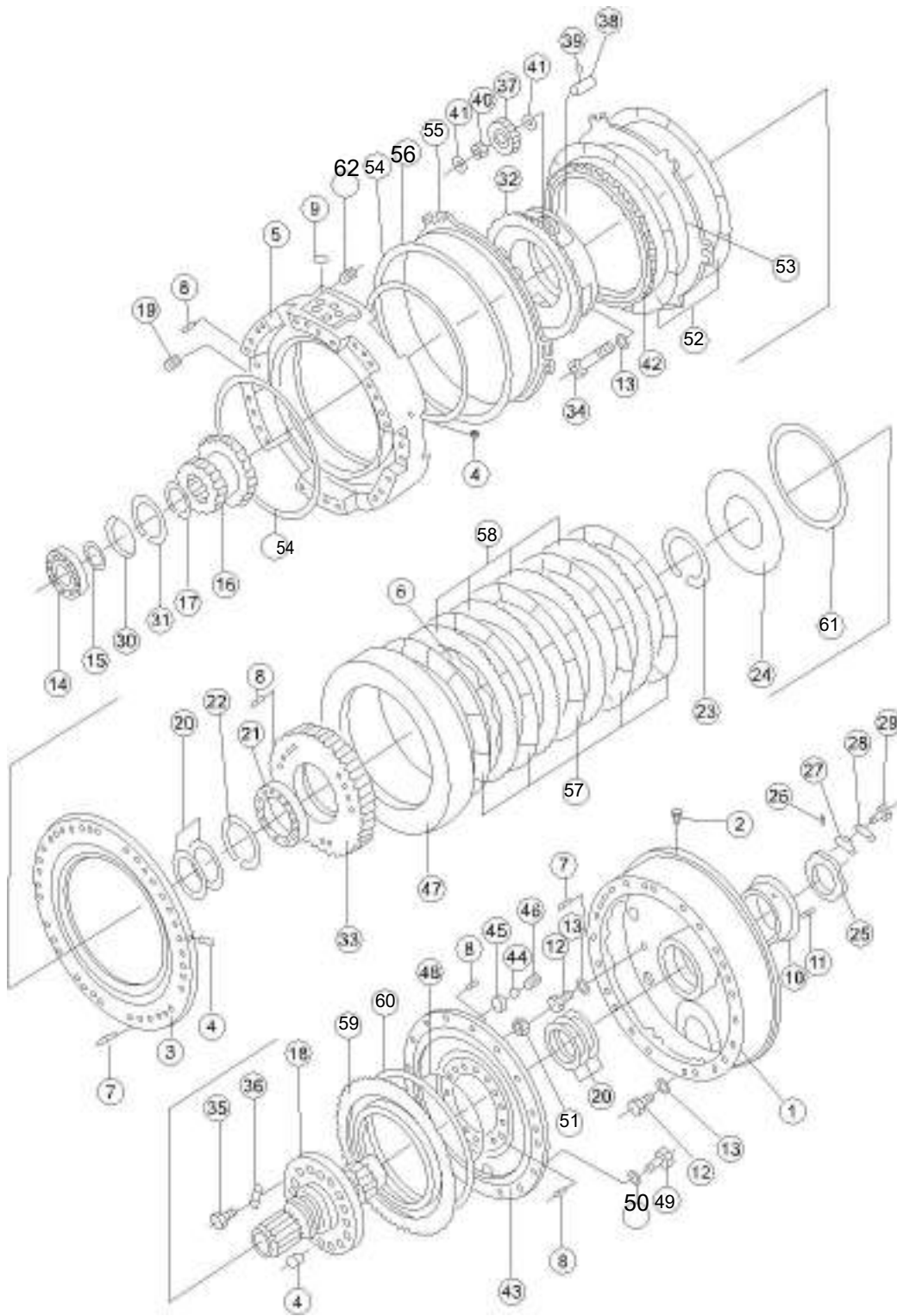

零件图册 | 变矩器和变速箱

序号 NO.	部件号 PART NO.	零件名称 PART NAME	数量 Q'TY	适用机型 MODEL
0	175-15-00226	变速箱 Transmission case	1	
1	178-15-11130	壳 Housing	1	
2	234-15-12780	螺钉 Screw	3	
3	175-15-41140	垫板 Plate	1	
4	145-14-11320	螺塞 Screw plug	12	
5	175-15-41150	活塞室 Piston cabin	1	
6	175-15-42890	波状弹簧 Spring, Waveform	5	
7	175-15-31210	定位销 Pin, Dowel	4	
8	04020-01228	圆柱销 Cylindrical pin	12	
9	07000-73022	O 形圈 O-ring	5	
10	175-15-41310	套环 Collar	1	
11	04020-00616	圆柱销 Cylindrical pin	1	
12	01010-51435	螺栓 M14*35 Bolt M14*35	2	
13	01602-01442	垫圈 14 Washer 14	8	
14	GB283-NU212C4	圆柱滚子轴承 Cylindrical roller bearing	1	
15	04064-06020	挡圈 Retainer ring	1	
16	175-15-42131	齿轮 Gear	1	
17	04064-08530	挡圈 Retainer ring	1	
18	175-15-42213	轴 Shaft	1	
19	145-14-12790	弹簧 Spring	24	
20	175-15-42850	密封环 Sealing ring	5	
21	GB276-61924	深沟球轴承 Deep groove ball bearings	1	
22	130-09-16780	卡环 Snap ring	2	
23	04070-00130	挡圈 Retainer ring	1	
24	175-15-42180	碟形弹簧 Disk-shaped spring	1	
25	234-21-12180	螺帽 Nut	1	
26	175-15-42220	销 Pin	1	
27	234-21-12190	垫片 Shim	1	
28	234-21-12210	锁片 Locking plate	1	
29	01010-50816	螺栓 M8*16 Bolt M8*16	2	
30	175-15-42340	挡油板 Oil baffle plate	1	
31	130-09-15740	卡环 Snap ring	1	
32	175-15-42364	行星架 Carrier	1	
33	175-15-42571	齿轮 ( 外鼓 ) Gear (Outer drum)	1	
34	01010-51490	螺栓 M14*90 Bolt M14*90	6	
35	175-15-42230	铰制孔螺栓 Bolt, Hinge	16	
36	175-15-42240	锁片 Locking plate	8	

### 变速箱齿轮与轴 (2/2) TRANSMISSION GEAR AND SHAFT (2/2)

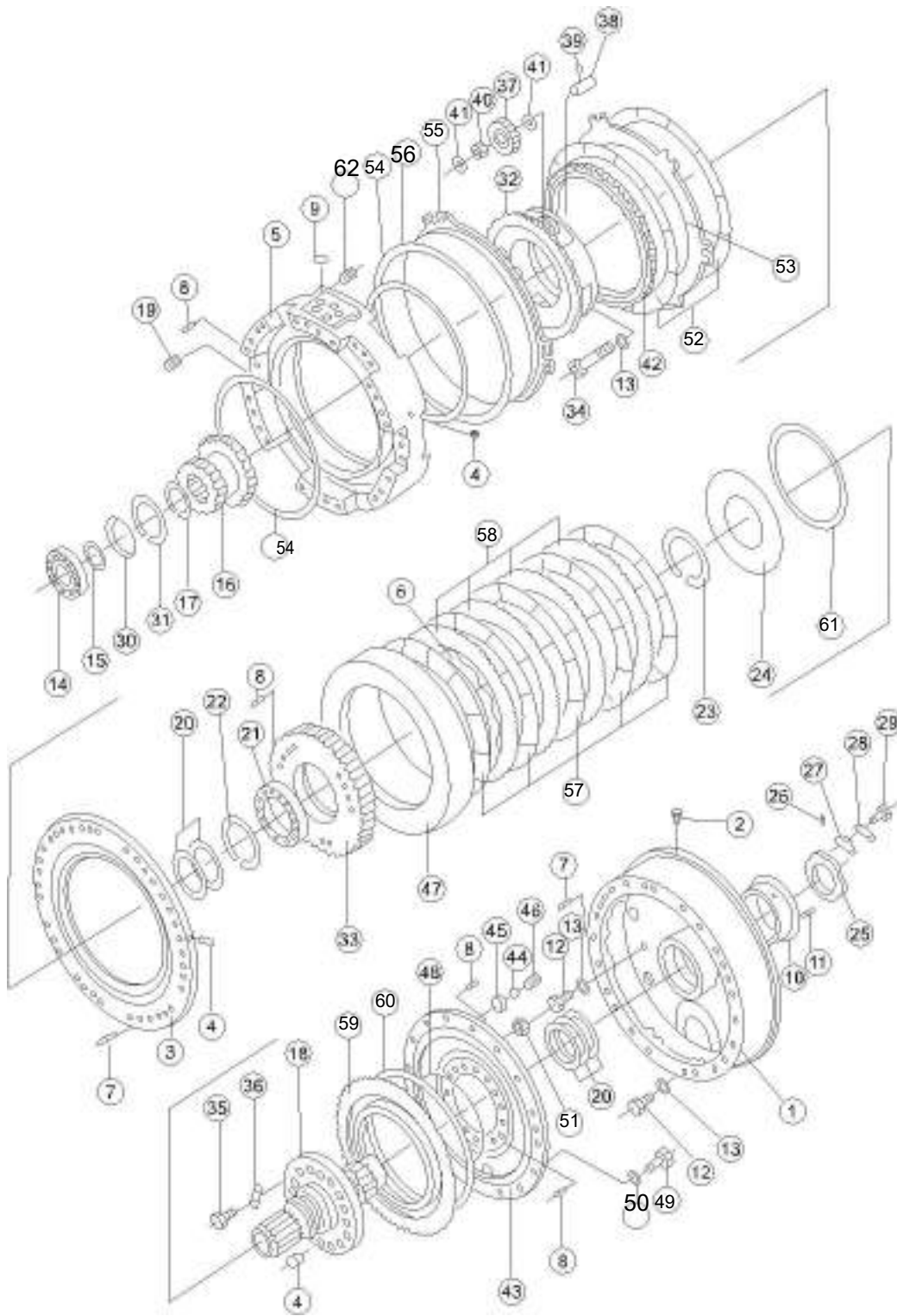

序号 NO.	部件号 PART NO.	零件名称 PART NAME	数量 Q'TY	适用机型 MODEL
37	175-15-42491	齿轮 Gear	3	
38	175-15-42552	轴 Shaft	3	
39	04260-00635	钢球 Steel ball	3	
40	09232-03838	轴承 Bearing	3	
41	09233-03820	止推垫圈 Thrust washer	6	
42	175-15-42650	齿圈 Gear ring	1	
43	175-15-42412	油缸体 Oil cylinder body	1	
44	04260-00952	钢球 Steel ball	2	
45	175-15-42971	阀套 Valve cover	2	
46	234-15-12790	螺塞 Screw plug	2	
47	175-15-42421	外鼓 Outer drum	1	
48	175-15-42430	O形圈 O-ring	1	
49	01010-51230	螺栓 M12*30 Bolt M12*30	12	
50	01602-21236	垫圈 12 Washer 12	12	
51	01582-01210	螺母 M12*1.5 Nut M12*1.5	16	
52	175-15-12715	摩擦片 Friction disk	13	
53	175-15-42721	垫板 Plate	1	
54	175-15-12750	密封环 Sealing ring	2	
55	175-15-42870	活塞 Piston	1	
56	195-15-12740	密封环 Sealing ring	1	
57	154-15-12715	摩擦片 Friction disk	5	
58	281-15-12720	齿片 Tooth piece	4	
59	175-15-42740	活塞 Piston	1	
60	175-15-42750	密封环 Sealing ring	1	
61	234-15-11220	密封环 Sealing ring	1	

# 变速箱 TRANSMISSION CASE

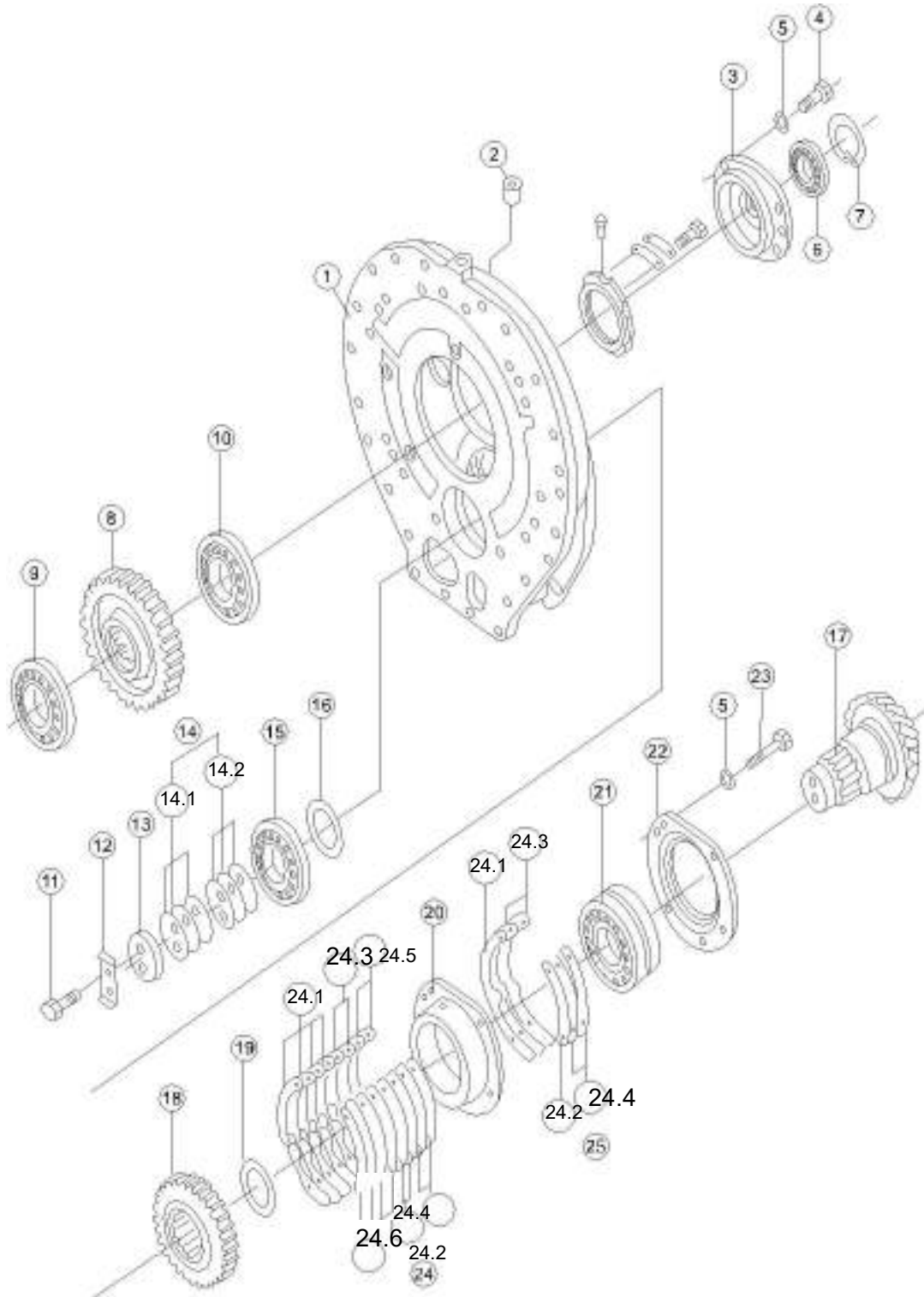

零件图册 | 变矩器和变速箱

序号 NO.	部件号 PART NO.	零件名称 PART NAME		数量 Q'TY	适用机型 MODEL
0	175-15-00226	变速箱	Transmission case	1	
1	175-15-43116	后壳体	Housing body (Rear)	1	
2	07042-20211	螺塞	Screw plug	1	
3	175-15-43152	壳体	Housing body	1	
4	01010-51240	螺栓 M12*40	Bolt M12*40	5	
5	01602-21236	垫圈 12	Washer 12	9	
6	GB288-22211C	调心滚子轴承	Spherical Roller Bearing	1	
7	04065-01030	挡圈	Retainer ring	1	
8	175-15-43212	齿轮	Gear	1	
9	175-15-49340	轴承	Bearing	1	
10	175-15-43270	轴承	Bearing	1	
11	01010-51435	螺栓 M14*35	Bolt M14*35	2	
12	04081-07012	垫片	Shim	2	
13	178-15-13620	挡板	Plate	1	
14.1	178-15-13520	垫片	Shim	3	
14.2	178-15-13540	垫片	Shim	3	
14	178-15-00121	垫片总成	Shim ass'y	1	
15	178-15-19330	轴承	Bearing	1	
16	178-15-13370	隔环	Ring	1	
17	178-15-13240	小齿轮轴	Pinion shaft	1	
18	175-15-43232	齿轮	Gear	1	
19	178-15-13360	隔环	Ring	1	
20	178-15-13260	轴承座	Bearing support	1	
21	178-15-19350	轴承	Bearing	1	
22	178-15-13140	盖	Cover	1	
23	01010-51250	螺栓 M12*50	Bolt M12*50	4	
24	175-15-05011	垫片总成	Shim ass'y	1	
24.1	175-15-13311	垫片	Shim	4	
24.2	175-15-13331	垫片	Shim	4	
24.3	175-15-13470	垫片	Shim	4	
24.4	175-15-13480	垫片	Shim	4	
24.5	175-15-13380	垫片	Shim	2	
24.6	175-15-13390	垫片	Shim	2	
25	175-15-05051	垫片总成	Shim ass'y	1	

# 变速阀 TRANSMISSION CONTROL VALVE

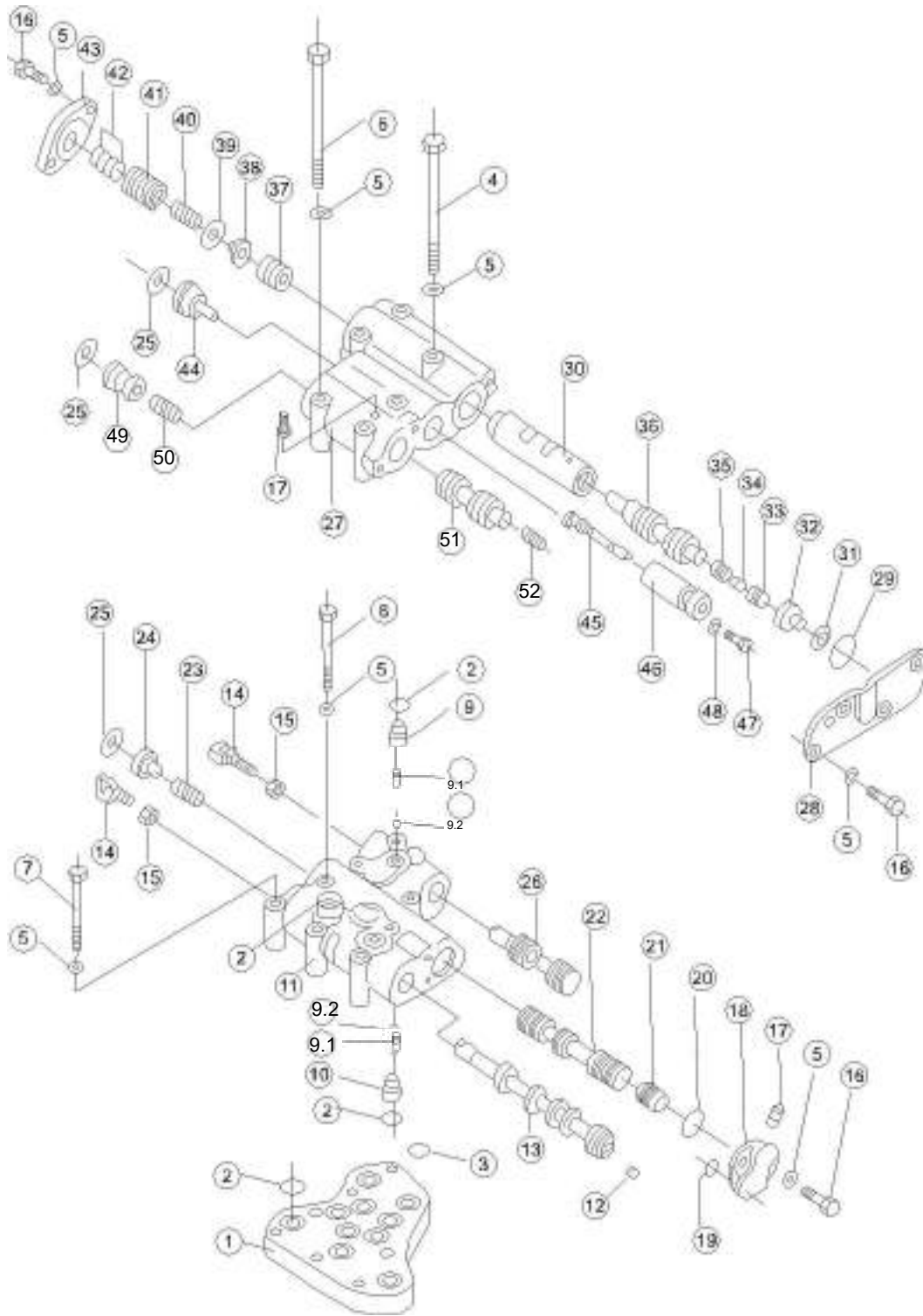

序号 NO.	部件号 PART NO.	零件名称 PART NAME		数量 Q'TY	适用机型 MODEL
0	175-15-35002	变速阀总成	Transmission control valve ass'y	1	
1	175-15-45110	阀体	Valve body	1	
2	07000-63022	O型圈	O-ring	12	
3	07000-63025	O型圈	O-ring	3	
4	175-15-45180	螺栓	Bolt	3	
5	01602-21030	垫圈 10	Washer 10	16	
6	175-15-45170	螺栓	Bolt	3	
7	175-15-45160	螺栓	Bolt	1	
8	01010-51075	螺栓 M10*75	Bolt M10*75	1	
9.2	04260-00952	钢球	Steel ball	2	
9	195-15-15671	定位装置	Device, Locating	1	
9.1	195-15-15680	弹簧	Spring	2	
10	175-15-45260	定位装置	Device, Locating	1	
11	175-15-45212	阀体	Valve body	1	
12	144-15-25210	螺塞	Screw plug	1	
13	175-15-45231	滑栓	Slide bolt	1	
14	09363-01053	叉	York	2	
15	01580-11008	螺母 M10	Nut M10	2	
16	01010-51025	螺栓 M10*25	Bolt M10*25	8	
17	07042-00108	螺塞	Screw plug	2	
18	175-15-45471	盖	Cover	1	
19	07000-62016	O形圈	O-ring	1	
20	07000-63032	O型圈	O-ring	1	
21	175-15-35430	柱塞	Plunger	1	
22	175-15-45420	滑阀	Slide valve	1	
23	195-15-15440	弹簧	Spring	1	
24	175-15-45450	挡块	Block	1	
25	04065-03515	挡圈	Retainer ring	3	
26	175-15-45220	阀柱	Valve stem	1	
27	155-15-15410	阀体	Valve body	1	
28	155-15-15850	盖	Cover	1	
29	07000-63040	O型圈	O-ring	1	
30	145-14-43381	滑阀	Slide valve	1	
31	130-09-15170	卡环	Snap ring	1	
32	145-14-23180	挡块	Block	1	
33	175-15-15550	阀	Valve	1	

# 变速阀 TRANSMISSION CONTROL VALVE

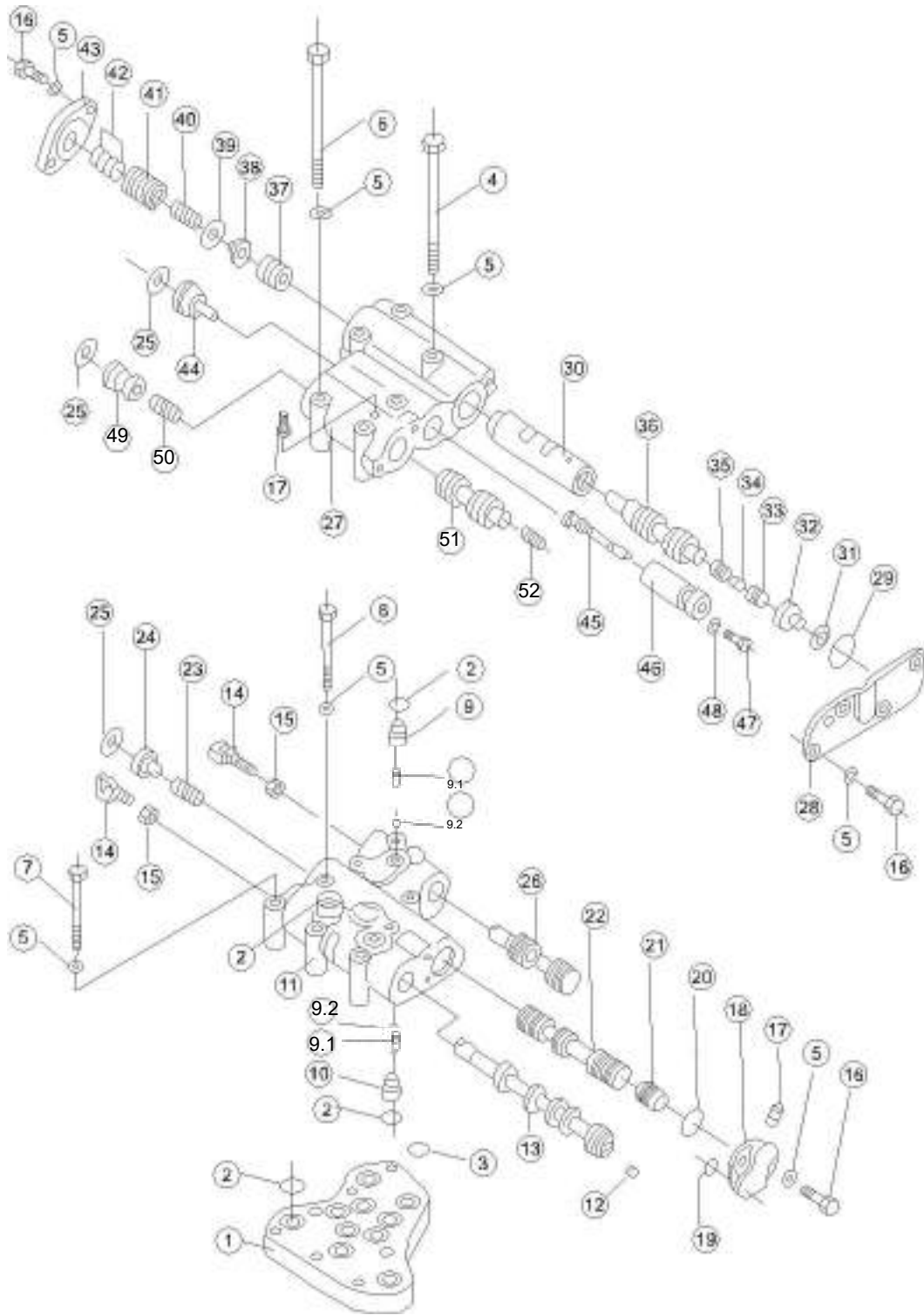

序号 NO.	部件号 PART NO.	零件名称 PART NAME	数量 Q'TY	适用机型 MODEL
34	180-14-25560	弹簧 Spring	1	
35	175-15-15540	阀 Valve	1	
36	145-14-43331	阀 Valve	1	
37	154-15-33430	弹簧 Spring	1	
38	145-14-43340	座 Seat	1	
39	145-14-33450	垫圈 Washer	1	
40	145-14-33420	弹簧 Spring	1	
41	145-14-33351	弹簧 Spring	1	
42	145-14-43370	垫 Pad	3	
43	144-15-25330	盖 Cover	1	
44	155-15-15360	挡块 Block	1	
45	154-15-15320	阀杆 Valve stem	1	
46	155-15-15351	轴套 Sleeve	1	
47	155-15-15370	螺栓 Bolt	1	
48	01602-20619	垫圈 6 Washer 6	1	
49	175-15-45390	导座 Seat, Guide	1	
50	234-15-15230	弹簧 Spring	1	
51	175-15-45380	阀 Valve	1	
52	145-14-23720	柱塞 Plunger	1	

### 盖与阀控制杆 COVER AND VALVE CONTROL LEVER

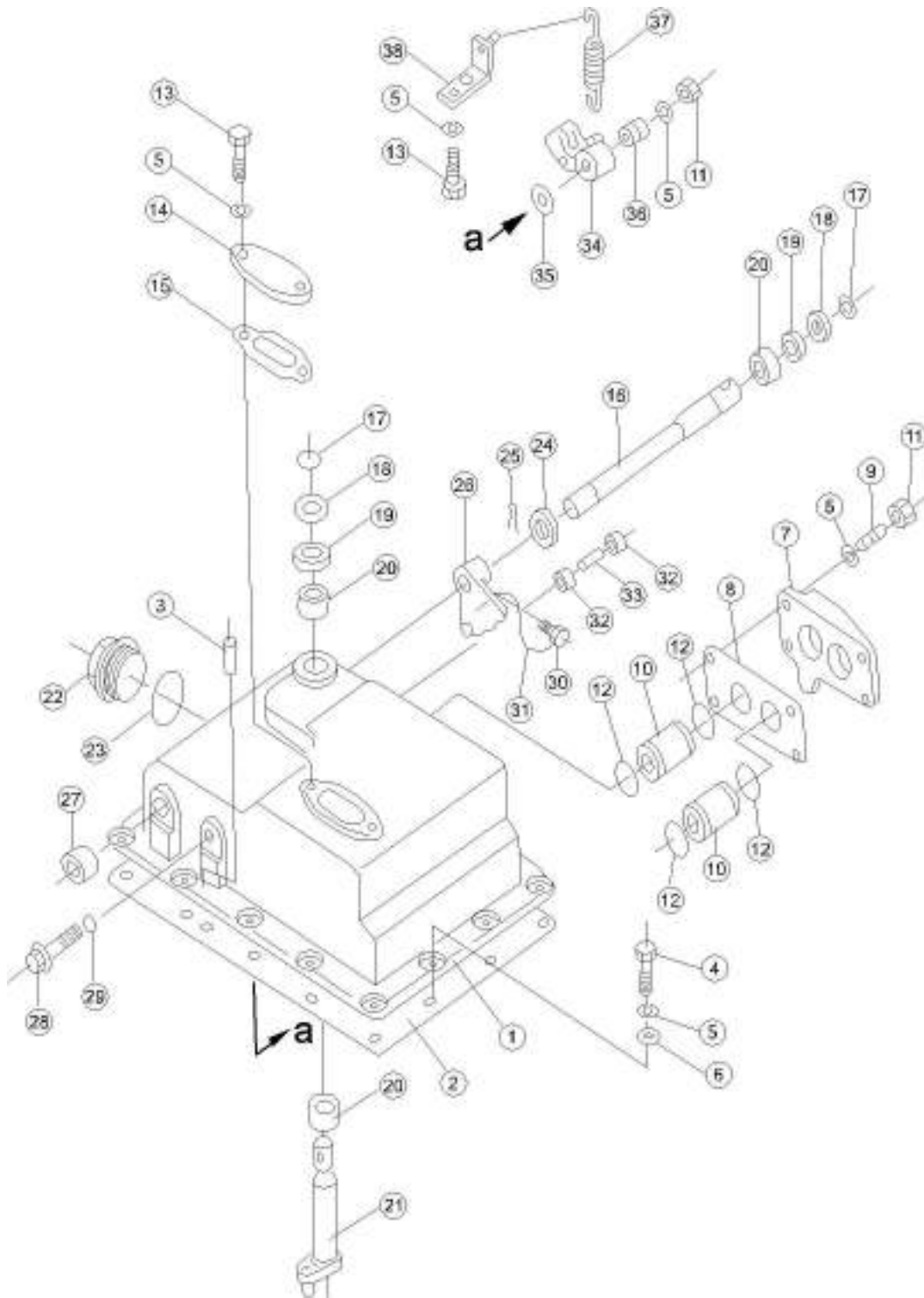

序号 NO.	部件号 PART NO.	零件名称 PART NAME		数量 Q'TY	适用机型 MODEL
0	175-15-35002	变速阀总成	Transmission control valve ass'y	1	
1	175-15-45510	盖	Cover	1	
2	175-15-45520	垫	Pad	1	
3	04020-00820	圆柱销	Cylindrical pin	2	
4	01010-51025	螺栓 M10*25	Bolt M10*25	14	
5	01602-21030	垫圈 10	Washer 10	23	
6	01640-21016	垫圈 10	Washer 10	14	
7	175-15-45530	盖	Cover	1	
8	175-15-45540	垫	Pad	1	
9	01124-51025	螺柱	Stud	4	
10	175-15-45550	套	Sleeve	2	
11	01580-11008	螺母 M10	Nut M10	5	
12	07000-63028	O型圈	O-ring	4	
13	01010-51020	螺栓 M10*20	Bolt M10*20	4	
14	175-15-45750	板	Plate	1	
15	175-15-45760	垫	Pad	1	
16	175-15-45610	轴	Shaft	1	
17	04064-01812	挡圈	Retainer ring	2	
18	175-15-45570	垫圈	Washer	2	
19	144-15-29110	油封	Oil seal	2	
20	06120-02016	滚针轴承	Needle Roller Bearing	3	
21	175-15-45560	杠杆	Lever	1	
22	07040-15223	螺塞	Screw plug	1	
23	07002-05234	O形圈	O-ring	1	
24	175-15-45620	挡环	Retaining ring	1	
25	04050-03040	开口销	Cotter pin	1	
26	175-15-45630	杠杆	Lever	1	
27	06121-02016	轴承	Bearing	1	
28	175-15-45650	螺栓	Bolt	1	
29	07002-01223	O形圈	O-ring	1	
30	125-15-11530	螺栓	Bolt	1	
31	04059-01010	铁丝	Iron wire	1	
32	144-15-29120	轴承	Bearing	2	
33	144-15-25690	滚柱	Roller	1	
34	175-15-45690	杠杆	Lever	1	
35	175-15-45660	垫圈	Washer	2	
36	175-15-45670	套筒	Sleeve	1	
37	175-15-45710	弹簧	Spring	1	
38	175-15-45780	托架	Bracket	1	

# 润滑阀 LUBRICATING VALVE

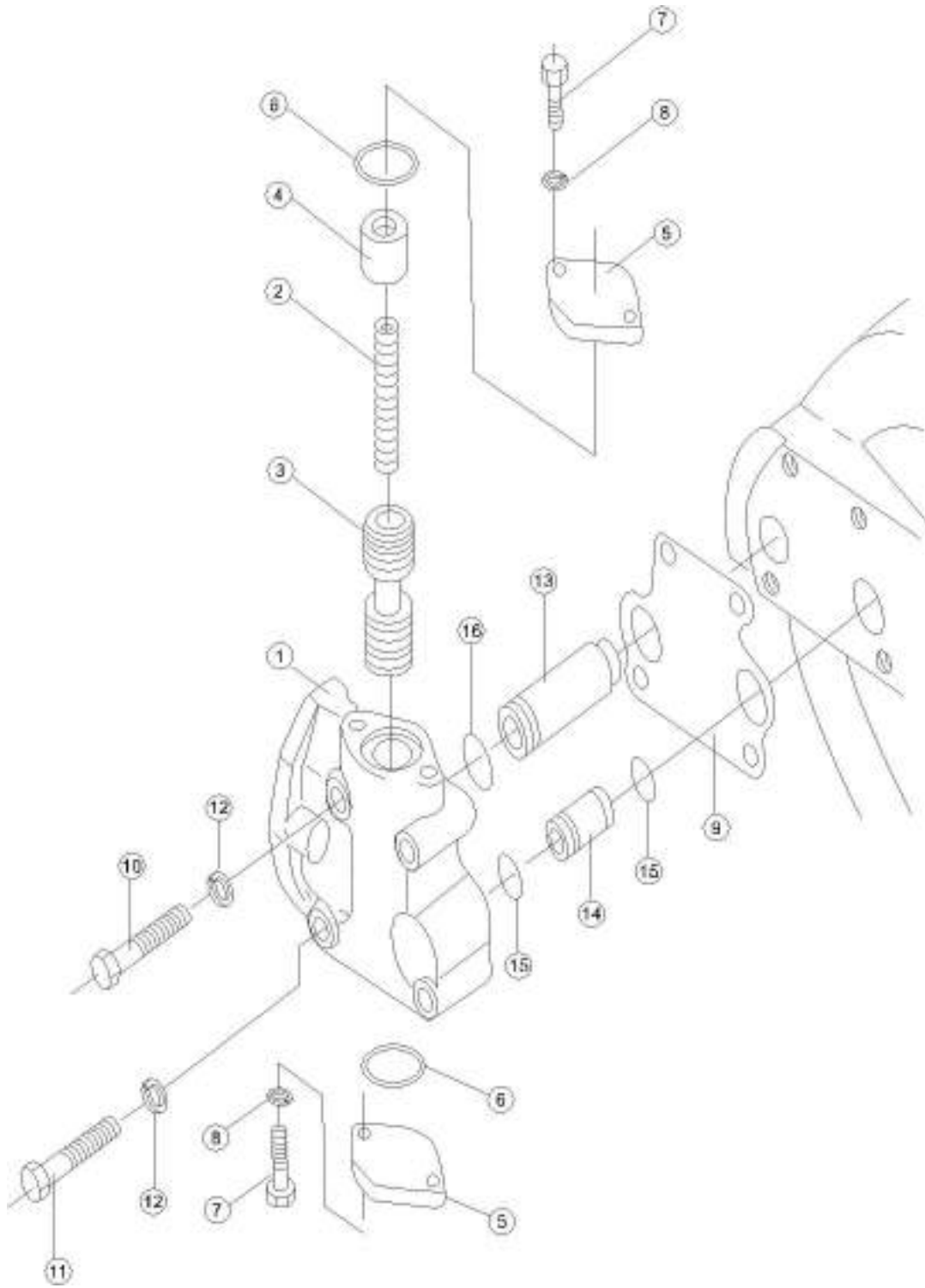

序号 NO.	部件号 PART NO.	零件名称 PART NAME		数量 Q'TY	适用机型 MODEL
1	175-15-14110	阀体	Valve body	1	
2	175-15-14120	弹簧	Spring	1	
3	175-15-14130	阀	Valve	1	
4	175-15-14141	导向套	Sleeve, Guide	1	
5	175-15-14150	盖	Cover	2	
6	07000-63032	O型圈	O-ring	2	
7	01010-50835	螺栓 M8*35	Bolt M8*35	4	
8	01602-20825	垫圈 8	Washer 8	4	
9	175-15-14161	密封垫	Gasket	1	
10	01010-51055	螺栓 M10*55	Bolt M10*55	2	
11	01010-51065	螺栓 M10*65	Bolt M10*65	2	
12	01602-21030	垫圈 10	Washer 10	4	
13	175-15-44190	套管	Sleeve	1	
14	175-15-44180	套筒	Sleeve	1	
15	07000-72018	O形圈	O-ring	2	
16	07000-63022	O型圈	O-ring	1	

### 变速操纵杆 (1/2) GEAR SHIFT LEVER (1/2)

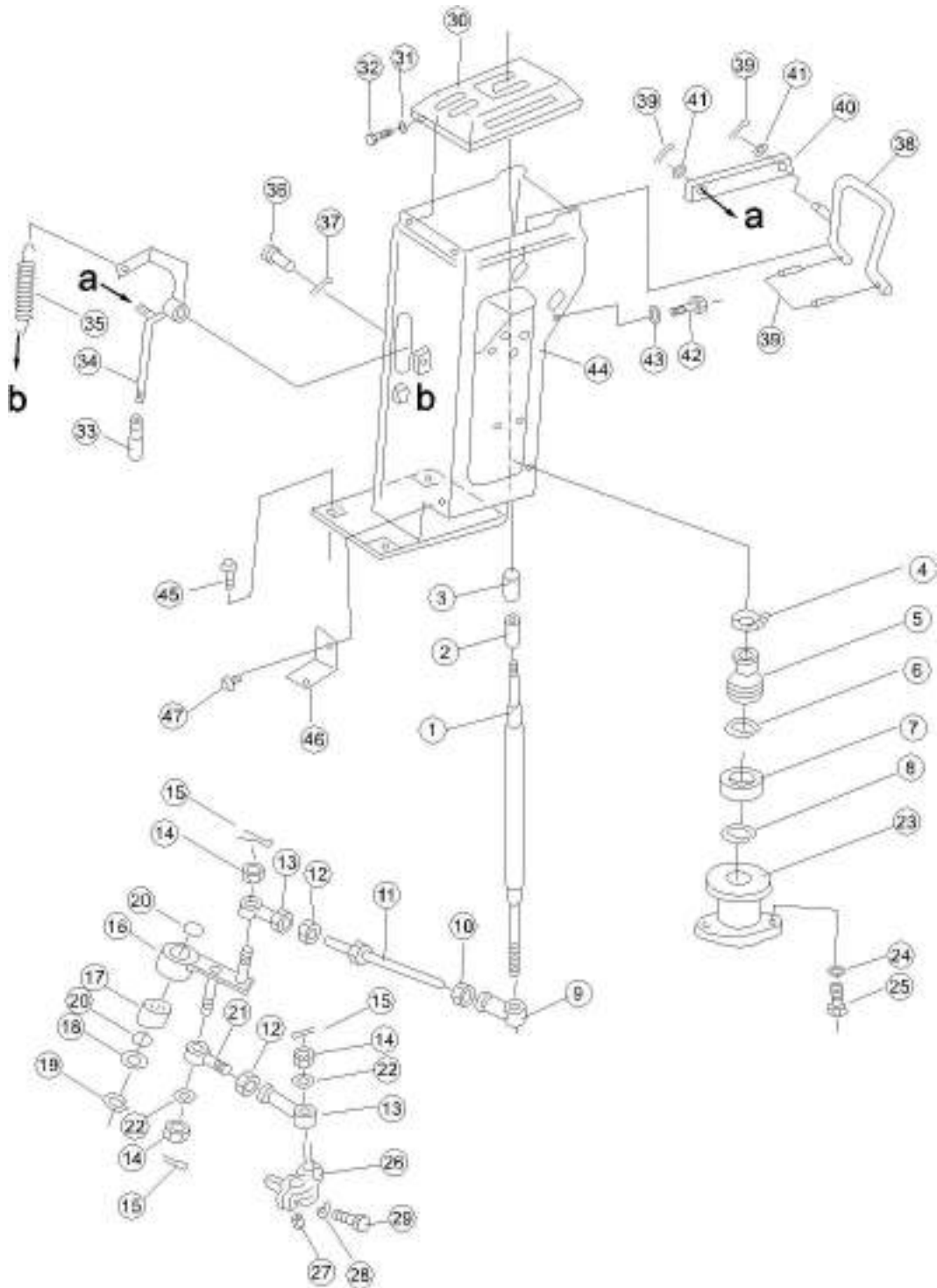

序号 NO.	部件号 PART NO.	零件名称 PART NAME	数量 Q'TY	适用机型 MODEL
1	175-43-54141	杆 Lever	1	
2	09361-01460	衬套 Bushing	1	
3	09304-01240	手柄 Handle	1	
4	07281-00359	喉箍 Hose Clamp	1	
5	175-43-54230	伸缩软管 Flexible hose	1	
6	04065-03012	挡圈 Retainer ring	1	
7	195-43-25310	衬套 Bushing	1	
8	04064-01710	挡圈 Retainer ring	1	
9	04250-61056	关节轴承 Joint bearing	1	
10	01508-41006	螺母 M10*1.25 左 Nut (L.H.) M10*1.25	1	
11	04248-31044	杆 Lever	1	
12	01582-11008	螺母 M10*1.25 Nut M10*1.25	2	
13	04250-41056	关节轴承 Joint bearing	2	
14	01593-31008	螺母 M10*1.25 Nut M10*1.25	3	
15	04050-12018	开口销 Cotter pin	3	
16	175-43-42750	摇臂 Rock arm	1	
17	GB290-HK2016	冲压外圈滚针轴承 Needle roller bearing	1	
18	01640-22032	垫圈 20 Washer 20	1	
19	04064-02012	挡圈 Retainer ring	1	
20	06122-02004	防尘密封圈 Ring, Dust	2	
21	04252-01061	关节轴承 Joint bearing	1	
22	04254-11032	垫圈 Washer	2	
23	195-43-25290	支座 Bracket	1	
24	01643-31032	垫圈 10 Washer 10	2	
25	01010-51025	螺栓 M10*25 Bolt M10*25	2	
26	175-43-41241	支杆 Support bar	1	
27	04010-10516	半圆键 Woodruff Key	1	
28	01602-20825	垫圈 8 Washer 8	1	
29	01010-50830	螺栓 M8*30 Bolt M8*30	1	
30	175-43-38262	上板 Upper plate	1	
31	01643-30823	垫圈 8 Washer 8	4	
32	01220-40816	螺钉 M8*16 Screw M8*16	4	
33	09305-00800	手柄 Handle	1	
34	175-43-41252	摇臂 Rock arm	1	
35	175-43-38270	弹簧 Spring	1	
36	04205-11658	销轴 Pin shaft	1	
37	04050-14026	开口销 Cotter pin	1	

### 变速操纵杆 (1/2) GEAR SHIFT LEVER (1/2)

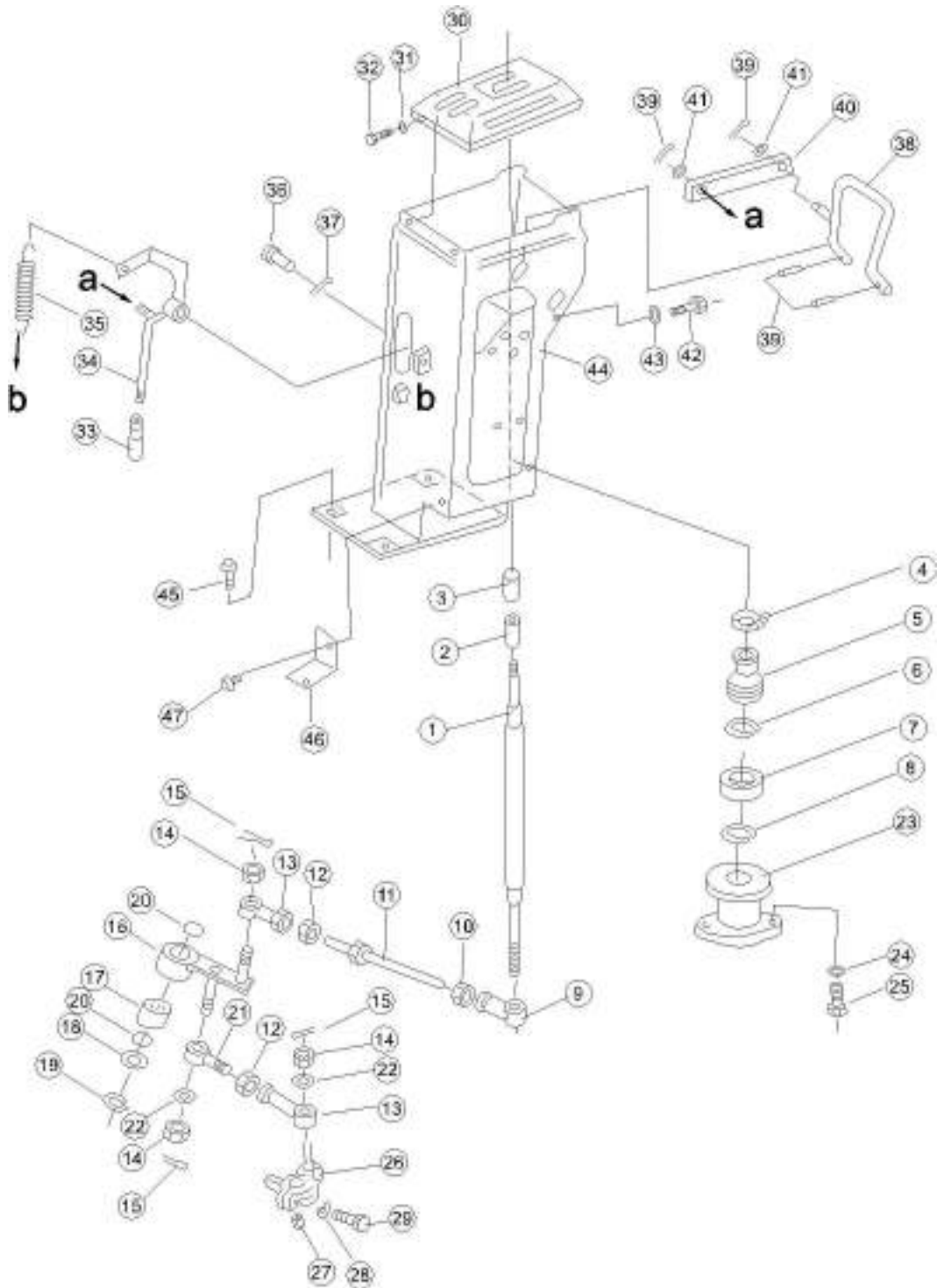

零件图册 | 变矩器和变速箱

序号 NO.	部件号 PART NO.	零件名称 PART NAME		数量 Q'TY	适用机型 MODEL
38	175-43-54191	限位杆	Limit lever	1	
39	04050-11610	开口销	Cotter pin	4	
40	175-43-54211	杆	Lever	1	
41	01640-20610	垫圈 6	Washer 6	2	
42	01010-51225	螺栓 M12*25	Bolt M12*25	4	
43	01643-31232	垫圈 12	Washer 12	4	
44	175-43-41115	罩	Cover	1	
45	195-54-26230	螺钉	Screw	1	
46	175-43-41863	盖板	Cover plate	1	
47	195-54-26210	螺钉	Screw	2	

### 变速操纵杆 (2/2) GEAR SHIFT LEVER (2/2)

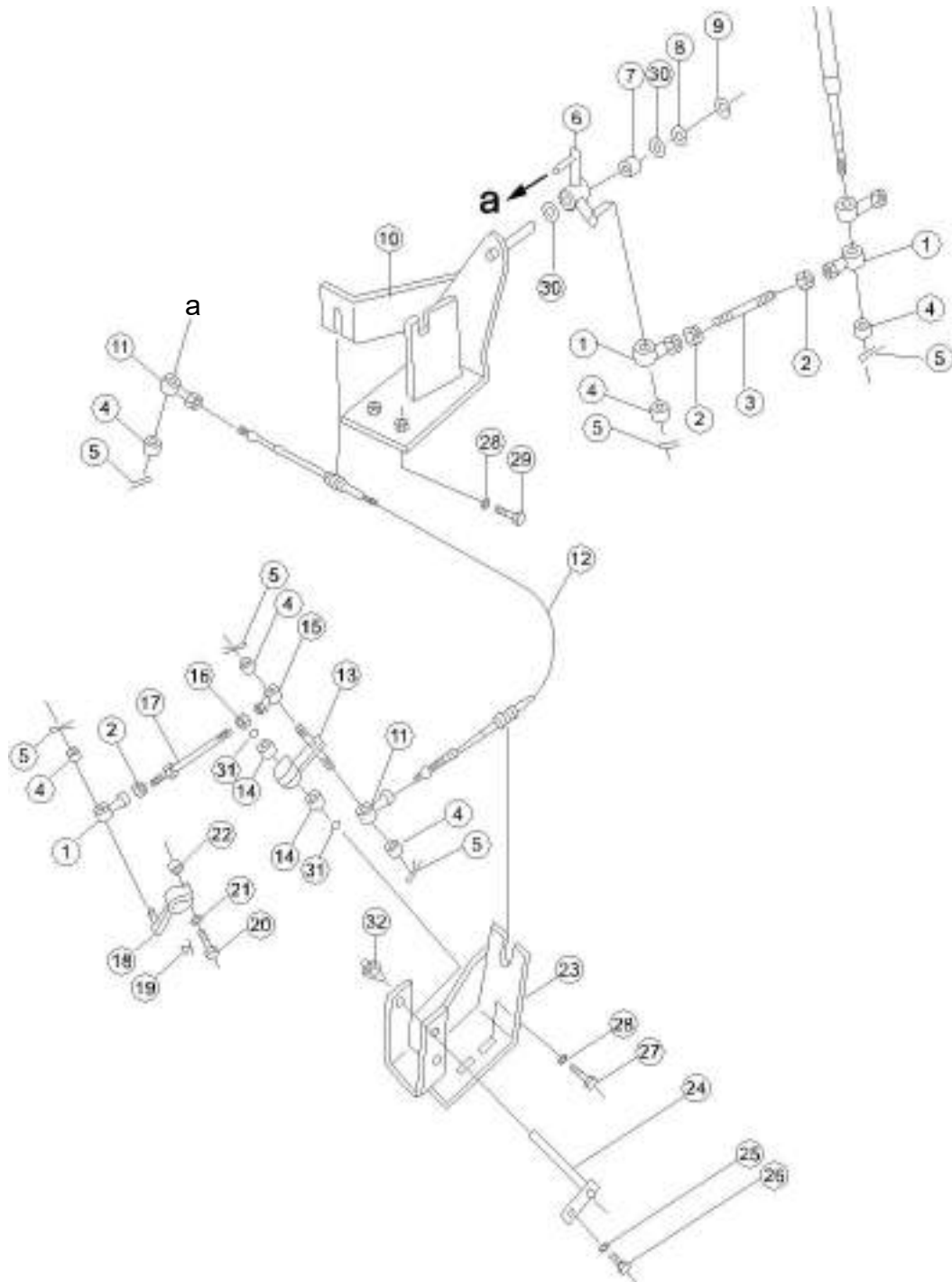

序号 NO.	部件号 PART NO.	零件名称 PART NAME		数量 Q'TY	适用机型 MODEL
1	04250-41056	关节轴承	Joint bearing	3	
2	01582-11008	螺母 M10*1.25	Nut M10*1.25	3	
3	04245-41007	杆	Lever	1	
4	01593-11008	螺母 M10*1.25	Nut M10*1.25	6	
5	04050-12018	开口销	Cotter pin	6	
6	175-43-41234	摇臂	Rock arm	1	
7	GB290-HK2016	冲压外圈滚针轴承	Needle roller bearing	1	
8	01640-21826	垫圈 18	Washer 18	1	
9	04064-01812	挡圈	Retainer ring	1	
10	175-43-42680	支架	Bracket	1	
11	195-43-25170	关节轴承	Joint bearing	2	
12	195-43-25180	软轴	Flexible shaft	1	
13	175-43-42570	摇臂	Rock arm	1	
14	GB290-HK1612	冲压外圈滚针轴承	Needle roller bearing	2	
15	04250-61056	关节轴承	Joint bearing	1	
16	01508-41006	螺母 M10*1.25 左	Nut (L.H.) M10*1.25	1	
17	04248-31026	杆	Lever	1	
18	175-43-41311	摇臂	Rock arm	1	
19	04010-10516	半圆键	Woodruff Key	1	
20	01016-50850	螺栓 M8*50	Bolt M8*50	1	
21	01602-20825	垫圈 8	Washer 8	1	
22	01580-10806	螺母 M8	Nut M8	1	
23	175-43-42560	支架	Bracket	1	
24	175-43-42581	销轴	Pin shaft	1	
25	01602-20619	垫圈 6	Washer 6	1	
26	01010-50616	螺栓 M6*16	Bolt M6*16	1	
27	01010-51225	螺栓 M12*25	Bolt M12*25	2	
28	01643-31232	垫圈 12	Washer 12	4	
29	01010-51230	螺栓 M12*30	Bolt M12*30	2	
30	06122-02004	防尘密封圈	Ring, Dust	2	
31	06122-01603	防尘密封圈	Ring, Dust	2	
32	07020-00613	油杯 M6	Oil cup M6	2	

# 变速油泵 TRANSMISSION PUMP

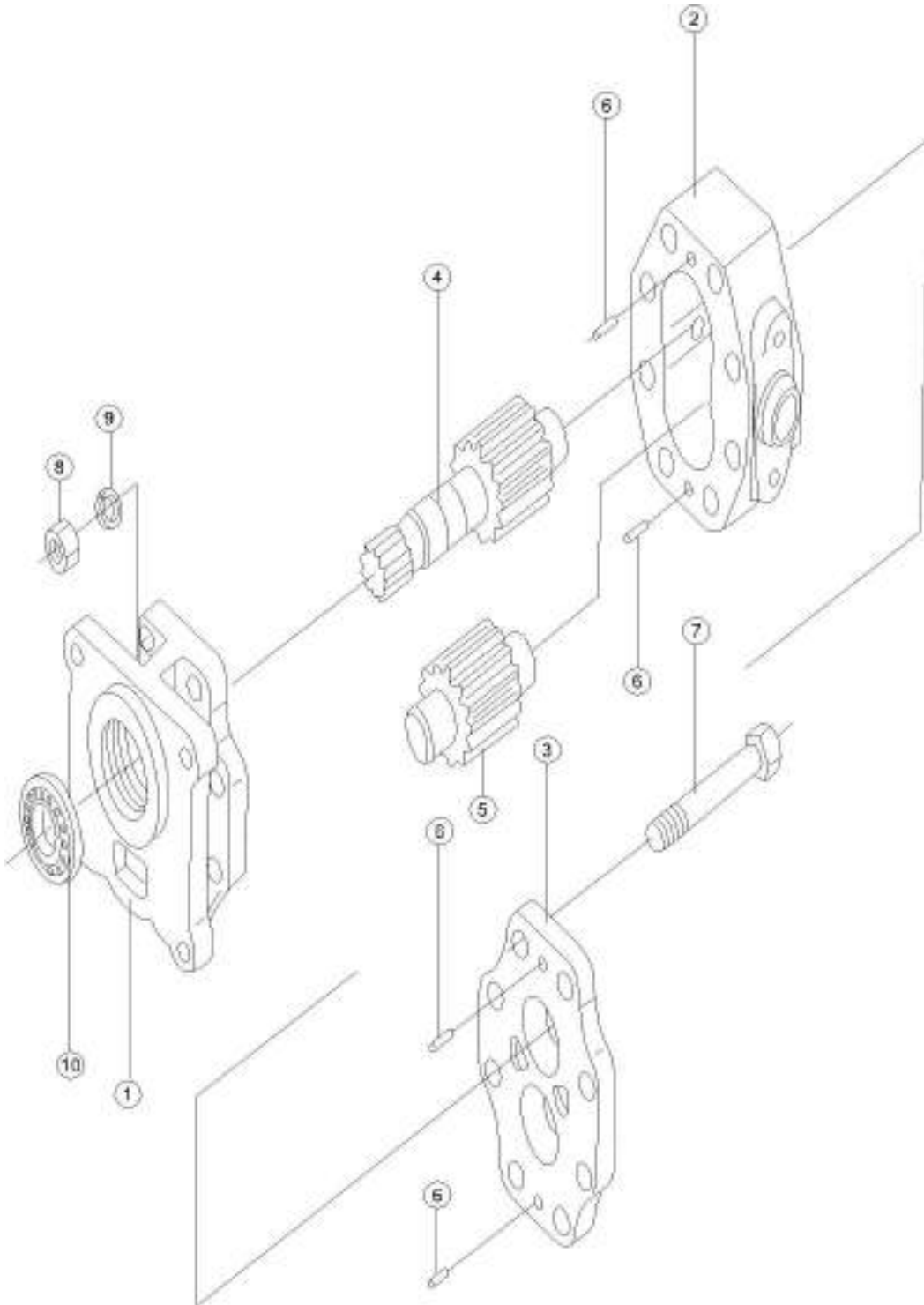

零件图册 | 变矩器和变速箱

序号 NO.	部件号 PART NO.	零件名称 PART NAME		数量 Q'TY	适用机型 MODEL
1	07430-71113	泵座组件	Bracket, Pump	1	
2	07433-71021	泵体	Body, Pump	1	
3	07430-71132	泵盖组件	Cover, Pump	1	
4	07433-71042	主动齿轮	Driving gear	1	
5	07433-71052	被动齿轮	Driven gear	1	
6	04020-00820	圆柱销	Cylindrical pin	4	
7	01050-51295	螺栓 M12*1.5*95	Bolt M12*1.5*95	8	
8	01582-11210	螺母 M12*1.5	Nut M12*1.5	8	
9	01602-21236	垫圈 12	Washer 12	8	
10	07430-71160	油封	Oil seal	1	

### 精滤器总成 FINE FILTER ASS'Y

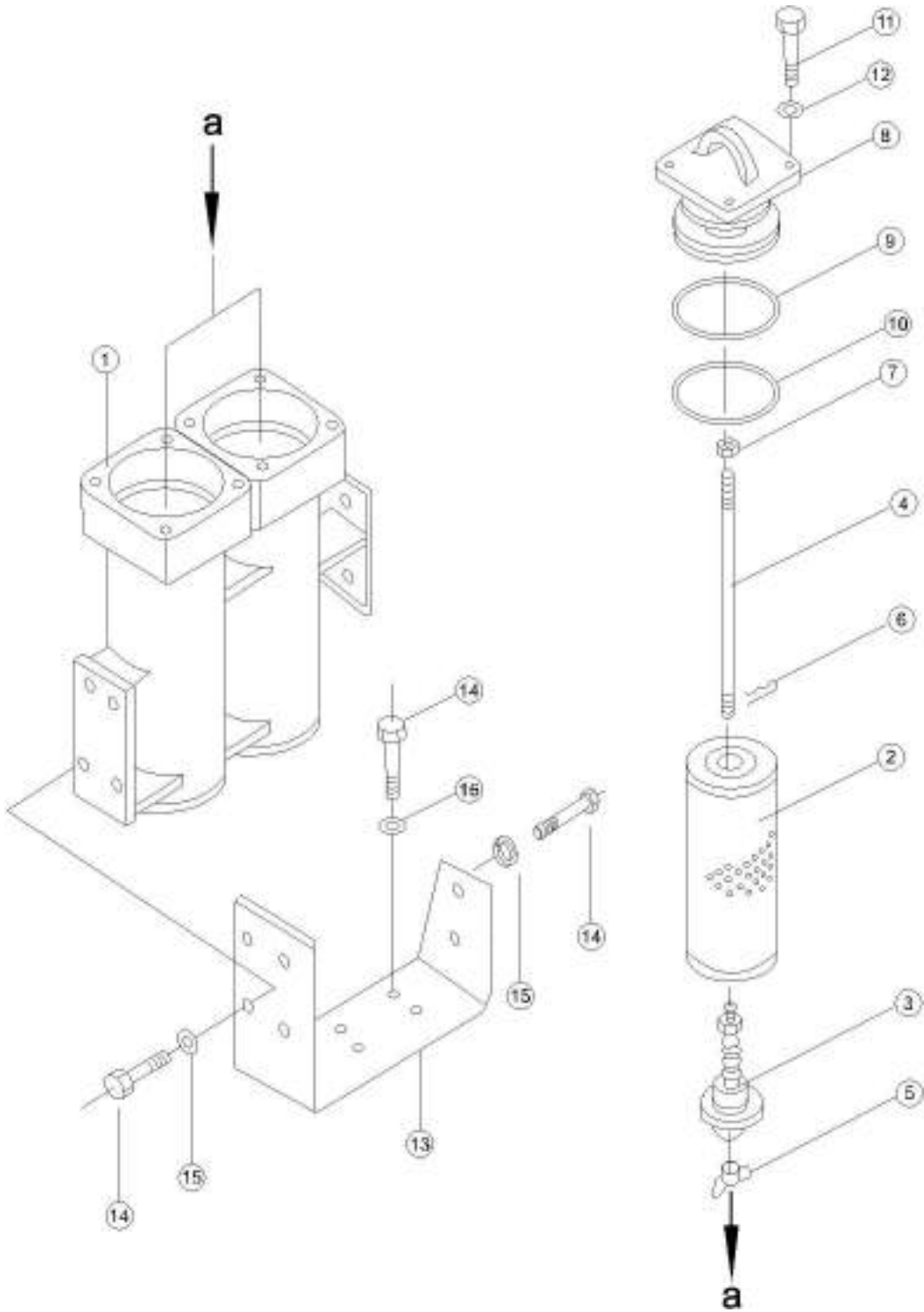

序号 NO.	部件号 PART NO.	零件名称 PART NAME		数量 Q'TY	适用机型 MODEL
1	171-74-01100	箱体	Box body	1	
2	175-49-11580	滤网	Filter screen	2	
3	175-49-25530	阀	Valve	2	
4	175-49-25540	杆	Lever	2	
5	01540-21050	蝶形螺母	Butterfly-shaped nut	2	
6	04050-02018	开口销	Cotter pin	2	
7	01582-01008	螺母 M10*1.25	Nut M10*1.25	2	
8	195-49-13740	盖	Cover	2	
9	07000-12115	O 形圈	O-ring	2	
10	07000-12110	O 形圈	O-ring	2	
11	01010-51440	螺栓 M14*40	Bolt M14*40	8	
12	01643-31445	垫圈 14	Washer 14	8	
13	171-74-02000	支架	Bracket	1	
14	01010-51235	螺栓 M12*35	Bolt M12*35	10	
15	01602-21236	垫圈 12	Washer 12	6	
16	01643-31232	垫圈 12	Washer 12	4	

# 变矩器管路系统 TORQUE CONVERTER PIPING SYSTEM

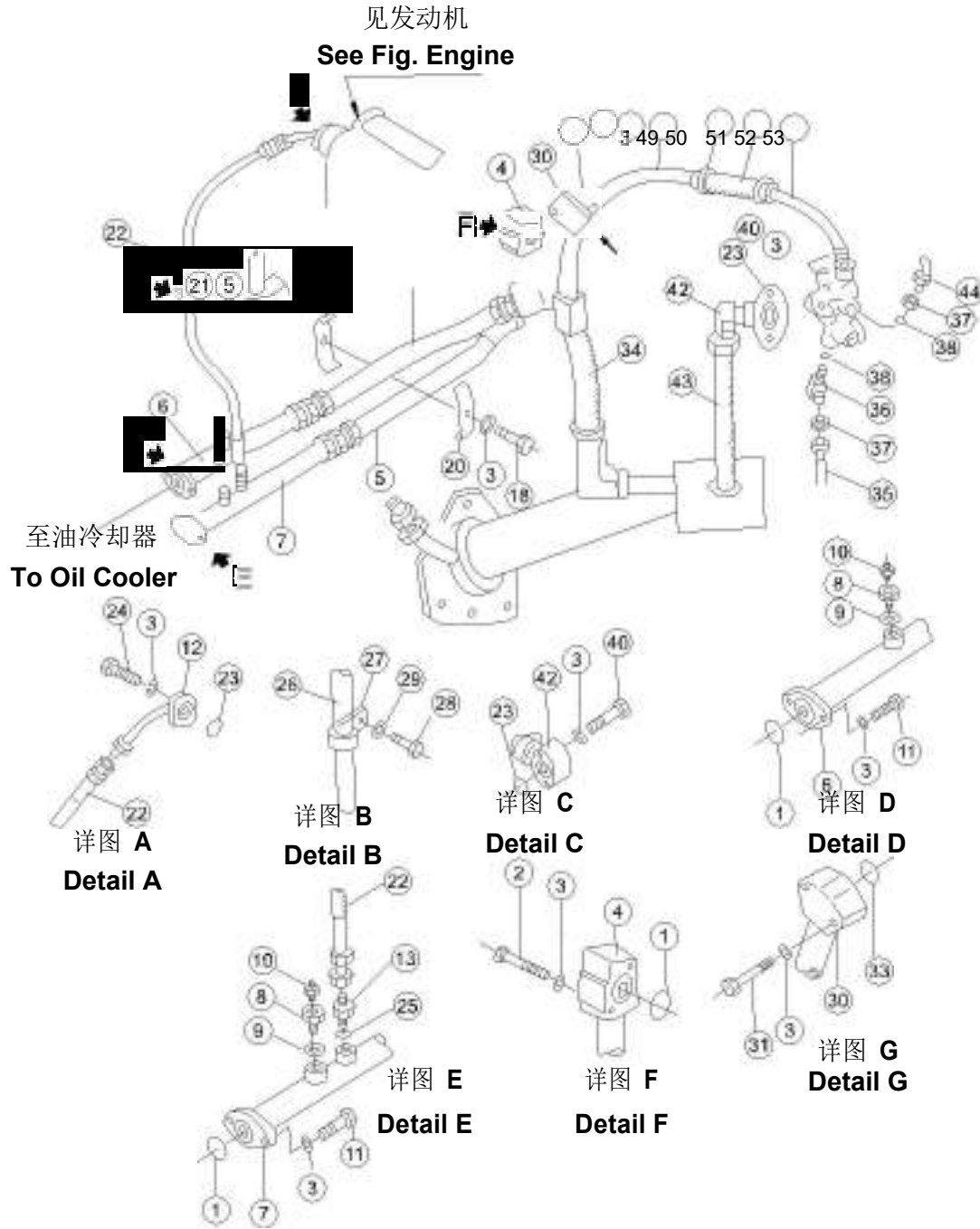

序号 NO.	部件号 PART NO.	零件名称 PART NAME		数量 Q'TY	适用机型 MODEL
1	07000-13042	O 形圈	O-ring	3	
2	01010-51070	螺栓 M10*70	Bolt M10*70	2	
3	01602-21030	垫圈 10	Washer 10	15	
4	175-49-C1160	管子	Tube	1	
5	07100-21406	软管	Hose	2	
6	175-49-C1180A	管	Tube	1	
7	175-49-C1190A	管	Tube	1	
8	154-19-17122	塞	Plug	2	
9	07005-01612	密封垫圈	Sealing gasket	2	
10	07042-20108	螺塞	Screw plug	2	
11	01010-51040	螺栓 M10*40	Bolt M10*40	4	
12	175-49-C1210	管子	Tube	1	
13	07230-20422	管接头	Nipple	1	
18	01010-51050	螺栓 M10*50	Bolt M10*50	1	
20	175-61-14760	夹子	Clamp	1	
21	175-61-14770	夹子	Clamp	1	
22	07102-20406	软管	Hose	1	
23	07000-13028	O 形圈	O-ring	1	
24	01010-51030	螺栓 M10*30	Bolt M10*30	2	
25	07002-12034	O 形圈	O-ring	1	
26	150-04-12320	管子	Tube	1	
27	154-04-12420	夹子	Clamp	1	
28	01010-51220	螺栓 M12*20	Bolt M12*20	1	
29	01602-21236	垫圈 12	Washer 12	1	
30	175-49-C1221	管子	Tube	1	
31	01010-51075	螺栓 M10*75	Bolt M10*75	2	
33	07000-13040	O 形圈	O-ring	1	
34	07102-20603	软管	Hose	1	
35	07102-21011	软管	Hose	1	
36	07232-11034	接头	Nipple	1	
37	07239-13320	螺母	Nut	2	
38	07002-13334	O 形圈	O-ring	2	
40	01010-51055	螺栓 M10*55	Bolt M10*55	2	
42	175-49-21483	管子	Tube	1	
43	07102-20403	软管	Hose	1	
44	175-49-23510	弯头	Elbow	1	
47	01010-50820	螺栓 M8*20	Bolt M8*20	2	

# 变矩器管路系统 TORQUE CONVERTER PIPING SYSTEM

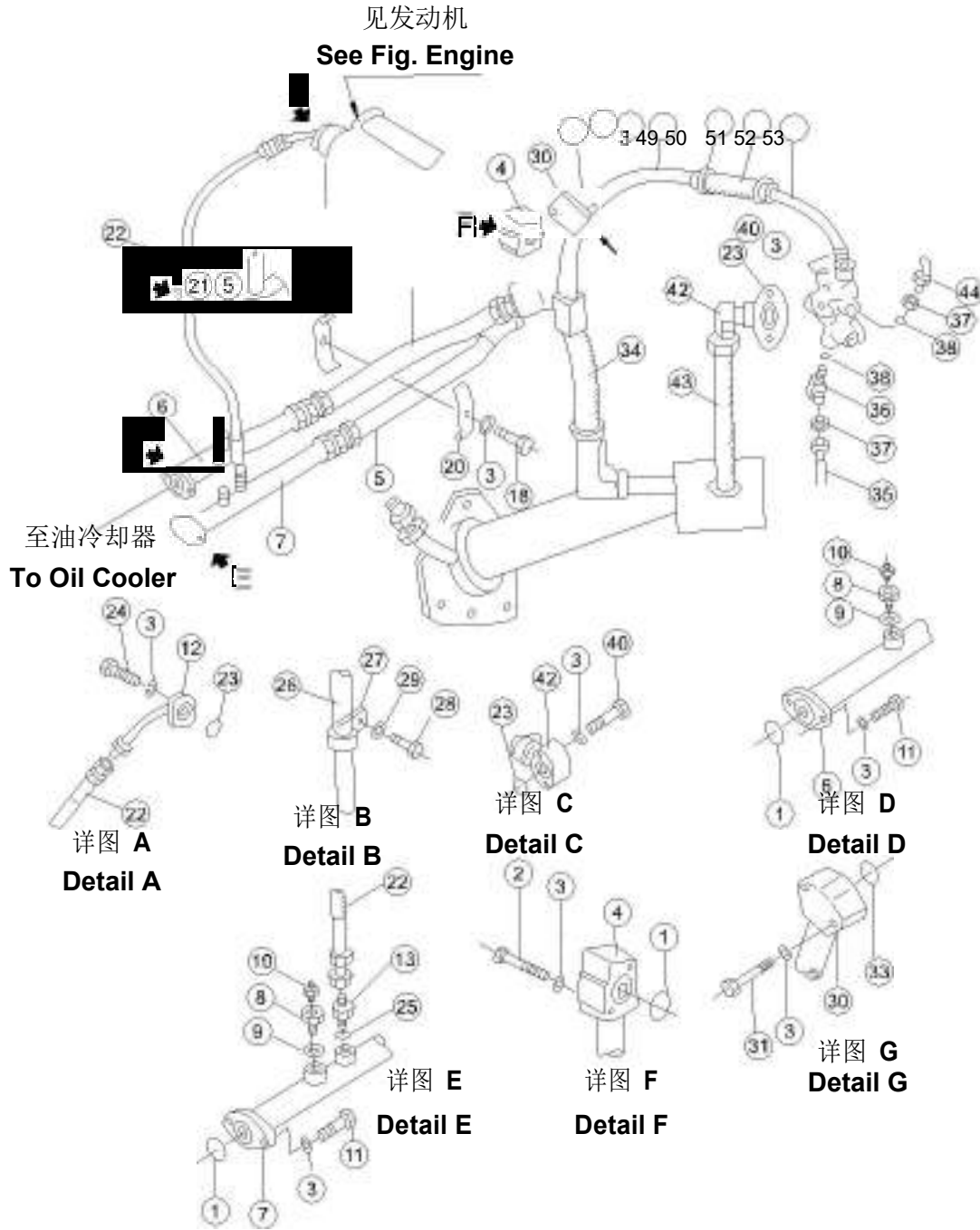

序号 NO.	部件号 PART NO.	零件名称 PART NAME	数量 Q'TY	适用机型 MODEL
49	07000-13035	O 形圈 O-ring	1	
50	175-49-25680	管子 Tube	1	
51	07281-00549	喉箍 Hose Clamp	2	
52	07260-03213	软管 Hose	1	
53	175-49-21434	管子 Tube	1	

# 变速箱管路系统 TORQUE TRANSMISSION PIPING SYSTEM

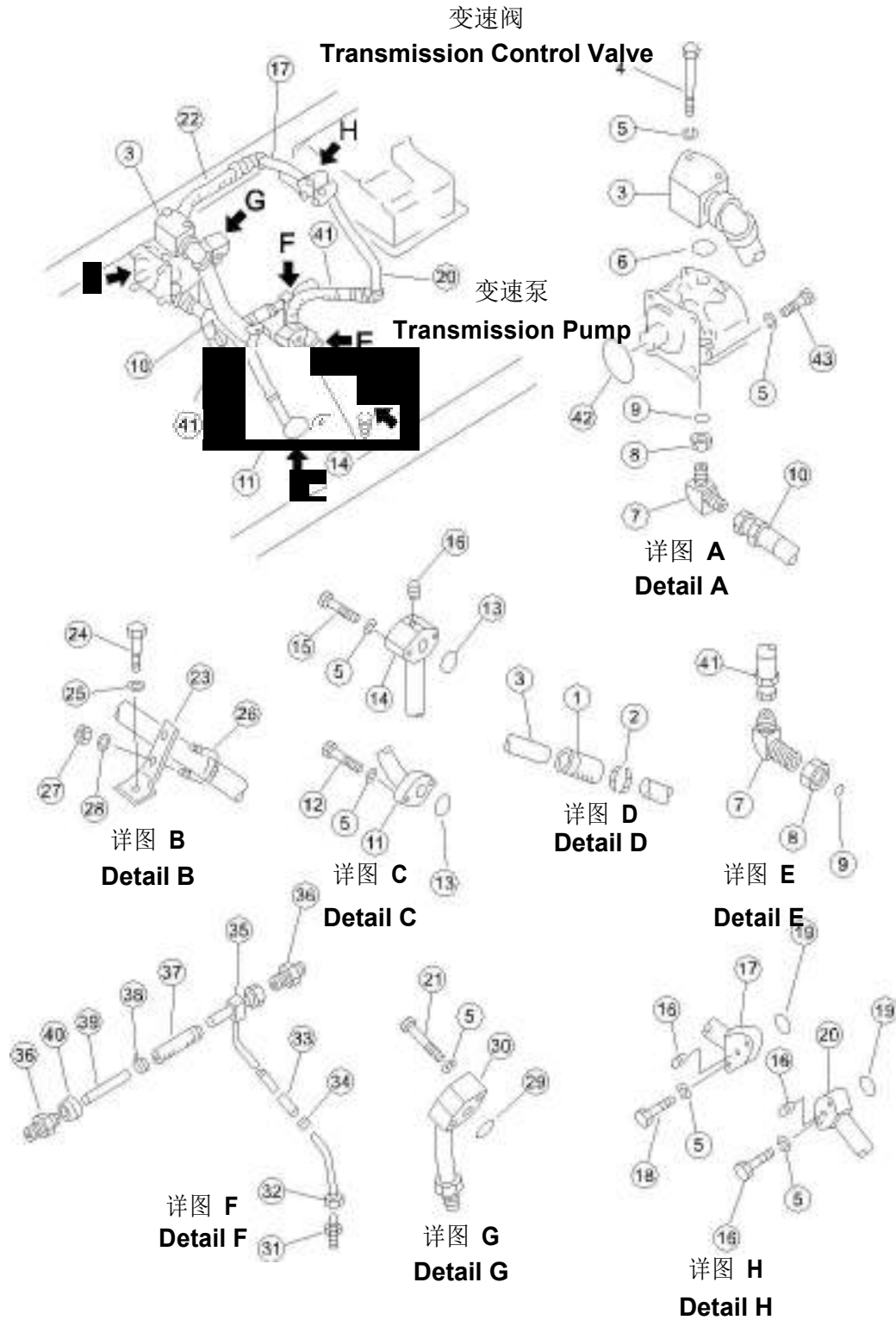

序号 NO.	部件号 PART NO.	零件名称 PART NAME	数量 Q'TY	适用机型 MODEL
1	07260-04117	软管 Hose	1	
2	07281-00609	喉箍 Hose Clamp	2	
3	175-49-22124	管 Tube	1	
4	01010-51080	螺栓 M10*80 Bolt M10*80	2	
5	01602-21030	垫圈 10 Washer 10	16	
6	07000-13032	O 形圈 O-ring	1	
7	07235-10628	弯头 Elbow	2	
8	07239-12410	螺母 Nut	2	
9	07002-12434	O 形圈 O-ring	2	
10	07102-20608	软管 Hose	1	
11	572-74-06000	管 Tube	1	
12	01010-51035	螺栓 M10*35 Bolt M10*35	2	
13	07000-13035	O 形圈 O-ring	2	
14	24G-74-02000	管 Tube	1	
15	01010-51055	螺栓 M10*55 Bolt M10*55	4	
16	07042-20108	螺塞 Screw plug	3	
17	175-49-23862	管子 Tube	1	
18	01010-51065	螺栓 M10*65 Bolt M10*65	2	
19	07000-13028	O 形圈 O-ring	2	
20	175-49-21235	管子 Tube	1	
21	01010-51060	螺栓 M10*60 Bolt M10*60	2	
22	07102-20612	软管 Hose	1	
23	175-49-22134	托架 Bracket	1	
24	01010-51635	螺栓 M16*35 Bolt M16*35	1	
25	01643-31645	垫圈 16 Washer 16	1	
26	07283-24354	管夹 Clip	1	
27	01599-01011	螺母 M10*1.25 Nut M10*1.25	2	
28	01643-31032	垫圈 10 Washer 10	2	
29	07000-13025	O 形圈 O-ring	1	
30	175-49-21472	管 Tube	1	
31	07213-81013	接头 Nipple	1	
32	175-49-23580	管子 Tube	1	
33	07260-00922	软管 Hose	1	
34	07281-00197	喉箍 Hose Clamp	2	
35	175-49-23570	管 Tube	1	
36	07213-81521	接头 Nipple	2	
37	07260-01410	软管 Hose	1	

# 变速箱管路系统 TORQUE TRANSMISSION PIPING SYSTEM

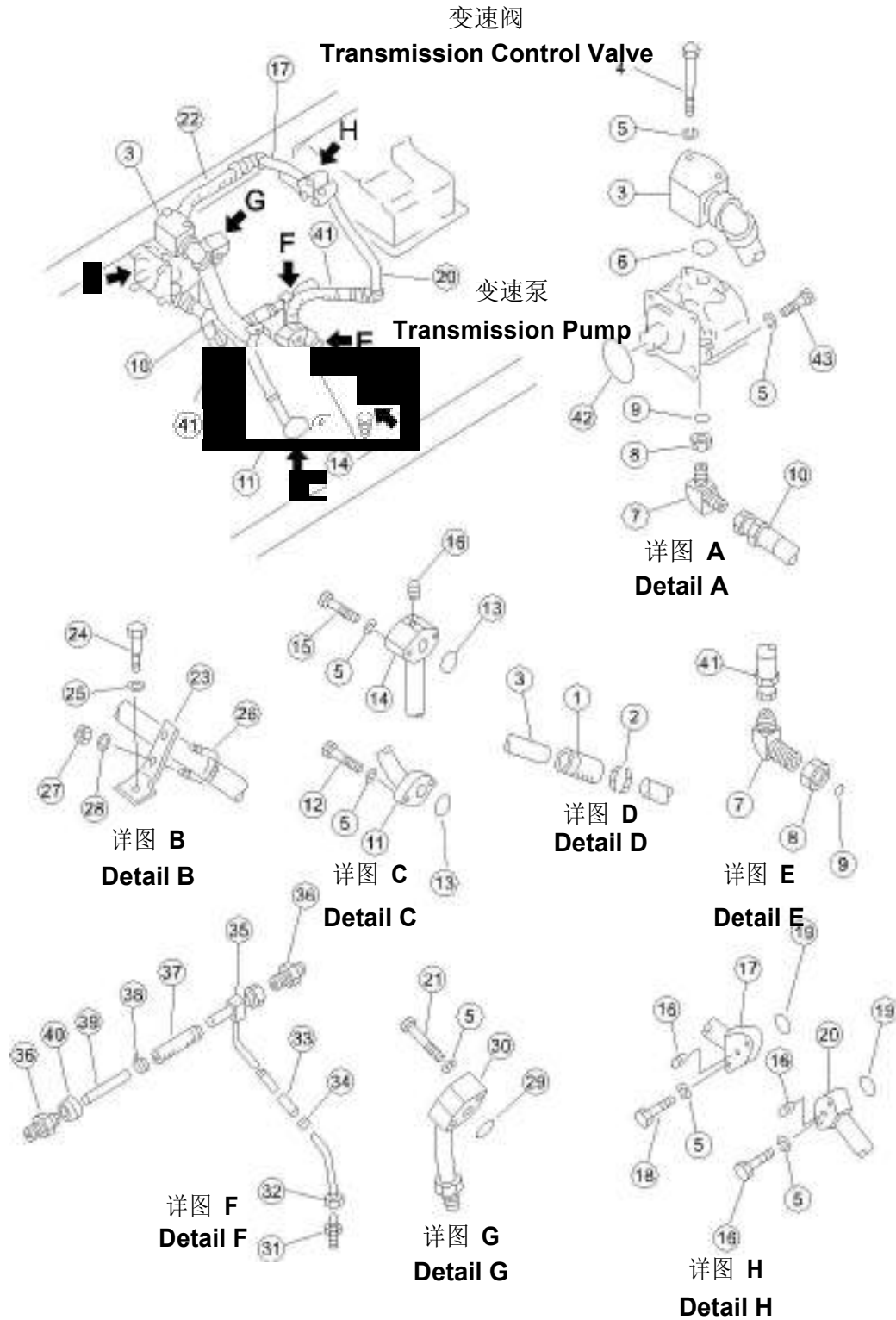

序号 NO.	部件号 PART NO.	零件名称 PART NAME		数量 Q'TY	适用机型 MODEL
38	07281-00259	喉箍	Hose Clamp	2	
39	175-49-11911	管子	Tube	1	
40	07201-51527	螺母	Nut	1	
41	07102-20603	软管	Hose	2	
42	07000-13075	O 形圈	O-ring	1	
43	01010-51030	螺栓 M10*30	Bolt M10*30	4	

变矩器管路系统 (配国 II 发动机)  
**TORQUE CONVERTER PIPING SYSTEM  
 (GOING WITH THE NATIONAL II-ENGINE)**

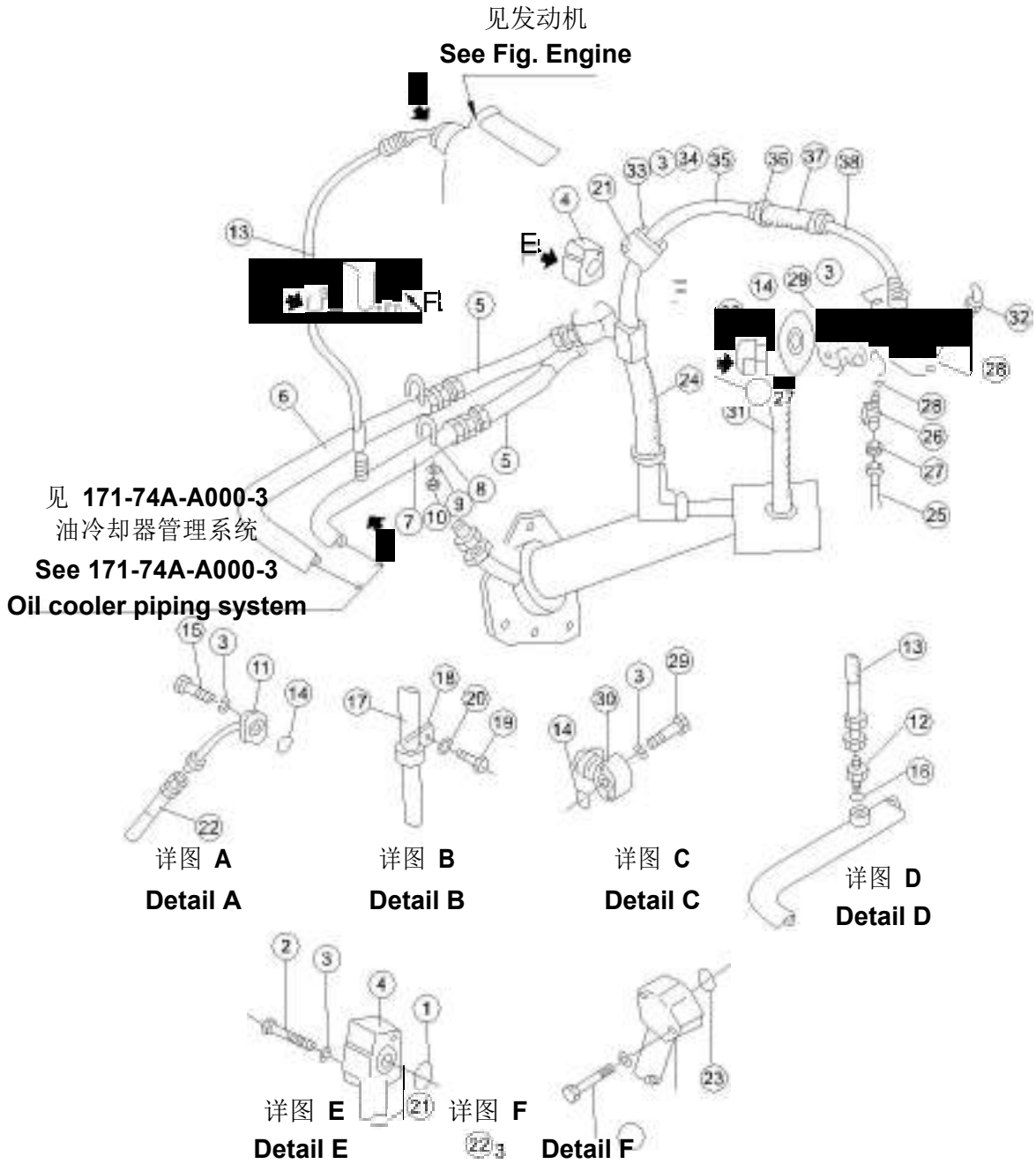

序号 NO.	部件号 PART NO.	零件名称 PART NAME		数量 Q'TY	适用机型 MODEL
1	07000-13042	O 形圈	O-ring	1	
2	01010-51070	螺栓 M10*70	Bolt M10*70	2	
3	01602-21030	垫圈 10	Washer 10	10	
4	175-49-C1160	管子	Tube	1	
5	07100-21403	软管	Hose	2	
6	171-74A-01000	硬管	Tube	1	
7	171-74A-02000	硬管	Tube	1	
8	07283-24346	管夹	Clip	2	
9	01599-01011	螺母 M10*1.25	Nut M10*1.25	4	
10	01643-31032	垫圈 10	Washer 10	4	
11	175-49-C1210	管子	Tube	1	
12	07230-20422	管接头	Nipple	1	
13	07102-20406	软管	Hose	1	
14	07000-13028	O 形圈	O-ring	2	
15	01010-51030	螺栓 M10*30	Bolt M10*30	2	
16	07002-12034	O 形圈	O-ring	1	
17	150-04-12320	管子	Tube	1	
18	154-04-12420	夹子	Clamp	1	
19	01010-51220	螺栓 M12*20	Bolt M12*20	1	
20	01602-21236	垫圈 12	Washer 12	1	
21	175-49-C1221	管子	Tube	1	
22	01010-51075	螺栓 M10*75	Bolt M10*75	2	
23	07000-13040	O 形圈	O-ring	1	
24	07102-20603	软管	Hose	1	
25	07102-21011	软管	Hose	1	
26	07232-11034	接头	Nipple	1	
27	07239-13320	螺母	Nut	2	
28	07002-13334	O 形圈	O-ring	2	
29	01010-51055	螺栓 M10*55	Bolt M10*55	2	
30	175-49-21483	管子	Tube	1	
31	07102-20403	软管	Hose	1	
32	175-49-23510	弯头	Elbow	1	
33	01010-50820	螺栓 M8*20	Bolt M8*20	2	
34	07000-13035	O 形圈	O-ring	1	
35	175-49-25680	管子	Tube	1	
36	07281-00549	喉箍	Hose Clamp	2	
37	07260-03213	软管	Hose	1	
38	175-49-21434	管子	Tube	1	

变速箱管路系统 (配国 II 发动机)  
**TORQUE CONVERTER PIPING SYSTEM  
 (GOING WITH THE NATIONAL II-ENGINE)**

变速阀

Transmission Control Valve

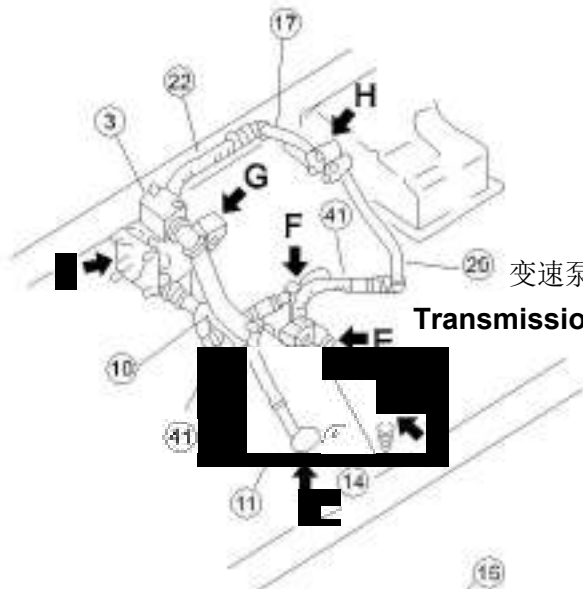

变速泵

Transmission Pump

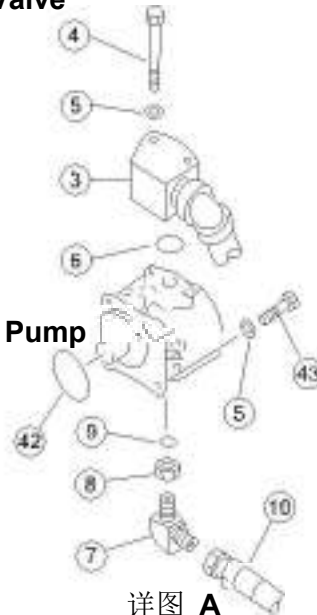

详图 A  
Detail A

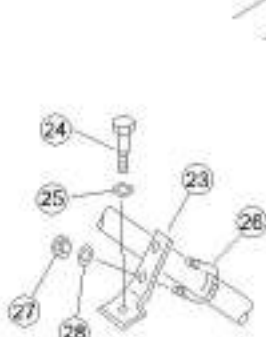

详图 B  
Detail B

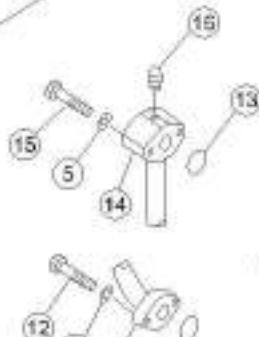

详图 C  
Detail C

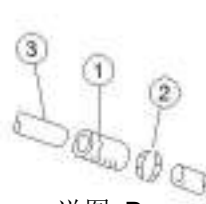

详图 D  
Detail D

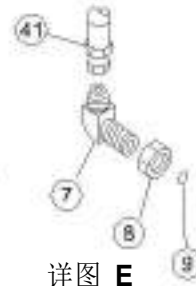

详图 E  
Detail E

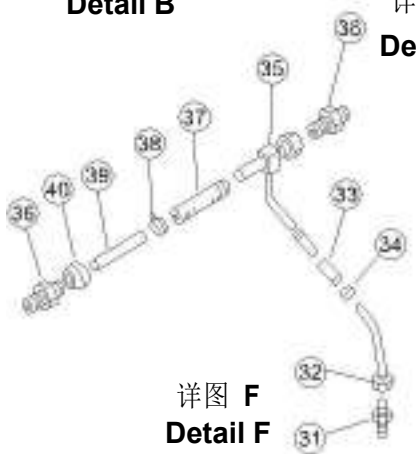

详图 F  
Detail F

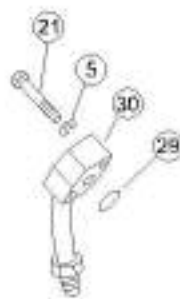

详图 G  
Detail G

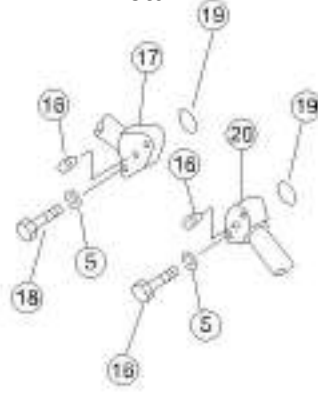

详图 H  
Detail H

序号 NO.	部件号 PART NO.	零件名称 PART NAME	数量 Q'TY	适用机型 MODEL
1	07260-04117	软管 Hose	1	
2	07281-00609	喉箍 Hose Clamp	2	
3	175-49-22124	管 Tube	1	
4	01010-51080	螺栓 M10*80 Bolt M10*80	2	
5	01602-21030	垫圈 10 Washer 10	16	
6	07000-13032	O 形圈 O-ring	1	
7	07235-10628	弯头 Elbow	2	
8	07239-12410	螺母 Nut	2	
9	07002-12434	O 形圈 O-ring	2	
10	07102-20608	软管 Hose	1	
11	572-74-06000	管 Tube	1	
12	01010-51035	螺栓 M10*35 Bolt M10*35	2	
13	07000-13035	O 形圈 O-ring	2	
14	24G-74-02000	管 Tube	1	
15	01010-51055	螺栓 M10*55 Bolt M10*55	4	
16	07042-20108	螺塞 Screw plug	3	
17	175-49-23862	管子 Tube	1	
18	01010-51065	螺栓 M10*65 Bolt M10*65	2	
19	07000-13028	O 形圈 O-ring	2	
20	175-49-21235	管子 Tube	1	
21	01010-51060	螺栓 M10*60 Bolt M10*60	2	
22	07102-20612	软管 Hose	1	
23	175-49-22134	托架 Bracket	1	
24	01010-51635	螺栓 M16*35 Bolt M16*35	1	
25	01643-31645	垫圈 16 Washer 16	1	
26	07283-24354	管夹 Clip	1	
27	01599-01011	螺母 M10*1.25 Nut M10*1.25	2	
28	01643-31032	垫圈 10 Washer 10	2	
29	07000-13025	O 形圈 O-ring	1	
30	175-49-21472	管 Tube	1	
31	07213-81013	接头 Nipple	1	
32	175-49-23580	管子 Tube	1	
33	07260-00922	软管 Hose	1	
34	07281-00197	喉箍 Hose Clamp	2	
35	175-49-23570	管 Tube	1	
36	07213-81521	接头 Nipple	2	
37	07260-01410	软管 Hose	1	

变速箱管路系统 (配国 II 发动机)  
**TORQUE CONVERTER PIPING SYSTEM  
 (GOING WITH THE NATIONAL II-ENGINE)**

变速阀

Transmission Control Valve

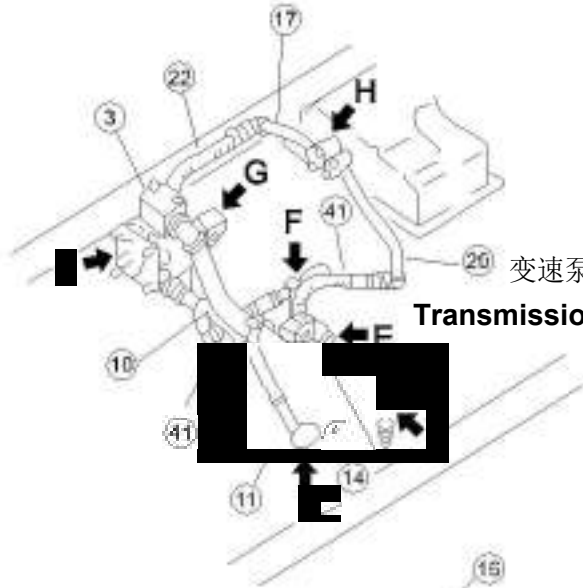

变速泵

Transmission Pump

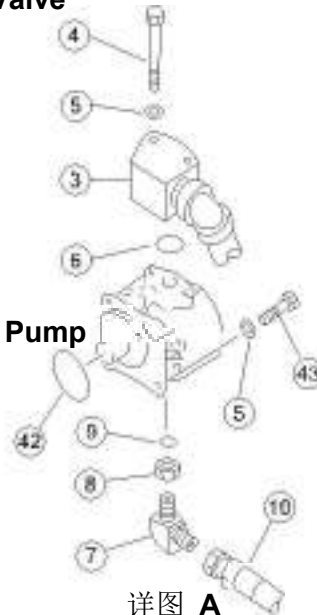

详图 A  
Detail A

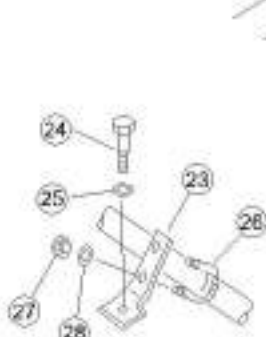

详图 B  
Detail B

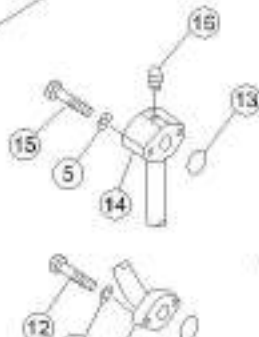

详图 C  
Detail C

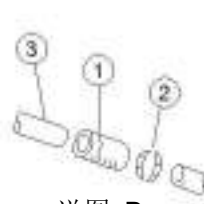

详图 D  
Detail D

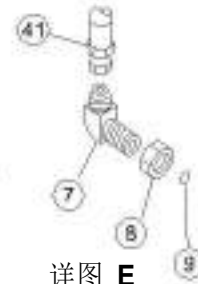

详图 E  
Detail E

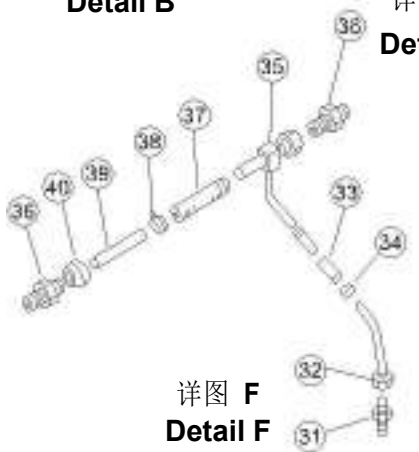

详图 F  
Detail F



详图 G  
Detail G

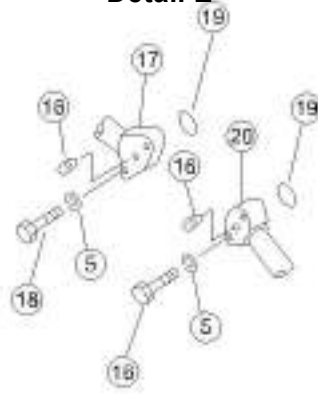

详图 H  
Detail H

序号 NO.	部件号 PART NO.	零件名称 PART NAME		数量 Q'TY	适用机型 MODEL
38	07281-00259	喉箍	Hose Clamp	2	
39	175-49-11911	管子	Tube	1	
40	07201-51527	螺母	Nut	1	
41	07102-20603	软管	Hose	2	
42	07000-13075	O 形圈	O-ring	1	
43	01010-51030	螺栓 M10*30	Bolt M10*30	4	

# 油冷却器管路系统 (配国 II 发动机) OIL COOLER PIPING SYSTEM (GOING WITH THE NATIONAL II-ENGINE)

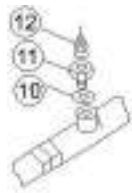
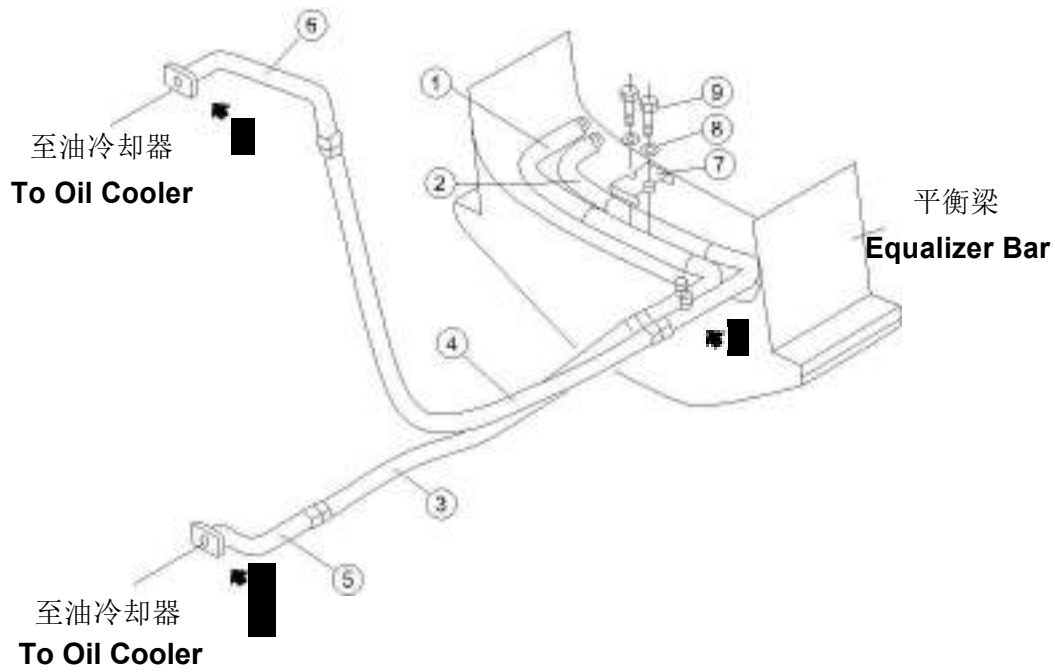

详图 A  
Detail A

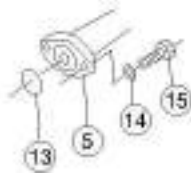

详图 B  
Detail B

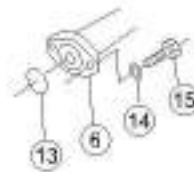

详图 C  
Detail C

序号 NO.	部件号 PART NO.	零件名称 PART NAME	数量 Q'TY	适用机型 MODEL
1	171-74A-01000	硬管 Tube	1	
2	171-74A-02000	硬管 Tube	1	
3	07100-21412	软管 Hose	1	
4	07100-21424	软管 Hose	1	
5	171-74A-04000	硬管 Tube	1	
6	171-74A-03000	硬管 Tube	1	
7	171-74A-00001	管夹 Clip	1	
8	01643-31032	垫圈 10 Washer 10	2	
9	01010-51040	螺栓 M10*40 Bolt M10*40	2	
10	07005-01612	密封垫圈 Sealing gasket	2	
11	154-19-17122	塞 Plug	2	
12	07042-20108	螺塞 Screw plug	2	
13	07000-13042	O 形圈 O-ring	2	
14	01602-21236	垫圈 12 Washer 12	8	
15	01010-51250	螺栓 M12*50 Bolt M12*50	8	



转向系统和终传动

## **STEERING SYSTEM AND FINAL DRIVE**

### 主机架与后桥箱 MAIN FRAME AND STEERING CASE

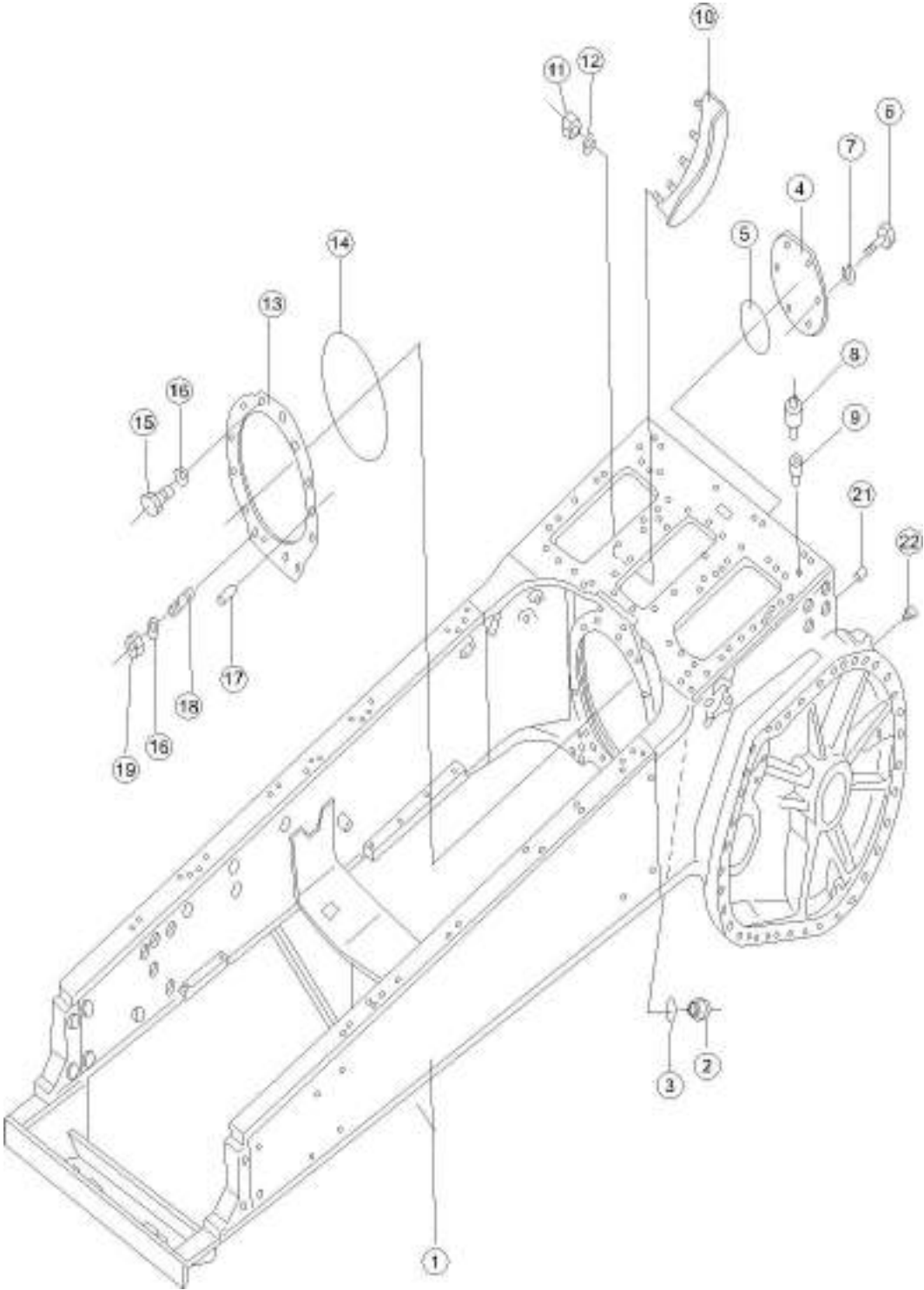

序号 NO.	部件号 PART NO.	零件名称 PART NAME	数量 Q'TY	适用机型 MODEL
1	171-30-01000	主机架与后桥箱 Main frame and steering case	1	
2	07044-13620	螺塞 Screw plug	1	
3	07002-13634	O 形圈 O-ring	1	
4	175-21-32170	盖 Cover	1	
5	07000-15195	O 形圈 O-ring	1	
6	01010-52040	螺栓 M20*40 Bolt M20*40	6	
7	01602-22060	弹簧垫圈 20 Spring washer 20	6	
8	07030-00252	通气塞 Breather plug	3	
9	170-21-11190	弯管接头 Elbow	3	
10	175-21-11181	罩 Cover	1	
11	01580-11210	螺母 Nut	3	
12	01602-21236	垫圈 12 Washer 12	3	
13	175-21-32135	垫片 Shim	1	
14	07000-15470	O 形圈 O-ring	1	
15	01010-52050	螺栓 M20*50 Bolt M20*50	6	
16	01643-32060	垫圈 20 Washer 20	11	
17	04020-01842	圆柱销 Cylindrical pin	1	
18	01120-52050	螺柱 Stud	5	
19	01582-02016	螺母 M20*1.5 Nut M20*1.5	5	
21	07049-02025	防尘塞 Plug, Dust	2	
22	07049-03949	防尘塞 Plug, Dust	22	

# 加油管与油尺 OIL FILTER AND LEVEL GAUGE

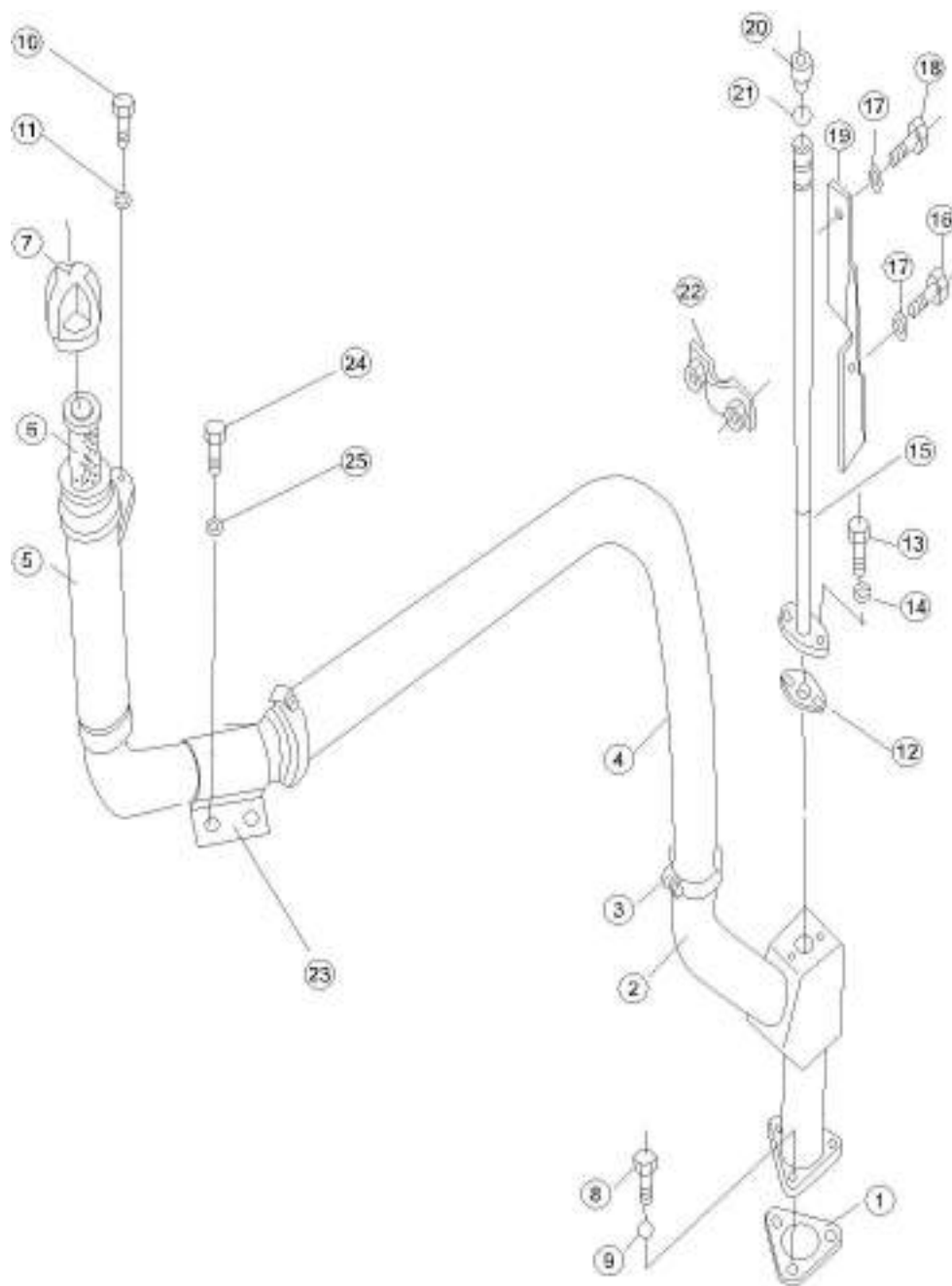

序号 NO.	部件号 PART NO.	零件名称 PART NAME	数量 Q'TY	适用机型 MODEL
1	154-21-11581	垫片 Washer	1	
2	171-30-02000	管 Tube	1	
3	07281-00549	喉箍 Hose Clamp	2	
4	171-30-00001	热成型软管 Hose	1	
5	171-30-03000	管 Tube	1	
6	07056-10045	过滤网 Filter screen	1	
7	07051-20000	加油口盖 Filler cap	1	
8	01010-51235	螺栓 M12*35 Bolt M12*35	3	
9	01602-21236	垫圈 12 Washer 12	3	
10	01010-51020	螺栓 M10*20 Bolt M10*20	2	
11	01643-31032	垫圈 10 Washer 10	2	
12	175-21-35210	垫片 Shim	1	
13	01010-50825	螺栓 M8*25 Bolt M8*25	2	
14	01602-20825	垫圈 8 Washer 8	2	
15	171-30-04000	管 Tube	1	
16	01010-51025	螺栓 M10*25 Bolt M10*25	2	
17	01602-21030	垫圈 10 Washer 10	4	
18	01010-51030	螺栓 M10*30 Bolt M10*30	2	
19	175-21-35410	板 Plate	1	
20	175-21-32153	油尺 Dipstick	1	
21	07000-12018	O 形圈 O-ring	1	
22	195-49-12990	卡箍 Clamp	1	
23	175-21-35242	卡箍 Clamp	1	
24	01010-51225	螺栓 M12*25 Bolt M12*25	2	
25	01643-31232	垫圈 12 Washer 12	2	

主机架与后桥箱（配国 II 发动机）  
**MAIN FRAME AND STEERING CASE**  
**(GOING WITH THE NATIONAL II-ENGINE)**

此组件用于康明斯国 II  
NTAA855-C360S20 型发动机  
This assembly is used for Cummins  
National II- NTAA855-C360S20 engine

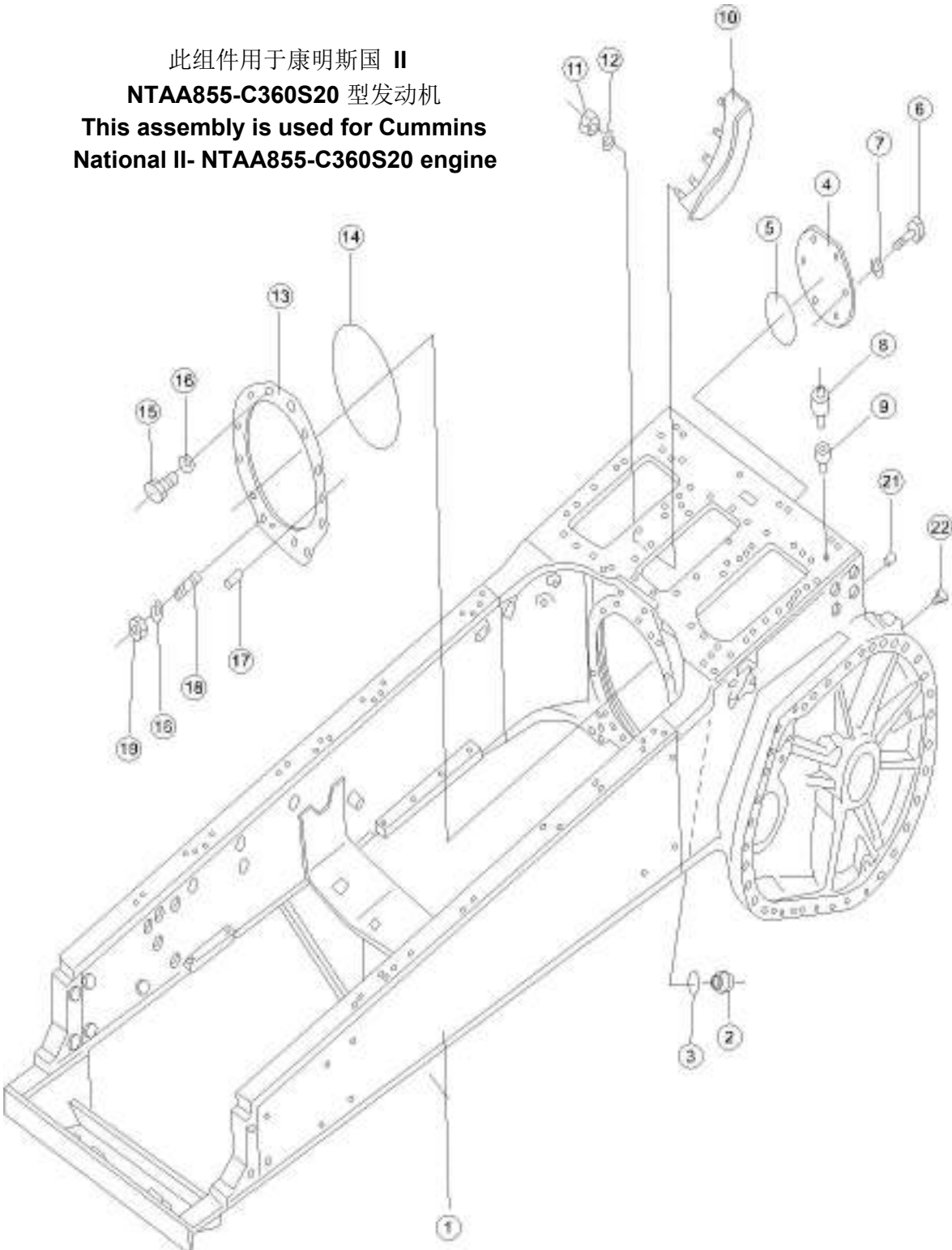

序号 NO.	部件号 PART NO.	零件名称 PART NAME		数量 Q'TY	适用机型 MODEL
1	171-30A-01000	主机架与后桥箱	Main frame and steering case	1	
2	07044-13620	螺塞	Screw plug	1	
3	07002-13634	O 形圈	O-ring	1	
4	175-21-32170	盖	Cover	1	
5	07000-15195	O 形圈	O-ring	1	
6	01010-52040	螺栓 M20*40	Bolt M20*40	6	
7	01602-22060	弹簧垫圈 20	Spring washer 20	6	
8	07030-00252	通气塞	Breather plug	3	
9	170-21-11190	弯管接头	Elbow	3	
10	175-21-11181	罩	Cover	1	
11	01580-11210	螺母	Nut	3	
12	01602-21236	垫圈 12	Washer 12	3	
13	175-21-32135	垫片	Shim	1	
14	07000-15470	O 形圈	O-ring	1	
15	01010-52050	螺栓 M20*50	Bolt M20*50	6	
16	01643-32060	垫圈 20	Washer 20	11	
17	04020-01842	圆柱销	Cylindrical pin	1	
18	01120-52050	螺柱	Stud	5	
19	01582-02016	螺母 M20*1.5	Nut M20*1.5	5	
21	07049-02025	防尘塞	Plug, Dust	2	
22	07049-03949	防尘塞	Plug, Dust	22	

加油管与油尺（配国 II 发动机）  
**OIL FILTER AND LEVEL GAUGE**  
**(GOING WITH THE NATIONAL II-ENGINE)**

此组件用于康明斯国 II  
NTAA855-C360S20 型发动机  
This assembly is used  
for Cummins National II-  
NTAA855-C360S20 engine

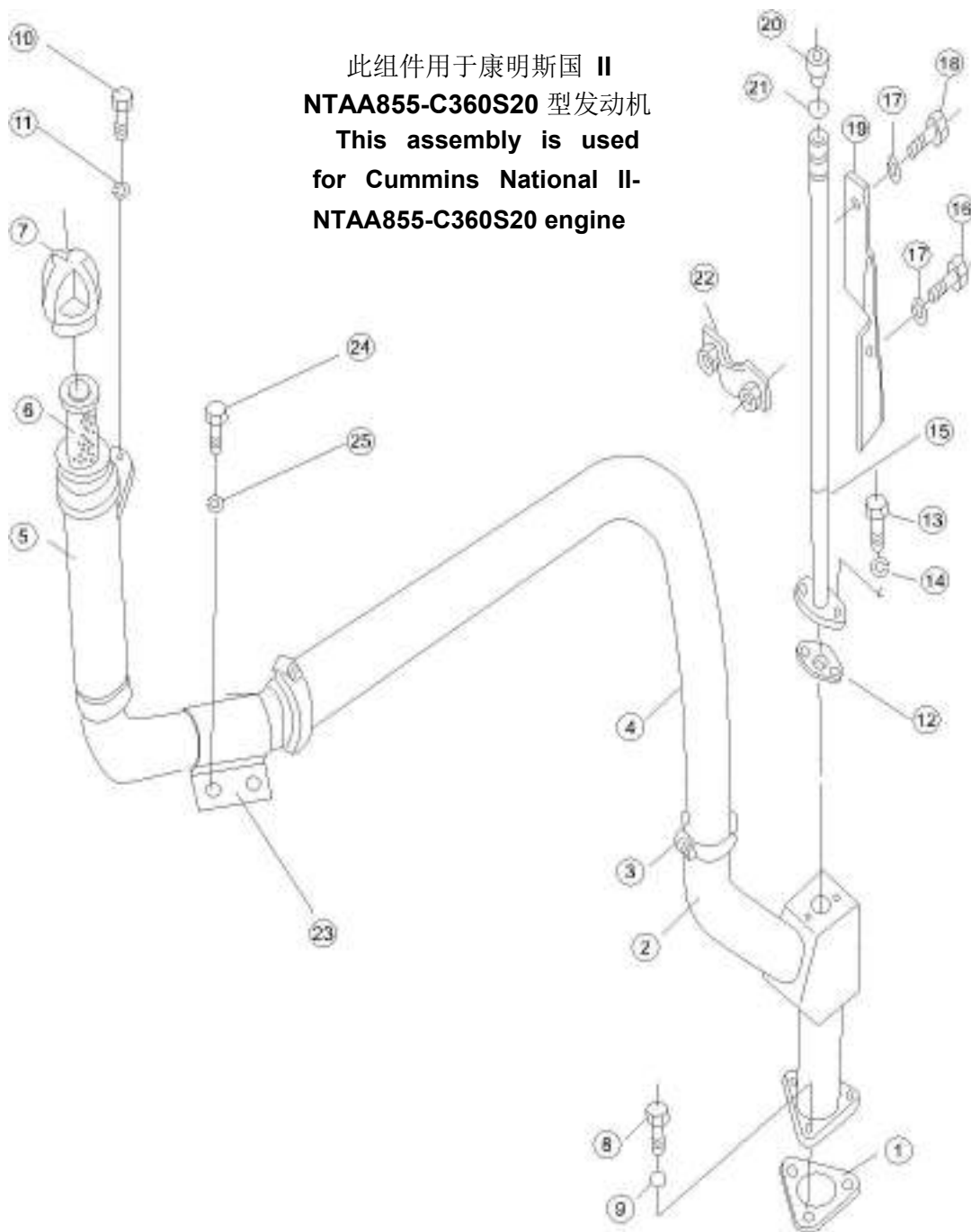

序号 NO.	部件号 PART NO.	零件名称 PART NAME	数量 Q'TY	适用机型 MODEL
1	154-21-11581	垫片 Washer	1	
2	171-30-02000	管 Tube	1	
3	07281-00549	喉箍 Hose Clamp	2	
4	171-30-00001	热成型软管 Hose	1	
5	171-30-03000	管 Tube	1	
6	07056-10045	过滤网 Filter screen	1	
7	07051-20000	加油口盖 Filler cap	1	
8	01010-51235	螺栓 M12*35 Bolt M12*35	3	
9	01602-21236	垫圈 12 Washer 12	3	
10	01010-51020	螺栓 M10*20 Bolt M10*20	2	
11	01643-31032	垫圈 10 Washer 10	2	
12	175-21-35210	垫片 Shim	1	
13	01010-50825	螺栓 M8*25 Bolt M8*25	2	
14	01602-20825	垫圈 8 Washer 8	2	
15	171-30-04000	管 Tube	1	
16	01010-51025	螺栓 M10*25 Bolt M10*25	2	
17	01602-21030	垫圈 10 Washer 10	4	
18	01010-51030	螺栓 M10*30 Bolt M10*30	2	
19	175-21-35410	板 Plate	1	
20	175-21-32153	油尺 Dipstick	1	
21	07000-12018	O 形圈 O-ring	1	
22	195-49-12990	卡箍 Clamp	1	
23	175-21-35242	卡箍 Clamp	1	
24	01010-51225	螺栓 M12*25 Bolt M12*25	2	
25	01643-31232	垫圈 12 Washer 12	2	

# 锥齿轮与轴 BEVEL GEAR AND SHAFT

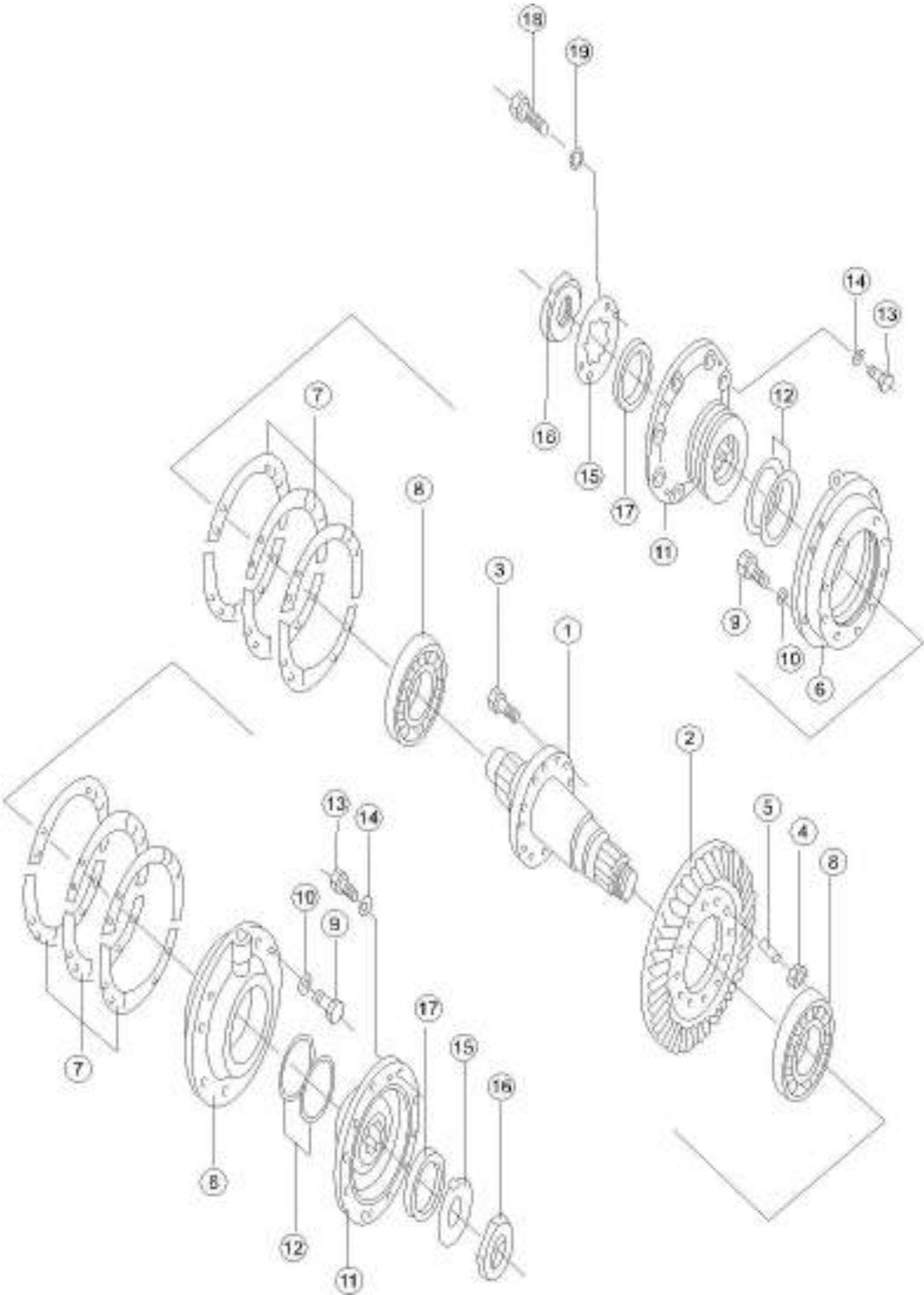

序号 NO.	部件号 PART NO.	零件名称 PART NAME		数量 Q'TY	适用机型 MODEL
1	175-21-32113	横轴	Cross shaft	1	
2	175-21-22140	螺旋伞齿轮	Spiral bevel gear	1	
3	170-21-12170	螺栓	Bolt	12	
4	01580-11613	螺母 M16	Nut M16	12	
5	170-21-12160	止动垫	Spacer	6	
6	175-21-32190	轴承座	Bearing support	2	
7.10	175-21-32210	垫片	Shim	20	
7.20	175-21-32220	垫片	Shim	20	
7.30	175-21-32230	垫片	Shim	16	
7	175-21-00032	垫片总成	Shim ass'y	2	
8	GB297-32219	圆锥滚子轴承	Tapered Roller Bearing	2	
9	01010-51440	螺栓 M14*40	Bolt M14*40	16	
10	01643-31445	垫圈 14	Washer 14	16	
11	198-21-11490	轮毂	Hub	2	
12	170-22-11130	密封环	Sealing ring	4	
13	01010-51645	螺栓 M16*45	Bolt M16*45	24	
14	01643-31645	垫圈 16	Washer 16	24	
15	198-21-11480	锁片	Locking plate	2	
16	170-21-12141	螺帽	Nut	2	
17	154-21-22211	衬垫	Gasket	2	
18	01010-51025	螺栓 M10*25	Bolt M10*25	4	
19	01643-31032	垫圈 10	Washer 10	4	

### 转向离合器总成 STEERING CLUTCH ASS'Y

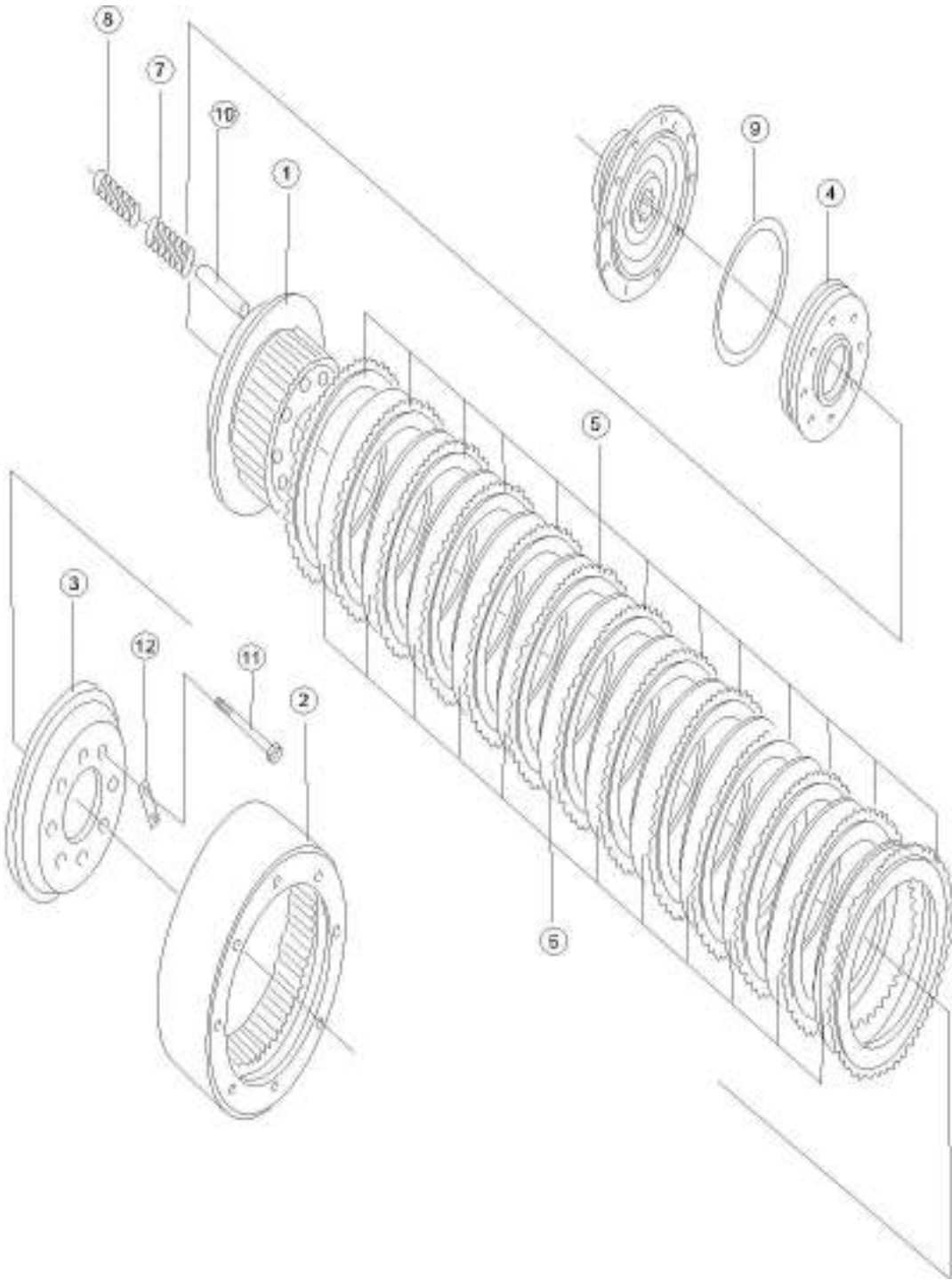

序号 NO.	部件号 PART NO.	零件名称 PART NAME		数量 Q'TY	适用机型 MODEL
1	175-22-21271	内鼓	Inner drum	1	
2	175-22-21281	外鼓	Outer drum	1	
3	175-22-21131	压盘	Platen	1	
4	175-22-21141	活塞	Piston	1	
5	154-22-11230	摩擦片	Friction disk	12	
6	175-22-21160	内齿片	Inner tooth	11	
7	175-22-21170	大弹簧	Big spring	8	
8	175-22-21180	小弹簧	Small spring	8	
9	175-22-21190	密封环	Sealing ring	1	
10	175-22-21231	套管	Sleeve	8	
11	175-22-21242	螺栓	Bolt	8	
12	175-22-21250	锁紧垫片	Lock washer	4	

### 制动带与联动装置 BRAKE BAND AND LINKAGE

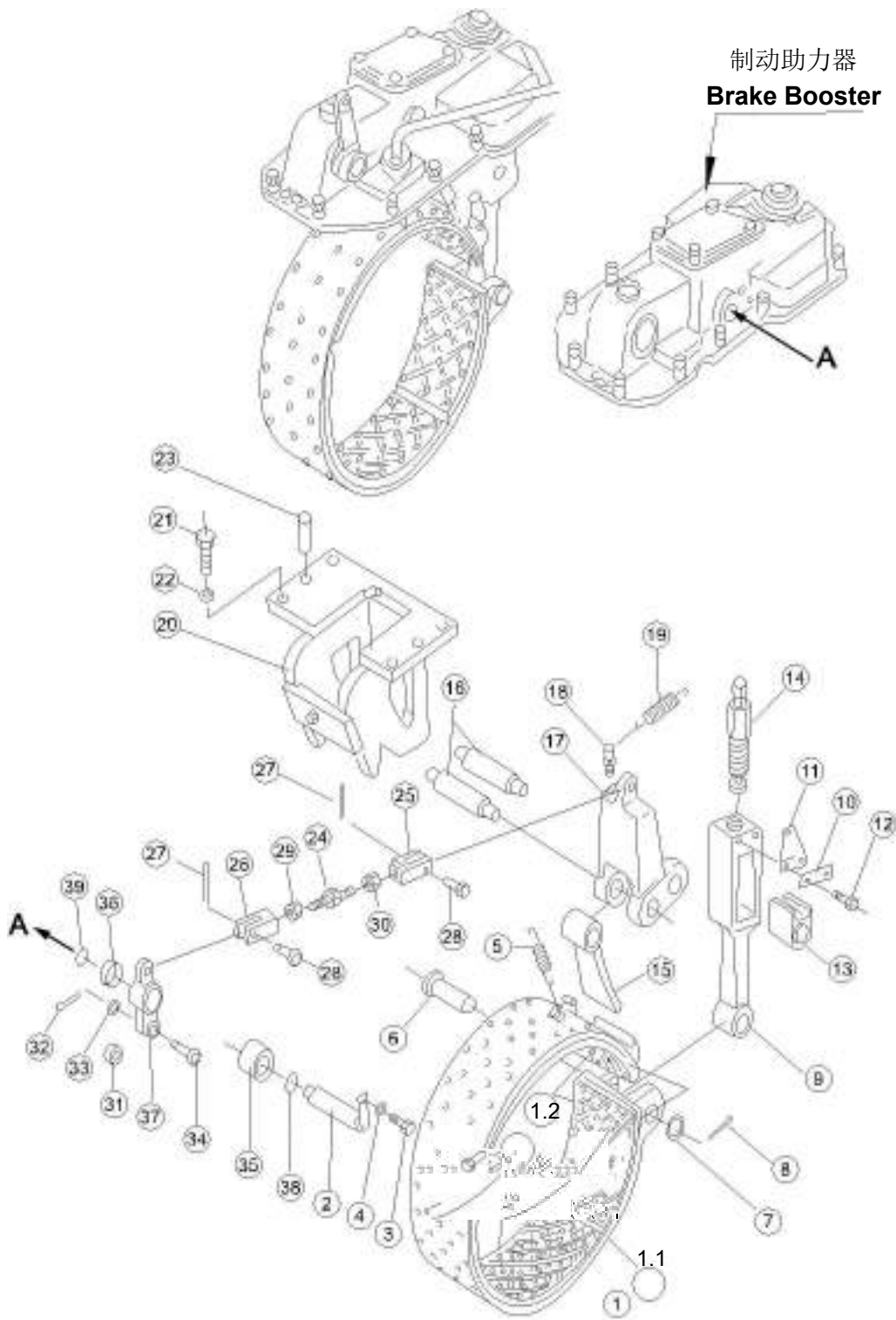

序号 NO.	部件号 PART NO.	零件名称 PART NAME	数量 Q'TY	适用机型 MODEL
1.40	04412-00514	铆钉	Rivet	198
1	175-33-28100	制动带总成	Brake band ass'y	1
1.10	175-33-28110	制动带	Brake band	1
1.20	175-33-28130	里衬	Liner	4
1.30	175-33-28140	里衬	Liner	6
1	175-33-28200	制动带总成	Brake band ass'y	1
1.10	175-33-28210	制动带	Brake band	1
2	154-33-21262	轴	Shaft	2
3	01010-51025	螺栓 M10*25	Bolt M10*25	2
4	01602-21030	垫圈 10	Washer 10	2
5	100-33-13120	弹簧	Spring	2
6	175-33-24210	销	Pin	2
7	175-33-24220	垫圈	Washer	2
8	04050-14050	开口销	Cotter pin	2
9	175-33-24231	拉杆	Lever	2
10	154-33-11620	锁板	Lock plate	2
11	154-33-11610	弹簧	Spring	2
12	01010-51016	螺栓 M10*16	Bolt M10*16	4
13	154-33-11540	锁块	Lock block	2
14	175-33-24272	螺杆	Screw	2
15	175-33-24240	端块	Terminal block	2
16	175-33-24260	锁轴	Lock shaft	4
17	175-33-24251	杆	Lever	2
18	154-33-11650	座	Seat	2
19	150-33-12171	弹簧	Spring	2
20	175-33-24281	左托架	L.H. Bracket	1
20	175-33-24291	右托架	R.H. Bracket	1
21	01010-52055	螺栓 M20*55	Bolt M20*55	8
22	01643-32060	垫圈 20	Washer 20	8
23	154-33-11720	定位销	Pin, Dowel	4
24	175-33-24311	螺杆	Screw	2
25	175-33-24320	叉头	Forkhead	2
26	175-33-24330	叉头	Forkhead	2
27	04050-04028	开口销	Cotter pin	4
28	175-33-24450	销子	Pin	4
29	01583-51811	螺母 M18*1.5	Nut M18*1.5	2
30	175-33-24342	螺母	Nut	2

# 制动带与联动装置 BRAKE BAND AND LINKAGE

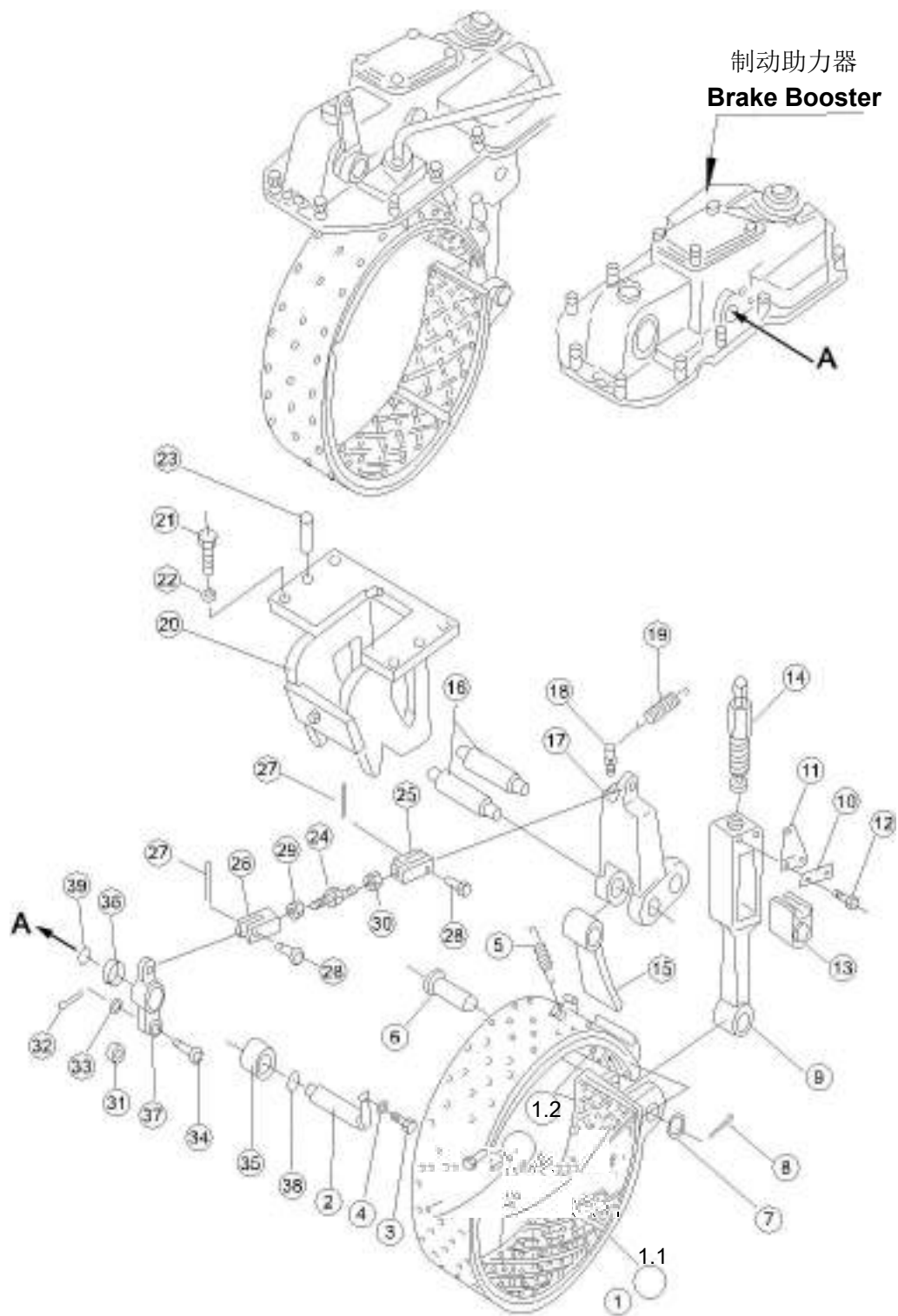

序号 NO.	部件号 PART NO.	零件名称 PART NAME		数量 Q'TY	适用机型 MODEL
31	170-33-13330	滚子	Roller	2	
32	04050-14026	开口销	Cotter pin	2	
33	01641-21626	垫圈 16	Washer 16	2	
34	04205-01645	销轴	Pin shaft	2	
35	198-43-13220	垫圈	Washer	2	
36	154-33-21280	衬套	Bushing	2	
37	175-33-24353	摇杆	Rocker	2	
38	07000-13030	O 形圈	O-ring	2	
39	07000-13025	O 形圈	O-ring	2	

# 制动助力器 BRAKE BOOSTER

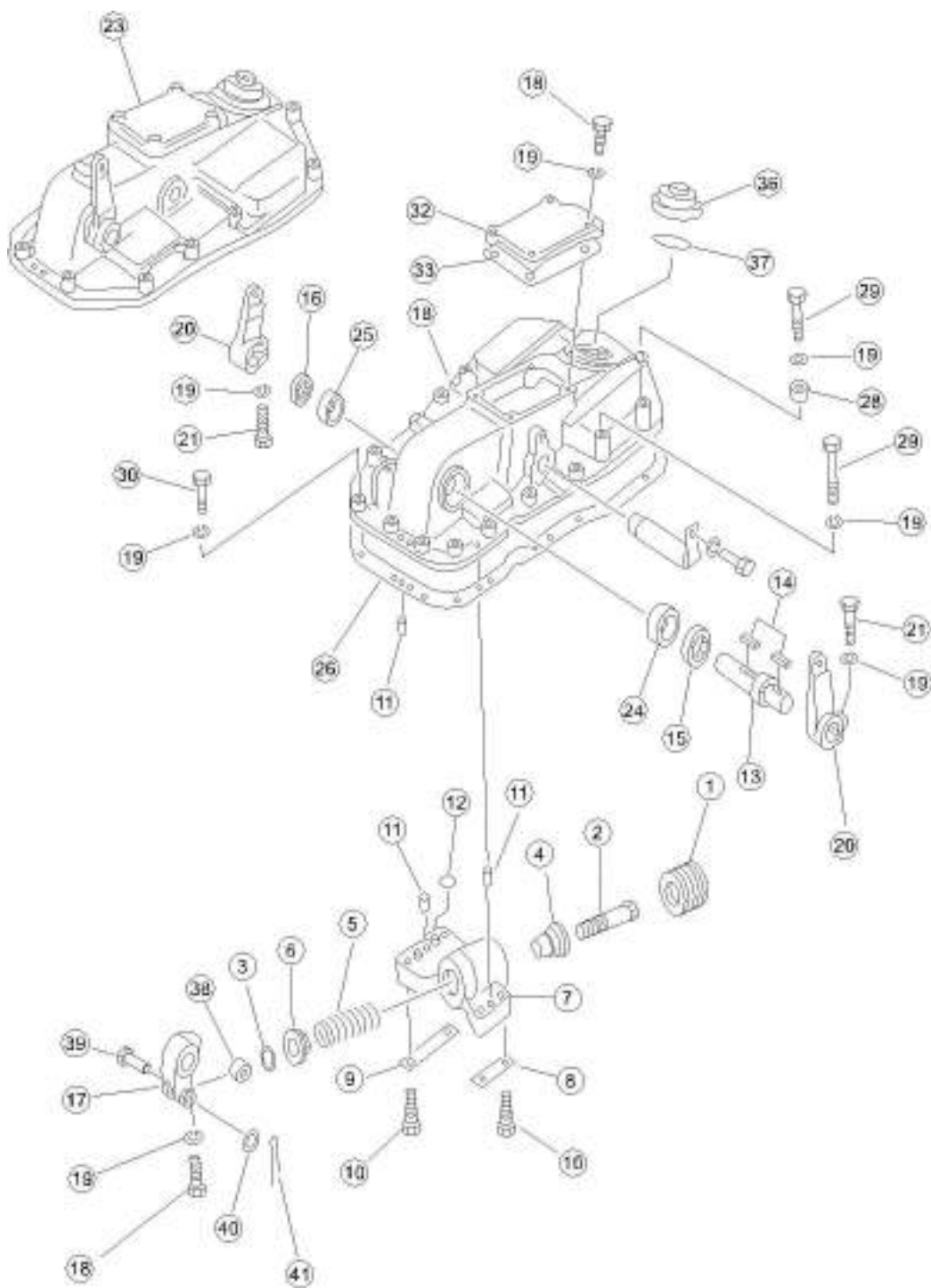

序号 NO.	部件号 PART NO.	零件名称 PART NAME	数量 Q'TY	适用机型 MODEL
1	175-33-28330	活塞 Piston	2	
2	175-33-24441	轴 Shaft	2	
3	04064-12512	挡圈 Retainer ring	4	
4	195-33-14341	衬套 Bushing	2	
5	170-33-13370	弹簧 Spring	2	
6	175-33-31310	锁板 Lock plate	2	
7	175-33-28310	左阀体 L.H. Valve body	1	
7	175-33-28320	右阀体 R.H. Valve body	1	
8	154-33-21420	锁片 Locking plate	2	
9	154-33-21430	锁片 Locking plate	2	
10	01010-51255	螺栓 M12*55 Bolt M12*55	8	
11	04020-01228	圆柱销 Cylindrical pin	8	
12	07000-12020	O形圈 O-ring	4	
13	154-33-21310	轴 Shaft	1	
13	175-33-26130	轴 Shaft	1	
14	04000-01030	平键 Flat key	4	
15	154-33-21340	油封 Oil seal	2	
16	154-33-21350	油封 Oil seal	2	
17	154-33-21150	摇臂 Rock arm	2	
18	01010-51235	螺栓 M12*35 Bolt M12*35	10	
19	01602-21236	垫圈 12 Washer 12	46	
20	175-33-25991	杆 Lever	1	
20	175-33-26110	杆 Lever	1	
21	01010-51245	螺栓 M12*45 Bolt M12*45	2	
23	175-33-24378	左盖 Cover (L.H.)	1	
23	175-33-24388	右盖 Cover (R.H.)	1	
24	154-33-21320	轴套 Sleeve	2	
25	154-33-21330	轴套 Sleeve	2	
26	175-33-24415	垫片 Shim	2	
28	195-33-11220	隔套 Spacer	6	
29	01010-51280	螺栓 M12*80 Bolt M12*80	4	
30	01010-51260	螺栓 M12*60 Bolt M12*60	30	
32	175-33-24361	端盖 End cover	2	
33	175-33-24511	垫片 Shim	2	
36	154-33-21142	盖 Cover	2	
37	07000-12095	O形圈 O-ring	2	
38	170-33-13330	滚子 Roller	2	
39	04205-01645	销轴 Pin shaft	2	
40	01641-21626	垫圈 16 Washer 16	2	
41	04050-14026	开口销 Cotter pin	2	

### 转向控制杆 STEERING CONTROL LEVER

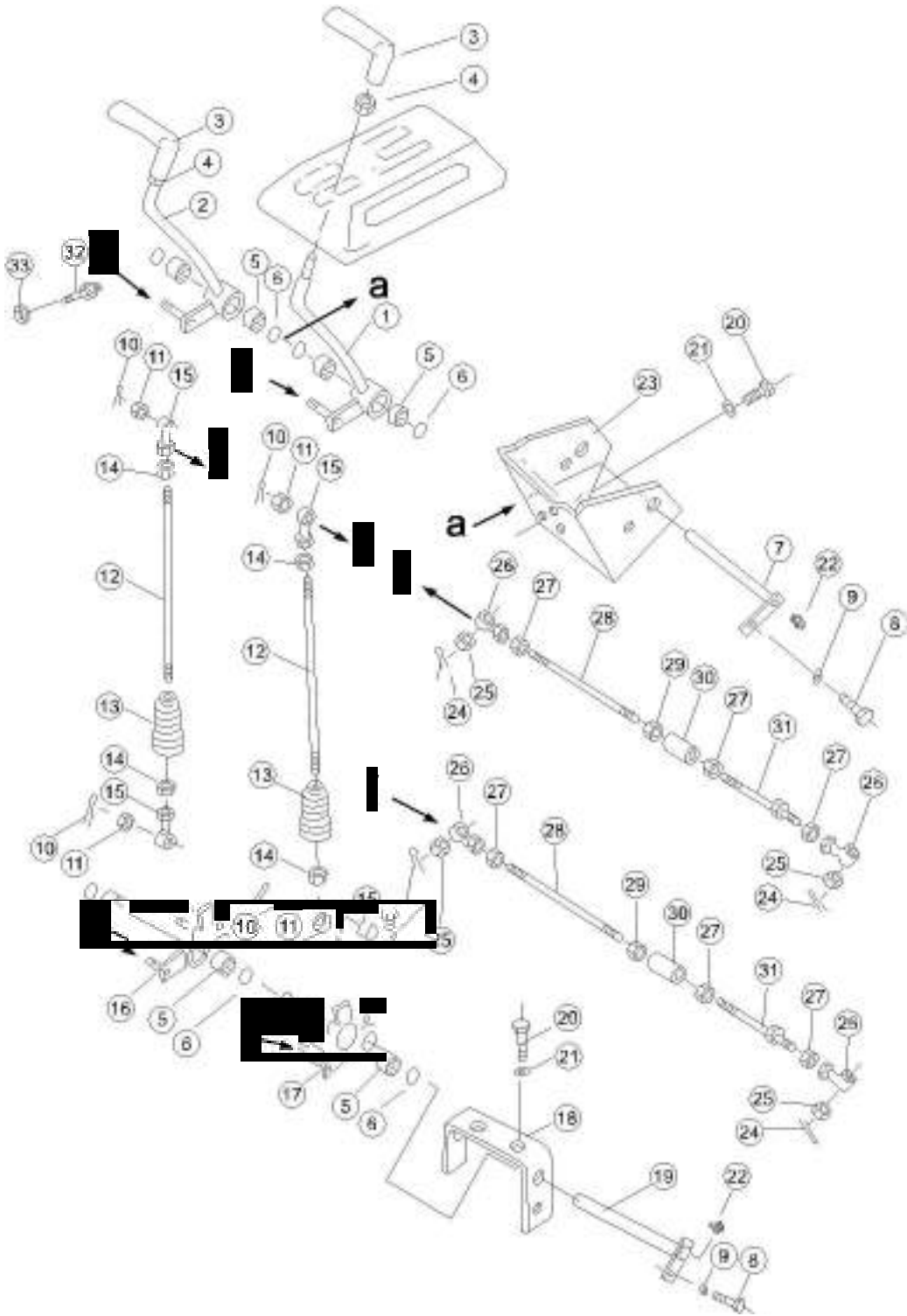

序号 NO.	部件号 PART NO.	零件名称 PART NAME		数量 Q'TY	适用机型 MODEL
1	175-43-51111	摇臂 ( 左 )	Rock arm (L.H.)	1	
2	175-43-51121	摇臂 ( 右 )	Rock arm (R.H.)	1	
3	175-43-51131	手柄	Handle	2	
4	175-43-51180	螺母	Nut	2	
5	GB290-HK2016	冲压外圈滚针轴承	Needle roller bearing	8	
6	06122-02004	防尘密封圈	Ring, Dust	8	
7	175-43-51211	轴	Shaft	1	
8	01010-51025	螺栓 M10*25	Bolt M10*25	2	
9	01602-21030	垫圈 10	Washer 10	2	
10	04050-12016	开口销	Cotter pin	4	
11	01590-30809	螺母 M8	Nut M8	4	
12	04245-40839	杆	Lever	2	
13	175-43-51220	伸缩软管	Flexible hose	2	
14	01580-10806	螺母 M8	Nut M8	4	
15	113-43-23270	关节轴承	Joint bearing	4	
16	175-43-42640	摇臂	Rock arm	1	
17	175-43-42650	摇臂	Rock arm	1	
18	175-43-51231	支架	Bracket	1	
19	175-43-51241	轴	Shaft	1	
20	01010-51225	螺栓 M12*25	Bolt M12*25	5	
21	01643-31232	垫圈 12	Washer 12	5	
22	07020-00613	油杯 M6	Oil cup M6	2	
23	175-43-51191	板	Plate	1	
24	04050-13030	开口销	Cotter pin	4	
25	01593-31411	螺母 M14*1.5	Nut M14*1.5	4	
26	04250-41474	关节轴承	Joint bearing	4	
27	01582-11411	螺母 M14*1.5	Nut M14*1.5	6	
28	04245-41451	杆	Lever	2	
29	01508-41408	螺母 M14*1.5 左	Nut (L.H.) M14*1.5	2	
30	154-44-21650	螺套	Sleeve, Bolt	2	
31	04248-31452	杆	Lever	2	
32	09311-41237	缓冲螺栓	Bolt	2	
33	01580-11210	螺母	Nut	2	

# 制动踏板 BRAKE PEDAL

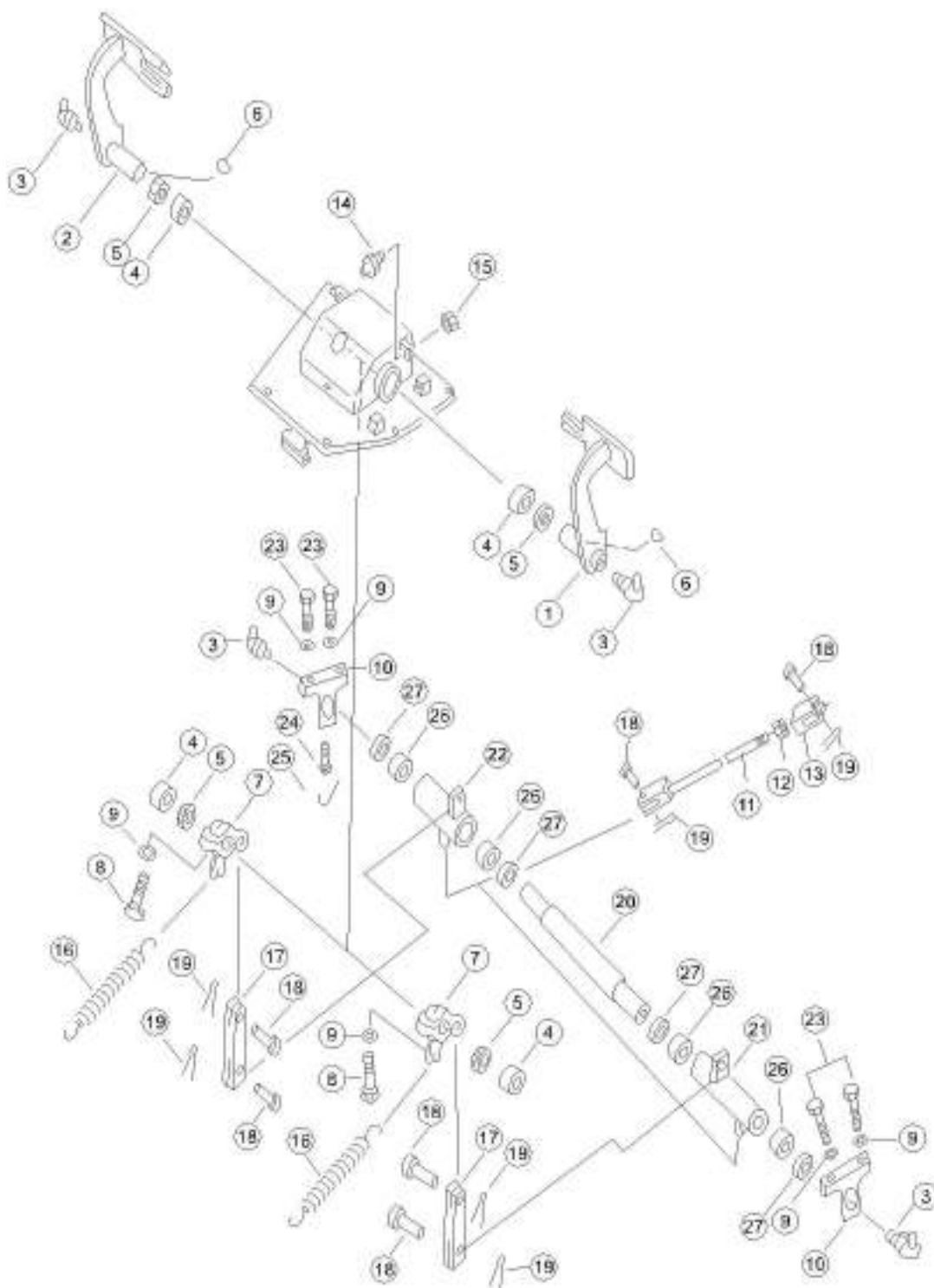

序号 NO.	部件号 PART NO.	零件名称 PART NAME		数量 Q'TY	适用机型 MODEL
1	16Y-26C-01000	踏板 ( 左 )	Pedal (L.H.)	1	
2	16Y-26C-02000	踏板 ( 右 )	Pedal (R.H.)	1	
3	07021-01090	油杯 90° M10*1	Oil cup 90° M10*1	4	
4	GB290-HK3520	冲压外圈滚针轴承	Needle roller bearing	4	
5	06122-03504	防尘密封圈	Ring, Dust	4	
6	04010-11032	半圆键	Woodruff Key	2	
7	10Y-26-13000	摇臂	Rock arm	2	
8	01010-51235	螺栓 M12*35	Bolt M12*35	2	
9	01643-31232	垫圈 12	Washer 12	6	
10	10Y-26-00003	支架	Bracket	2	
11	04244-41413	杆组件	Lever ass'y	2	
12	01580-31411	螺母	Nut	2	
13	04210-21456	叉口板	Fork plate	2	
14	09311-41237	缓冲螺栓	Bolt	2	
15	01580-11210	螺母	Nut	2	
16	154-43-41260	弹簧	Spring	2	
17	10Y-26-00004	接头	Nipple	2	
18	04205-11440	销轴	Pin shaft	8	
19	04050-14022	开口销	Cotter pin	8	
20	171-26-00002	轴	Shaft	1	
21	171-26-01000	摇臂 ( 左 )	Rock arm (L.H.)	1	
22	171-26-02000	摇臂 ( 右 )	Rock arm (R.H.)	1	
23	01010-51225	螺栓 M12*25	Bolt M12*25	4	
24	04059-01010	铁丝	Iron wire	1	
25	01306-10616	螺钉 M6*16	Screw M6*16	1	
26	GB290-HK3020	冲压外圈滚针轴承	Needle roller bearing	4	
27	06122-03004	防尘密封圈	Ring, Dust	4	

# 制动连杆 BRAKE LINKAGE

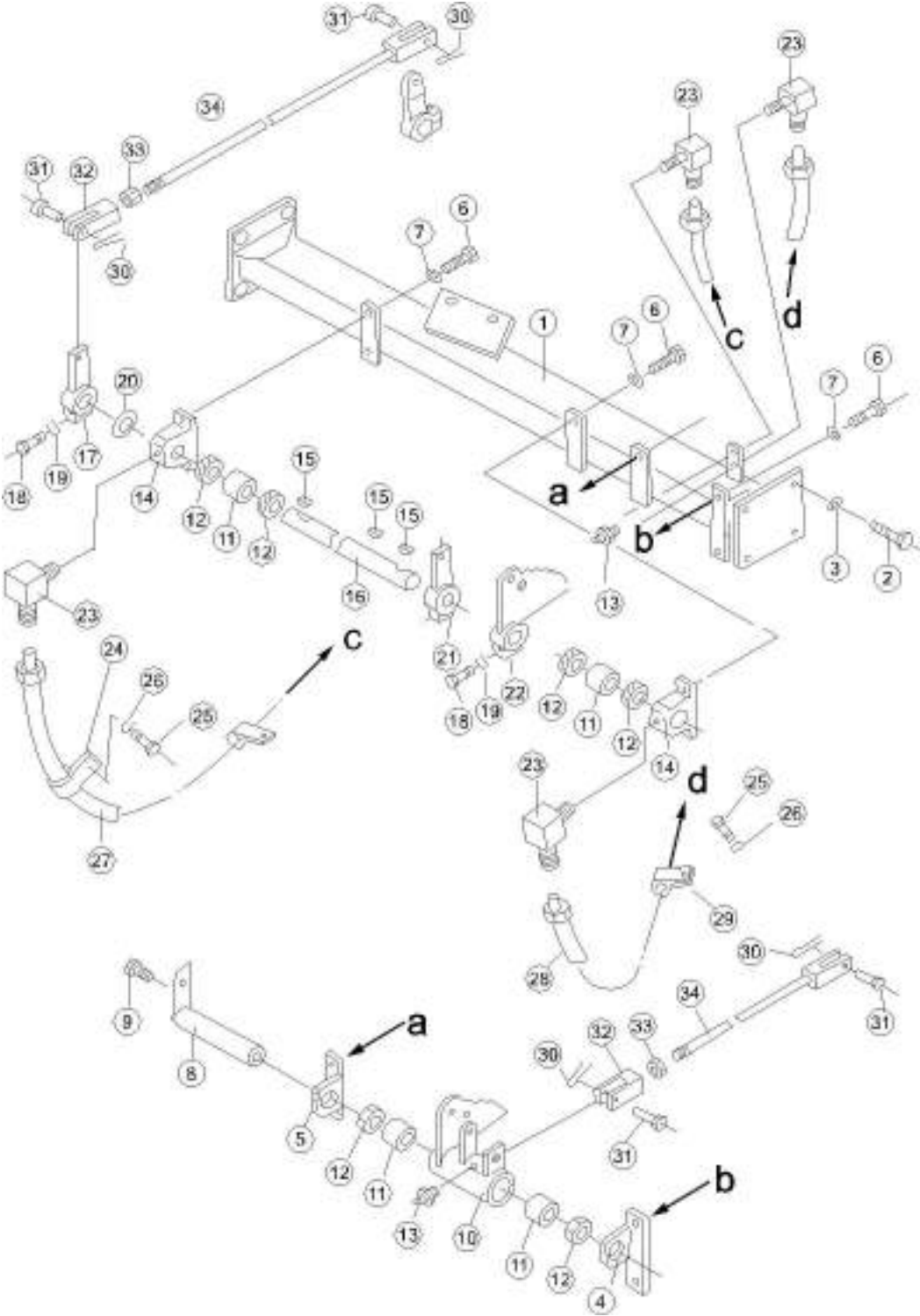

序号 NO.	部件号 PART NO.	零件名称 PART NAME		数量 Q'TY	适用机型 MODEL
1	175-43-42272	托架	Bracket	1	
2	01010-51645	螺栓 M16*45	Bolt M16*45	8	
3	01643-31645	垫圈 16	Washer 16	8	
4	195-43-24621	支座 (左)	Seat (L.H.)	1	
5	195-43-24631	支座 (右)	Seat (R.H.)	1	
6	01010-51230	螺栓 M12*30	Bolt M12*30	8	
7	01643-31232	垫圈 12	Washer 12	8	
8	195-43-24321	轴	Shaft	1	
9	01010-50816	螺栓 M8*16	Bolt M8*16	1	
10	171-26-04000	棘轮 (左)	Ratchet wheel (L.H.)	1	
11	GB290-HK3520	冲压外圈滚针轴承	Needle roller bearing	4	
12	06122-03504	防尘密封圈	Ring, Dust	6	
13	07020-01021	油杯 M10*1	Oil cup M10*1	3	
14	195-43-24391	支座	Seat	2	
15	04010-11032	半圆键	Woodruff Key	2	
16	171-26-00001	轴	Shaft	1	
17	154-43-15581	摇臂	Rock arm	1	
18	01010-51245	螺栓 M12*45	Bolt M12*45	2	
19	01602-21236	垫圈 12	Washer 12	2	
20	195-43-24430	隔垫	Shield	1	
21	171-26-05000	摇臂	Rock arm	1	
22	171-26-03000	棘轮 (右)	Ratchet wheel (R.H.)	1	
23	176-43-41350	弯管接头	Elbow	4	
24	08036-10814	线夹	Wire clip	2	
25	01010-51016	螺栓 M10*16	Bolt M10*16	3	
26	01643-31032	垫圈 10	Washer 10	3	
27	175-43-42720	管	Tube	1	
28	175-43-42710	管	Tube	1	
29	08036-11214	线夹	Wire clip	1	
30	04050-14026	开口销	Cotter pin	4	
31	04205-11438	销轴	Pin shaft	4	
32	04211-21478	叉口板	Fork plate	2	
33	01582-11411	螺母 M14*1.5	Nut M14*1.5	2	
34	04244-51486	杆组件	Lever ass'y	2	

# 停车制动 PARKING BRAKE

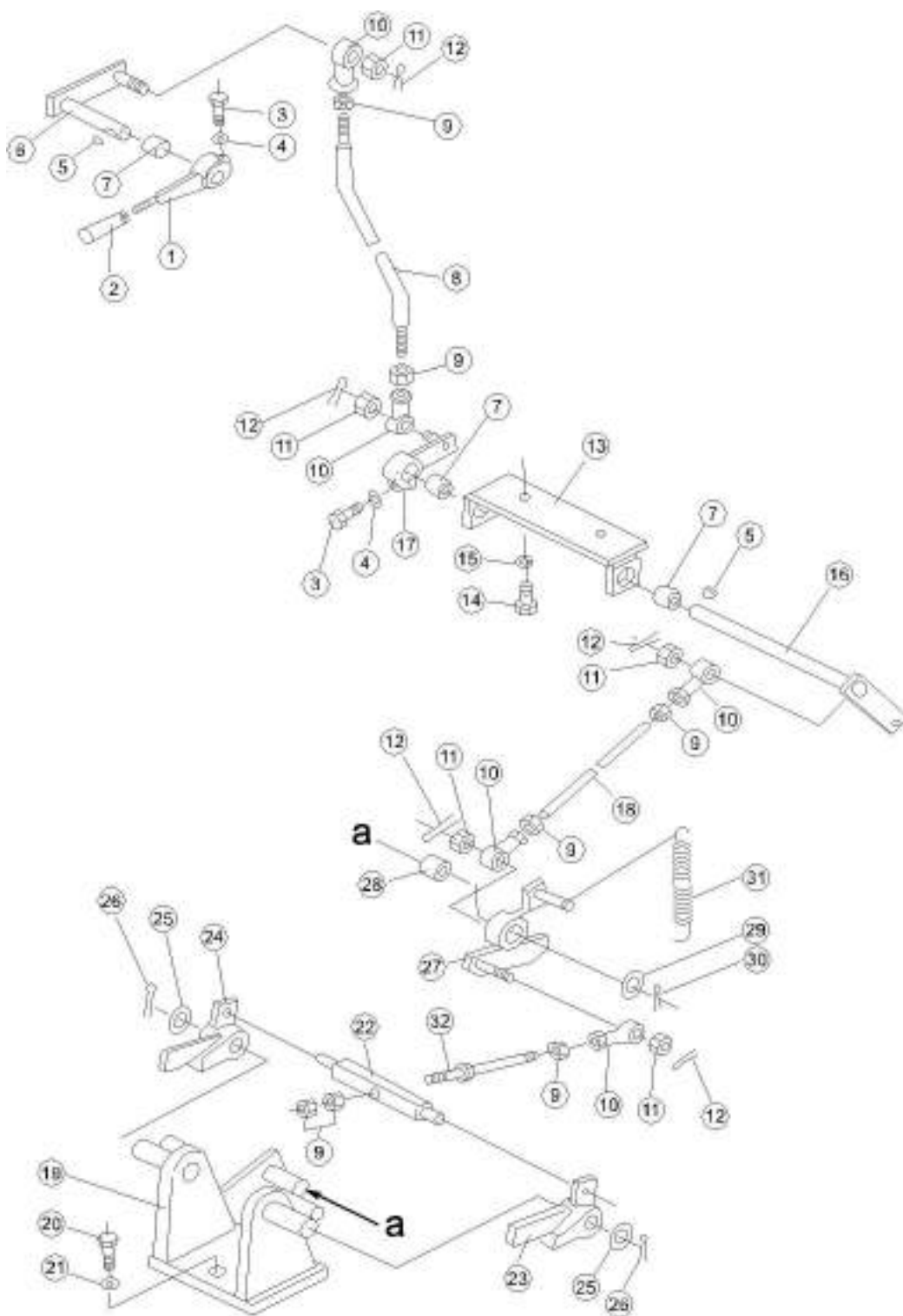

序号 NO.	部件号 PART NO.	零件名称 PART NAME		数量 Q'TY	适用机型 MODEL
1	195-43-24560	支杆	Support bar	1	
2	09305-00800	手柄	Handle	1	
3	01010-50830	螺栓 M8*30	Bolt M8*30	2	
4	01602-20825	垫圈 8	Washer 8	2	
5	04010-10516	半圆键	Woodruff Key	2	
6	195-43-24551	摇臂	Rock arm	1	
7	09350-01615	轴套	Sleeve	4	
8	195-43-24541	杆	Lever	1	
9	01580-10806	螺母 M8	Nut M8	7	
10	04250-40847	关节轴承	Joint bearing	5	
11	01590-30809	螺母 M8	Nut M8	5	
12	04050-12016	开口销	Cotter pin	5	
13	171-26-07000	支座	Seat	1	
14	01010-51230	螺栓 M12*30	Bolt M12*30	2	
15	01643-31232	垫圈 12	Washer 12	2	
16	171-26-06000	摇臂	Rock arm	1	
17	175-43-41382	摇臂	Rock arm	1	
18	04245-40823	杆	Lever	1	
19	175-43-41452	支架	Bracket	1	
20	01010-51640	螺栓 M16*40	Bolt M16*40	2	
21	01643-31645	垫圈 16	Washer 16	2	
22	195-43-21940	小轴	Small shaft	1	
23	195-43-24471	棘爪 (左)	Detent (L.H.)	1	
24	195-43-24481	棘爪 (右)	Detent (R.H.)	1	
25	01640-22032	垫圈 20	Washer 20	2	
26	04050-14028	开口销	Cotter pin	2	
27	175-43-41413	摇臂	Rock arm	1	
28	195-43-12640	衬套	Bushing	1	
29	01641-21626	垫圈 16	Washer 16	1	
30	04050-14026	开口销	Cotter pin	1	
31	103-33-11260	弹簧	Spring	1	
32	195-43-24491	杆	Lever	1	

# 转向油泵 STEERING PUMP

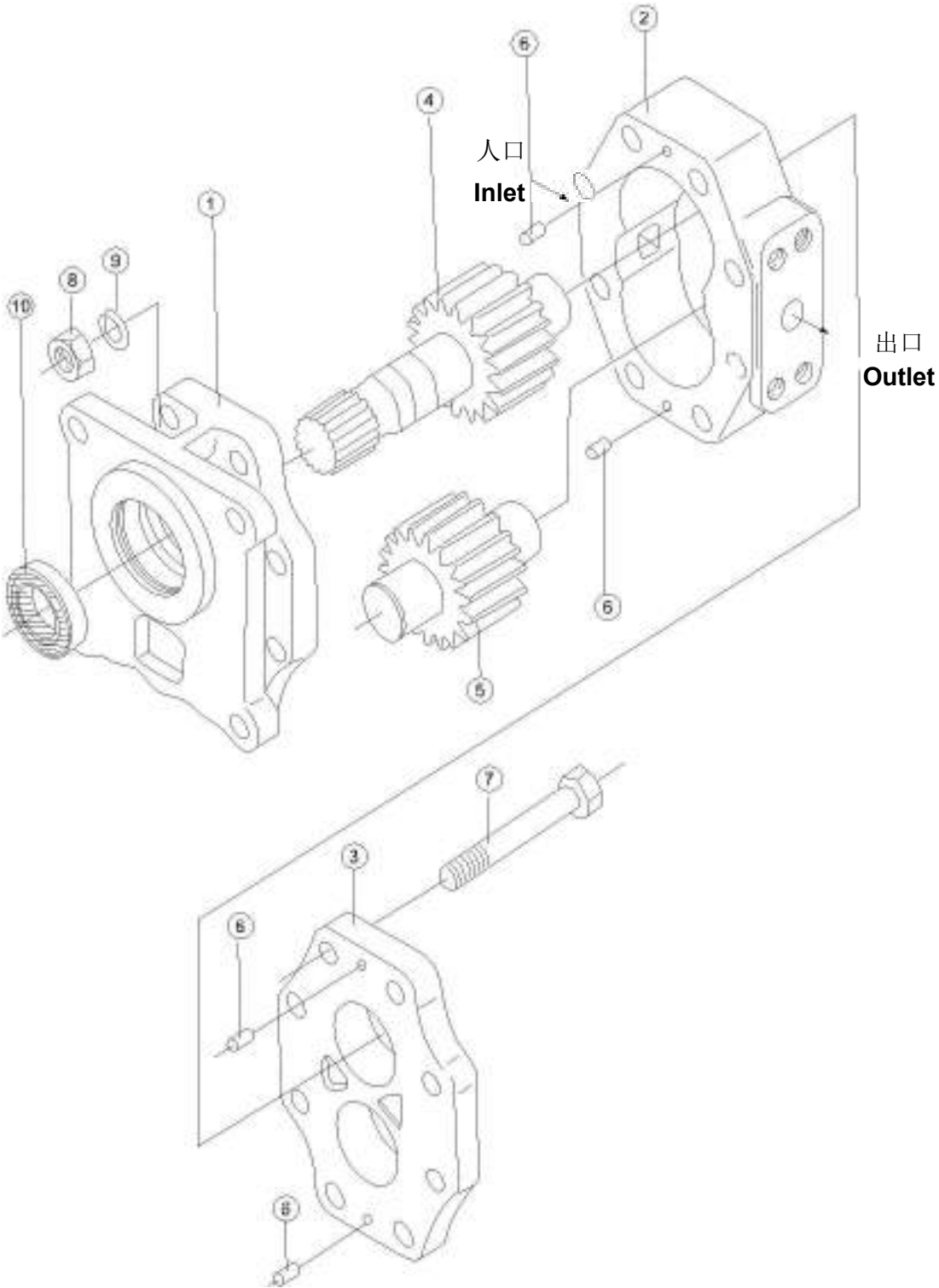

序号 NO.	部件号 PART NO.	零件名称 PART NAME		数量 Q'TY	适用机型 MODEL
1	07438-72111	托架总成	Bracket ass'y	1	
2	07440-71221	泵体	Body, Pump	1	
3	07433-71131	泵盖组件	Cover, Pump	1	
4	07440-71042	主动齿轮	Driving gear	1	
5	07440-71052	被动齿轮	Driven gear	1	
6	04020-00820	圆柱销	Cylindrical pin	4	
7	01051-51420	螺栓 M14*1.5*120	Bolt M14*1.5*120	8	
8	01582-11411	螺母 M14*1.5	Nut M14*1.5	8	
9	01602-21442	垫圈 14	Washer 14	8	
10	07438-71160	油封	Oil seal	1	

### 粗滤器总成 COARSE STRAINER ASS'Y

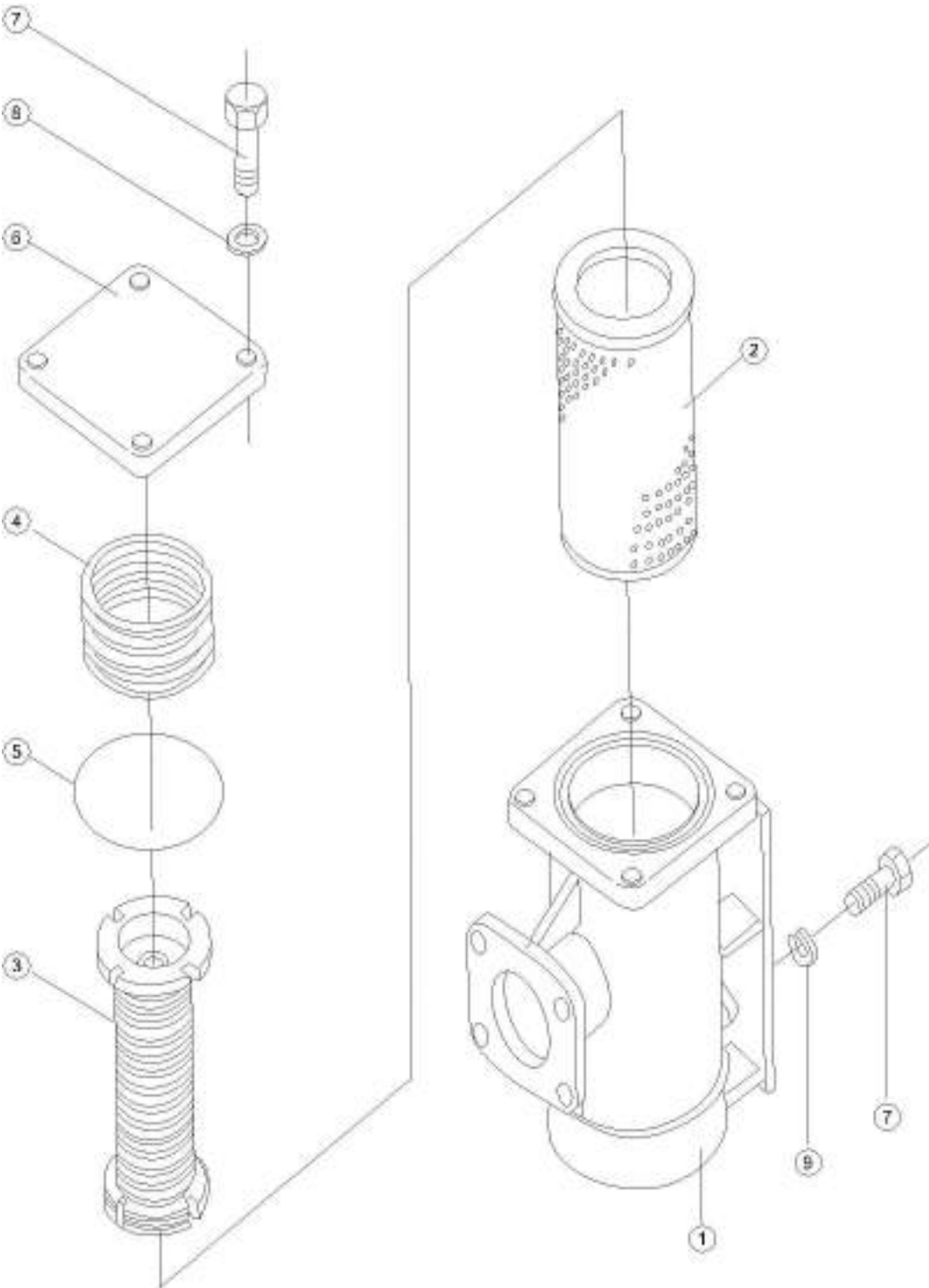

序号 NO.	部件号 PART NO.	零件名称 PART NAME		数量 Q'TY	适用机型 MODEL
1	175-49-22281	箱体	Box body	1	
2	175-49-11222	滤网	Filter screen	1	
3	175-49-11231	磁铁总成	Magnet ass'y	1	
4	154-19-11230	弹簧	Spring	1	
5	07000-13130	O 形圈	O-ring	1	
6	175-49-21690	盖	Cover	1	
7	01010-51235	螺栓 M12*35	Bolt M12*35	8	
8	01602-21236	垫圈 12	Washer 12	4	
9	01643-31232	垫圈 12	Washer 12	4	

# 转向阀 STEERING VALVE

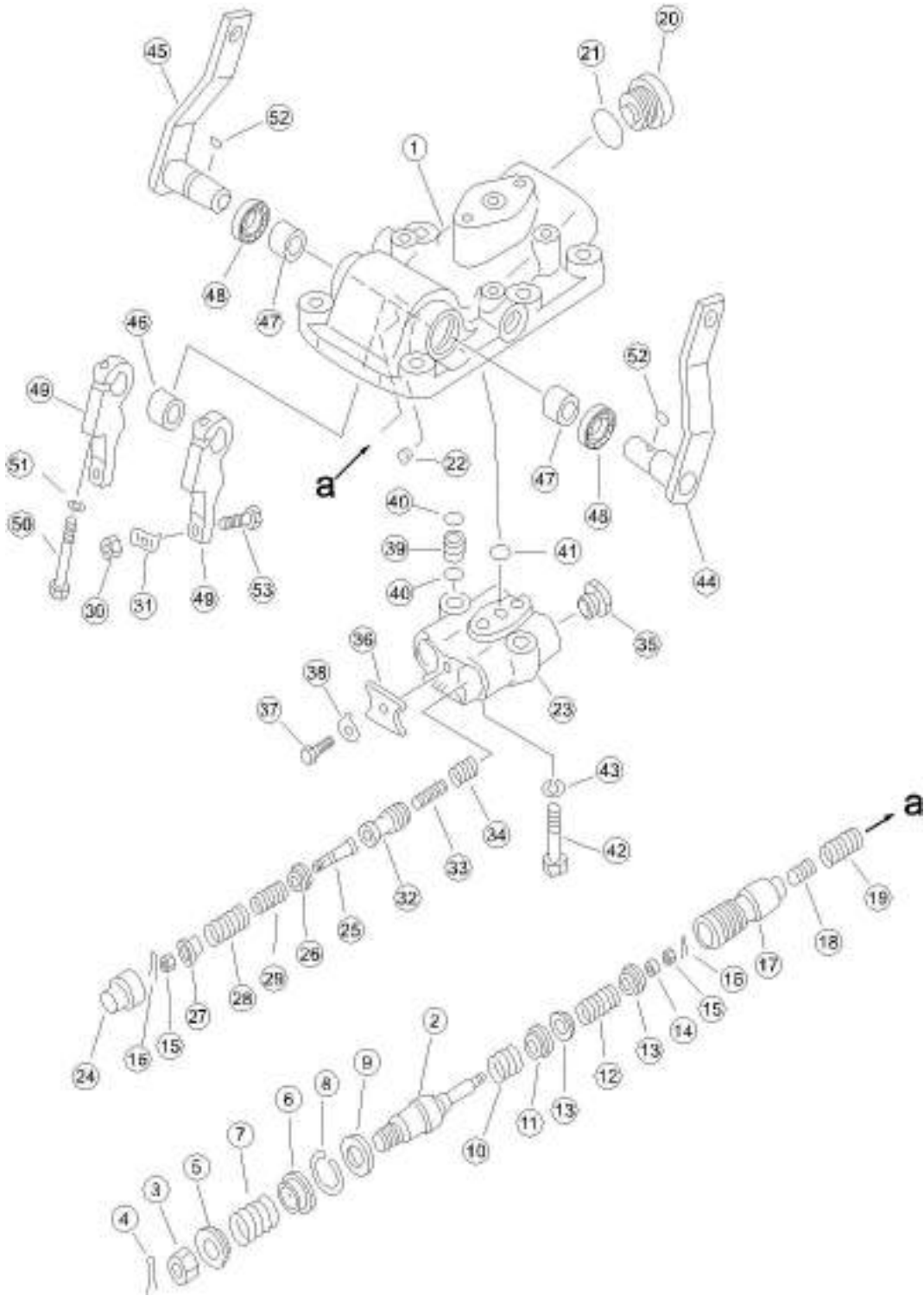

序号 NO.	部件号 PART NO.	零件名称 PART NAME		数量 Q'TY	适用机型 MODEL
1	144-40-22211	阀体	Valve body	1	
2	195-40-11540	轴	Shaft	2	
3	01593-31613	螺母 M16*1.5	Nut M16*1.5	2	
4	04050-14026	开口销	Cotter pin	2	
5	144-40-22180	座	Seat	2	
6	144-40-22170	座	Seat	2	
7	175-40-31230	弹簧	Spring	2	
8	04065-03212	挡圈	Retainer ring	2	
9	195-40-13110	挡圈	Retainer ring	2	
10	195-40-11550	弹簧	Spring	2	
11	195-40-11560	座	Seat	2	
12	175-40-31150	弹簧	Spring	2	
13	195-40-11570	座	Seat	2	
14	144-40-22190	垫圈	Washer	2	
15	01590-30607	螺母 M6	Nut M6	4	
16	04050-11212	开口销	Cotter pin	4	
17	195-40-11531	阀芯	Valve core	2	
18	702-11-11190	活塞	Piston	2	
19	175-40-31130	弹簧	Spring	2	
20	175-40-31530	螺塞	Screw plug	2	
21	07002-13034	O 形圈	O-ring	2	
22	07043-70108	螺塞	Screw plug	1	
23	144-40-22230	阀体	Valve body	1	
24	144-40-22290	导套	Sleeve, Guide	2	
25	144-40-22260	轴	Shaft	2	
26	144-40-22270	座	Seat	2	
27	144-40-22280	座	Seat	2	
28	144-40-22340	弹簧	Spring	2	
29	154-40-41130	弹簧	Spring	2	
30	01580-10806	螺母 M8	Nut M8	2	
31	130-21-12330	锁片	Locking plate	2	
32	144-40-22311	阀芯	Valve core	2	
33	144-40-22320	活塞	Piston	2	
34	175-40-31410	弹簧	Spring	2	
35	144-40-22250	螺塞	Screw plug	2	
36	144-40-22330	板	Plate	1	
37	01010-50816	螺栓 M8*16	Bolt M8*16	1	

# 转向阀 STEERING VALVE

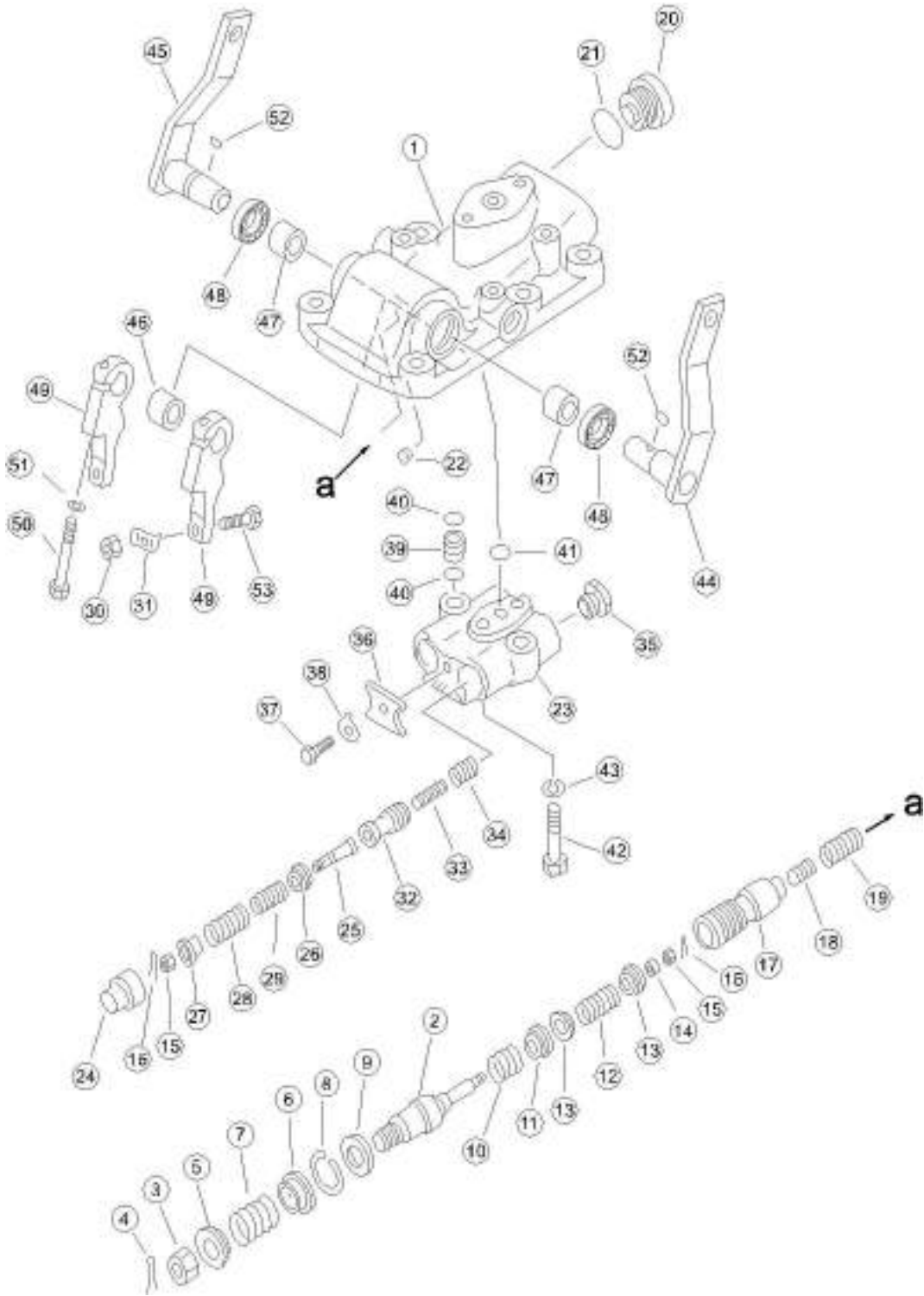

序号 NO.	部件号 PART NO.	零件名称 PART NAME		数量 Q'TY	适用机型 MODEL
38	01650-20808	垫片 8	Shim 8	1	
39	175-40-31510	导管	Tube	2	
40	07000-12011	O 形圈	O-ring	4	
41	07000-12015	O 形圈	O-ring	1	
42	01010-51050	螺栓 M10*50	Bolt M10*50	2	
43	01602-21030	垫圈 10	Washer 10	2	
44	195-40-11590	操纵杆	Control lever	1	
45	195-40-11610	操纵杆	Control lever	1	
46	09350-01820	轴套	Sleeve	1	
47	09350-02215	轴套	Sleeve	2	
48	175-40-31270	油封	Oil seal	2	
49	144-40-22240	杆	Lever	2	
50	01010-50860	螺栓 M8*60	Bolt M8*60	2	
51	01602-20825	垫圈 8	Washer 8	2	
52	04010-00416	半圆键	Woodruff Key	2	
53	144-40-22160	螺栓	Bolt	2	

# 安全阀 SAFETY VALVE

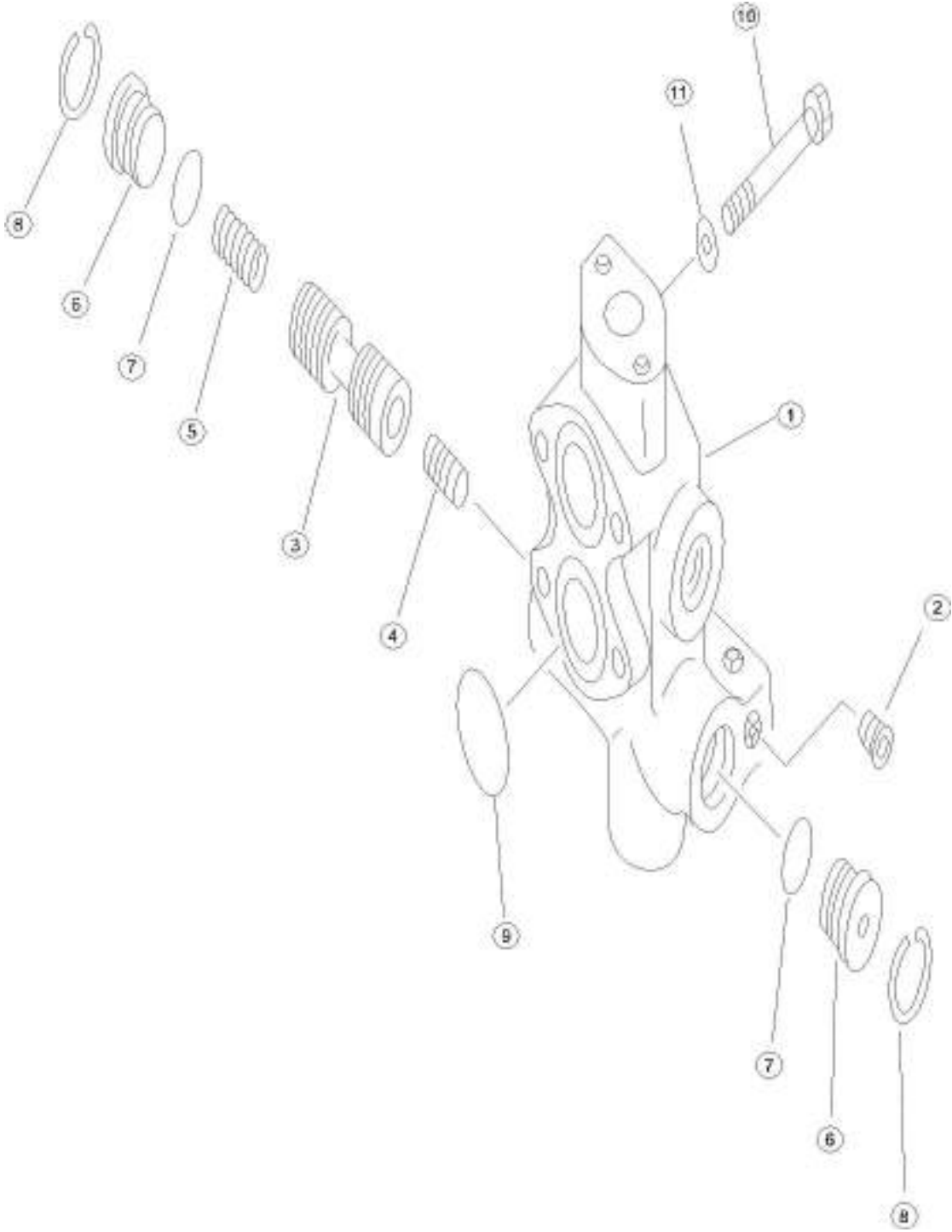

序号 NO.	部件号 PART NO.	零件名称 PART NAME		数量 Q'TY	适用机型 MODEL
1	195-49-13750	阀体	Valve body	1	
2	07043-70108	螺塞	Screw plug	1	
3	145-14-23710	阀芯	Valve core	1	
4	145-14-23720	柱塞	Plunger	1	
5	195-40-11431	弹簧	Spring	1	
6	170-33-13530	堵	Plug	2	
7	07000-13025	O 形圈	O-ring	2	
8	04065-03515	挡圈	Retainer ring	2	
9	07000-13042	O 形圈	O-ring	2	
10	01010-51085	螺栓 M10*85	Bolt M10*85	4	
11	01602-21030	垫圈 10	Washer 10	4	

### 制动管路系统 BRAKE PIPING SYSTEM

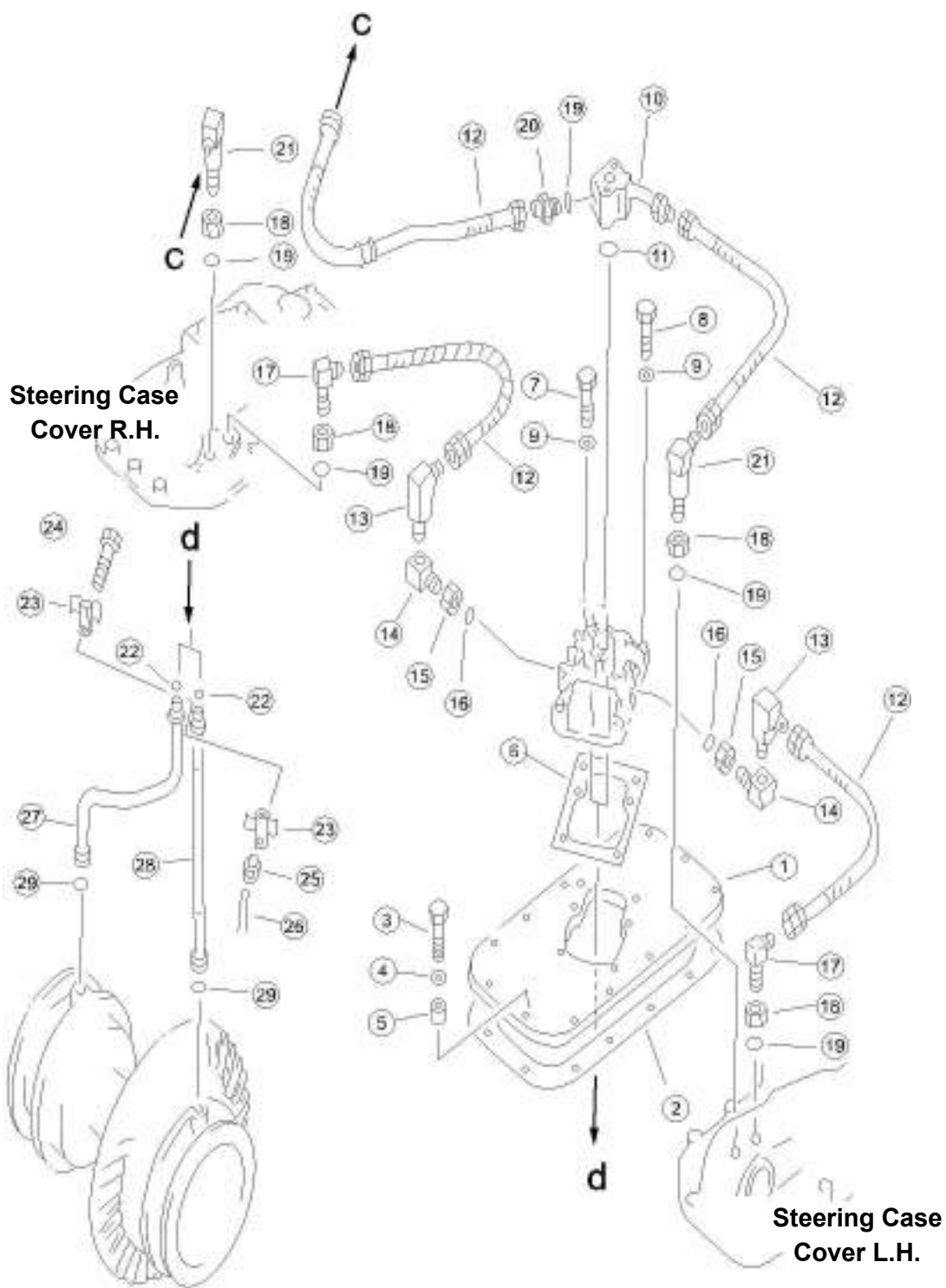

序号 NO.	部件号 PART NO.	零件名称 PART NAME	数量 Q'TY	适用机型 MODEL
1	175-49-23460	板 Plate	1	
2	175-40-22521	垫 Pad	1	
3	01010-51260	螺栓 M12*60 Bolt M12*60	13	
4	01602-21236	垫圈 12 Washer 12	13	
5	195-33-11220	隔套 Spacer	13	
6	144-40-22220	密封垫 GASKET	1	
7	01010-51240	螺栓 M12*40 Bolt M12*40	1	
8	01010-51250	螺栓 M12*50 Bolt M12*50	5	
9	01643-31232	垫圈 12 Washer 12	6	
10	175-33-23470	管 Tube	1	
11	07000-13028	O 形圈 O-ring	1	
12	07102-20303	软管 Hose	4	
13	203-62-12330	弯管接头 Elbow	2	
14	195-49-13830	管接头 Nipple	2	
15	195-49-13840	螺母 Nut	2	
16	07002-11623	O 形圈 O-ring	2	
17	07232-10315	接头 Nipple	4	
18	07239-12009	螺母 Nut	4	
19	07002-12034	O 形圈 O-ring	5	
20	07230-20315	管接头 Nipple	1	
21	175-49-25670	弯管接头 Elbow	2	
22	07000-12018	O 形圈 O-ring	2	
23	175-40-22461	夹子 Clamp	2	
24	01012-51035	螺栓 M10*35 Bolt M10*35	1	
25	01590-31012	螺母 M10 Nut M10	1	
26	04050-12018	开口销 Cotter pin	1	
27	175-40-22580	管 Tube	1	
28	175-40-22570	管子 Tube	1	
29	07000-13022	O 形圈 O-ring	2	
30	175-49-C1221	管子 Tube	1	
31	01010-51075	螺栓 M10*75 Bolt M10*75	2	
33	07000-13040	O 形圈 O-ring	1	
34	07102-20603	软管 Hose	1	
35	07102-21011	软管 Hose	1	
36	07232-11034	接头 Nipple	1	
37	07239-13320	螺母 Nut	2	
38	07002-13334	O 形圈 O-ring	2	

### 制动管路系统 BRAKE PIPING SYSTEM

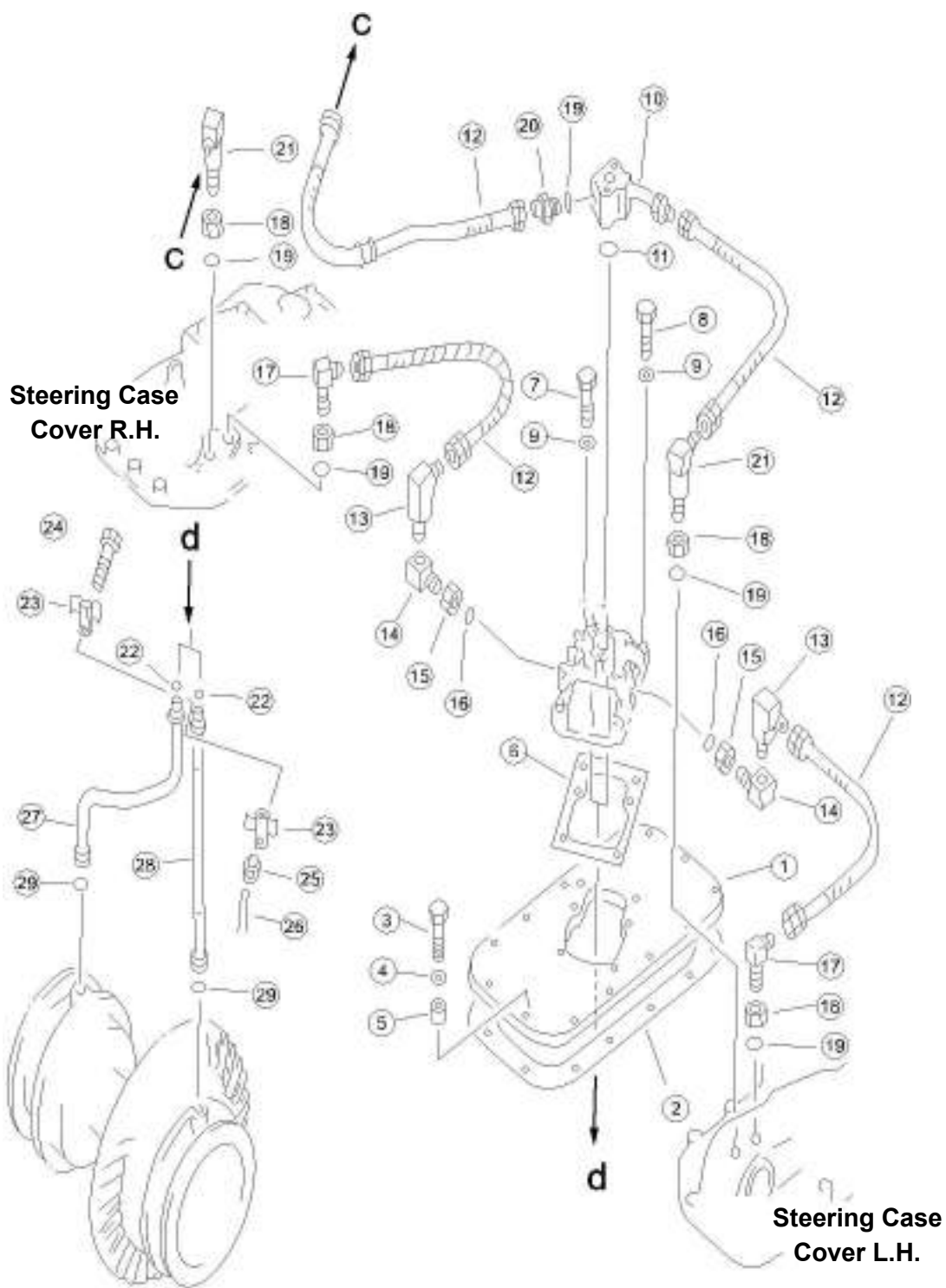

序号 NO.	部件号 PART NO.	零件名称 PART NAME	数量 Q'TY	适用机型 MODEL
40	01010-51055	螺栓 M10*55 Bolt M10*55	2	
42	175-49-21483	管子 Tube	1	
43	07102-20403	软管 Hose	1	
44	175-49-23510	弯头 Elbow	1	
47	01010-50820	螺栓 M8*20 Bolt M8*20	2	
49	07000-13035	O 形圈 O-ring	1	
50	175-49-25680	管子 Tube	1	
51	07281-00549	喉箍 Hose Clamp	2	
52	07260-03213	软管 Hose	1	
53	175-49-21434	管子 Tube	1	

转向管路系统 (1/2)  
**STEERING PIPING SYSTEM (1/2)**

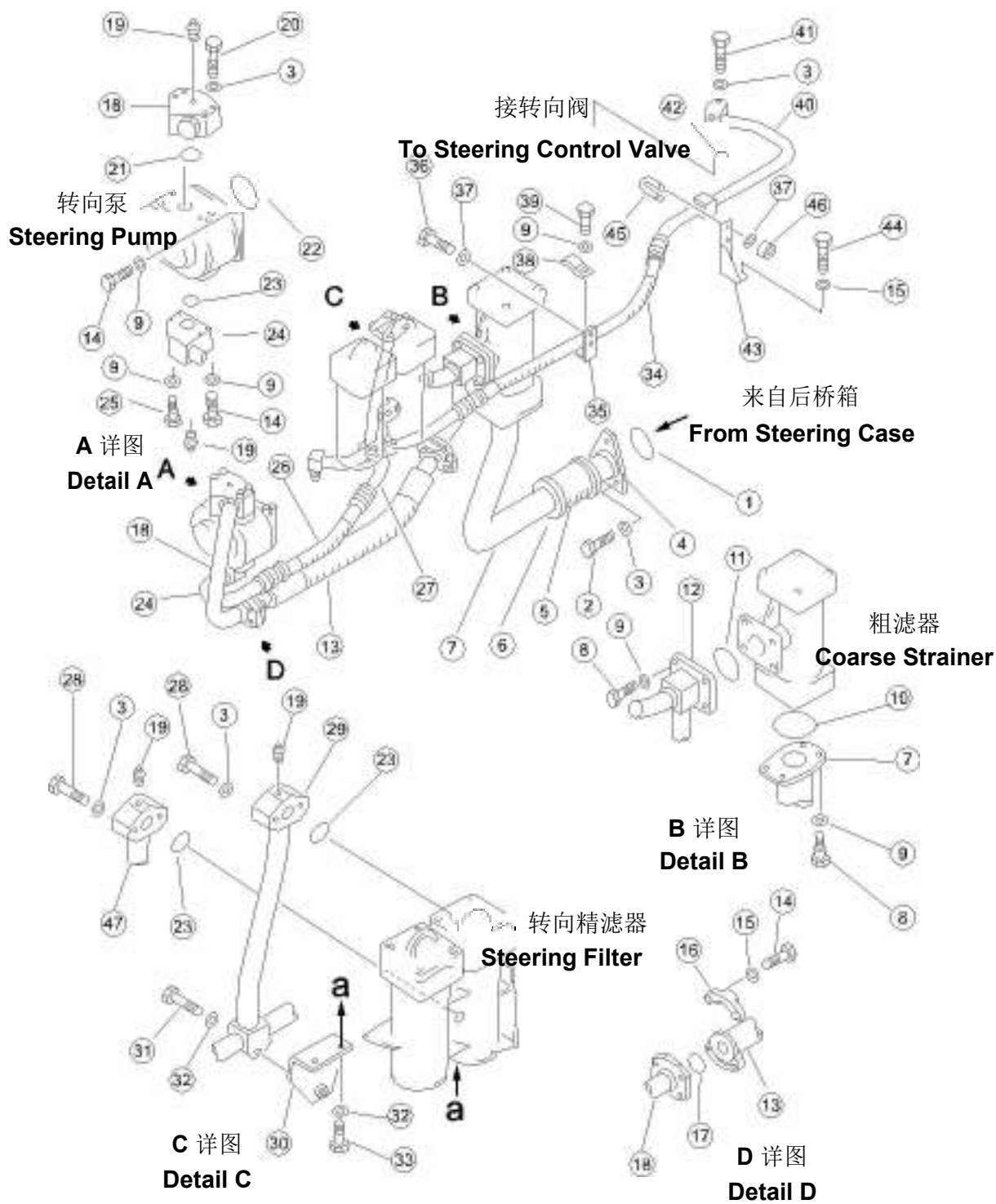

序号 NO.	部件号 PART NO.	零件名称 PART NAME		数量 Q'TY	适用机型 MODEL
1	07000-13090	O 形圈	O-ring	1	
2	01010-51030	螺栓 M10*30	Bolt M10*30	3	
3	01602-21030	垫圈 10	Washer 10	13	
4	175-49-22590	管	Tube	1	
5	24Y-61-01000	软管	Hose	1	
6	07289-00095	管夹	Clip	4	
7	175-49-21112	管子	Tube	1	
8	01010-51235	螺栓 M12*35	Bolt M12*35	8	
9	01602-21236	垫圈 12	Washer 12	17	
10	07000-13080	O 形圈	O-ring	1	
11	07000-13082	O 形圈	O-ring	1	
12	175-49-22113	管子	Tube	1	
13	07119-01408	软管	Hose	1	
14	01010-51240	螺栓 M12*40	Bolt M12*40	14	
15	01643-31232	垫圈 12	Washer 12	9	
16	07371-31465	法兰	Flange	4	
17	07000-13048	O 形圈	O-ring	2	
18	175-49-C1111	管	Tube	1	
19	07042-20108	螺塞	Screw plug	4	
20	01010-51075	螺栓 M10*75	Bolt M10*75	4	
21	07000-13050	O 形圈	O-ring	1	
22	07000-13095	O 形圈	O-ring	1	
23	07000-13035	O 形圈	O-ring	3	
24	175-49-C1132	管子	Tube	1	
25	01010-51275	螺栓 M12*75	Bolt M12*75	2	
26	07102-21011	软管	Hose	1	
27	24G-74-03000	管	Tube	1	
28	01010-51060	螺栓 M10*60	Bolt M10*60	4	
29	24G-74-07000	管	Tube	1	
30	175-49-25690	板	Plate	1	
31	01010-50860	螺栓 M8*60	Bolt M8*60	1	
32	01643-30823	垫圈 8	Washer 8	3	
33	01010-50820	螺栓 M8*20	Bolt M8*20	2	
34	07102-20615	软管	Hose	1	
35	175-49-22212	夹子	Clamp	1	
36	01010-51020	螺栓 M10*20	Bolt M10*20	2	
37	01643-31032	垫圈 10	Washer 10	4	

转向管路系统 (1/2)  
**STEERING PIPING SYSTEM (1/2)**

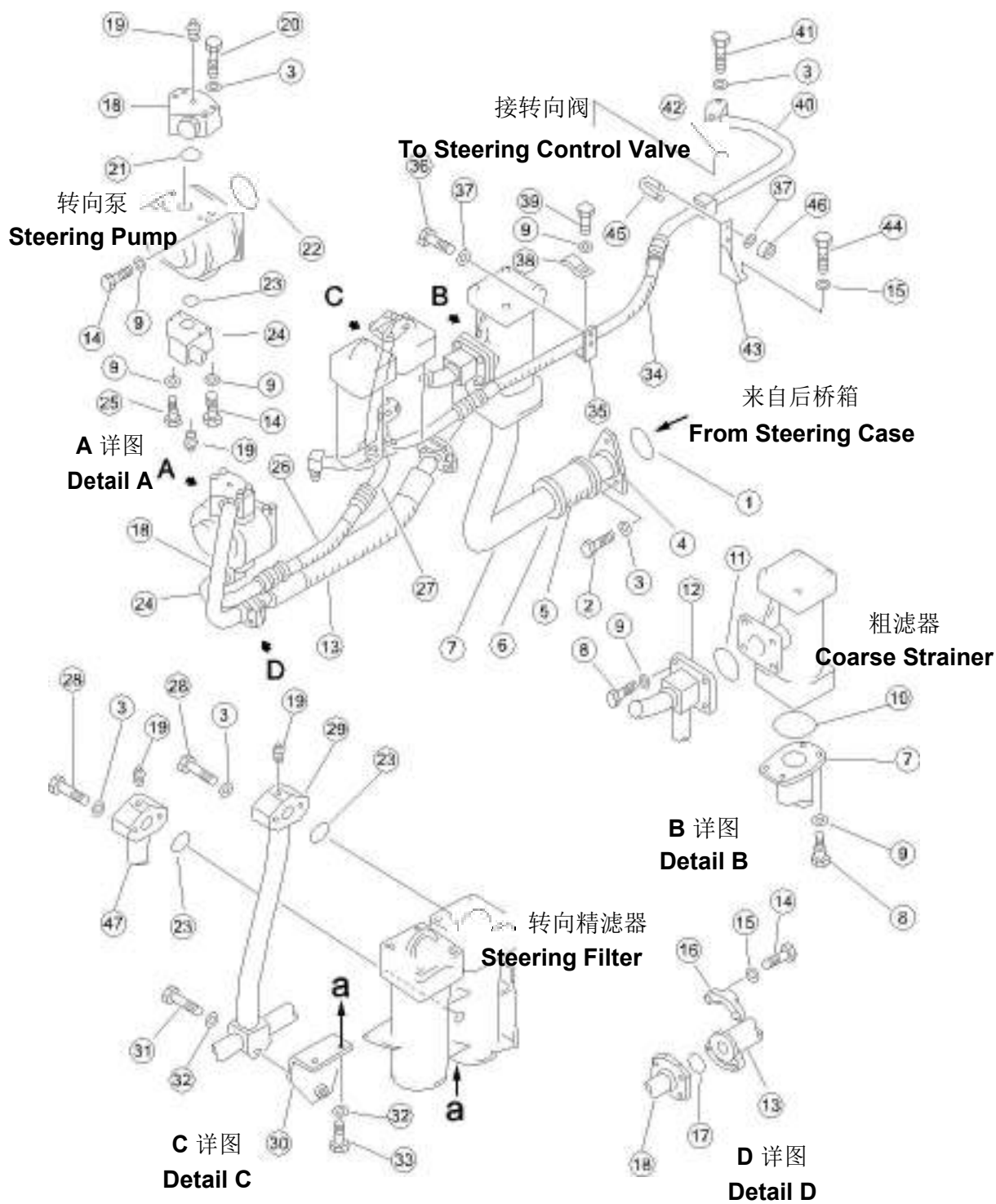

序号 NO.	部件号 PART NO.	零件名称 PART NAME	数量 Q'TY	适用机型 MODEL
38	175-49-41350	夹子 Clamp	1	
39	01010-51230	螺栓 M12*30 Bolt M12*30	1	
40	175-49-22225	管 Tube	1	
41	01011-51020	螺栓 M10*120 Bolt M10*120	2	
42	07000-13028	O 形圈 O-ring	1	
43	175-49-23550	托架 Bracket	1	
44	01010-51270	螺栓 M12*70 Bolt M12*70	1	
45	07283-22738	管夹 Clip	1	
46	01599-01011	螺母 M10*1.25 Nut M10*1.25	2	
47	24G-74-02000	管 Tube	1	

转向管路系统 (2/2)  
STEERING PIPING SYSTEM (2/2)

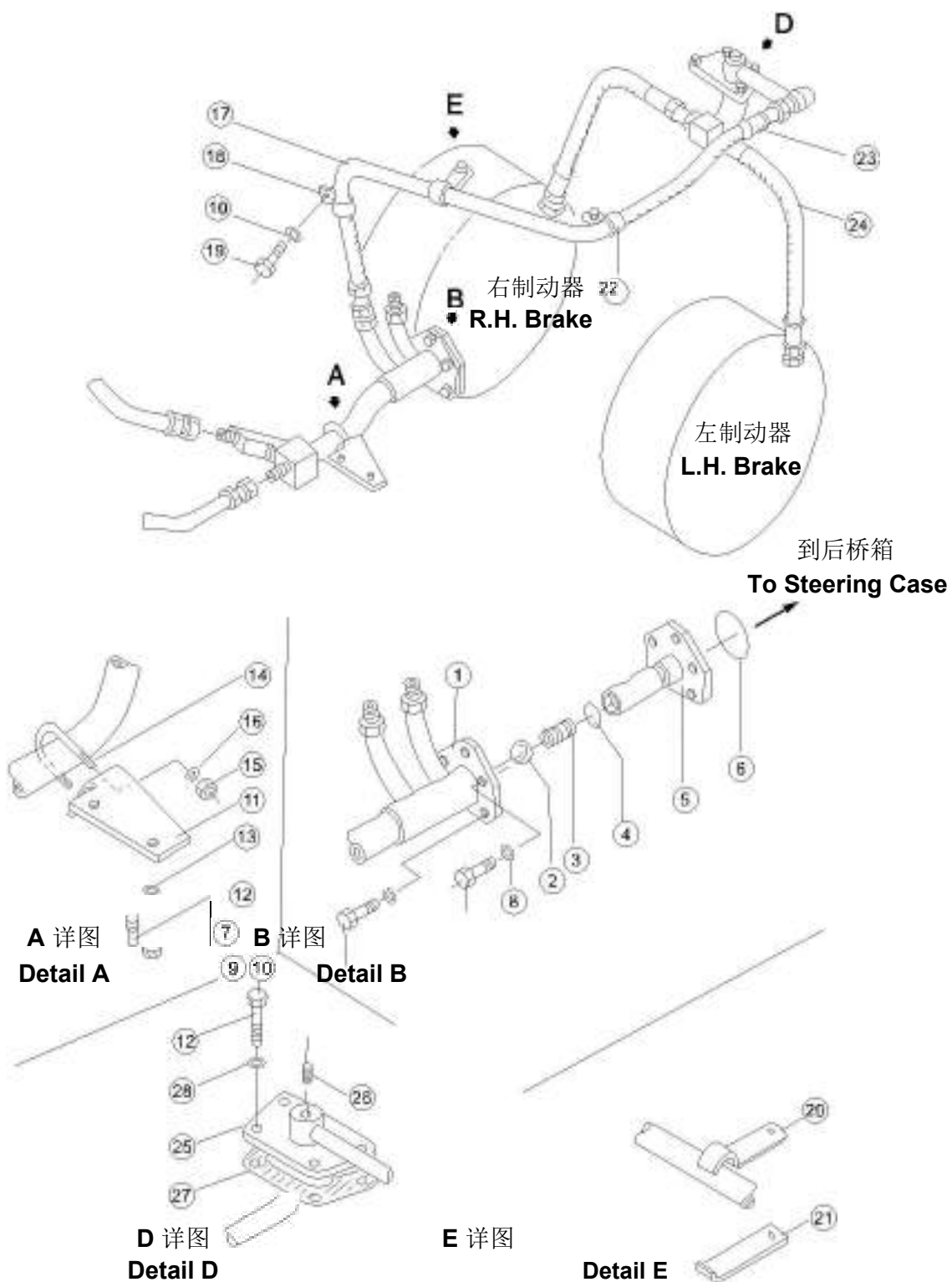

序号 NO.	部件号 PART NO.	零件名称 PART NAME	数量 Q'TY	适用机型 MODEL
1	175-49-23221	管子 Tube	1	
2	04260-02540	钢球 Steel ball	1	
3	175-49-23230	弹簧 Spring	1	
4	07000-13028	O 形圈 O-ring	1	
5	175-49-23211	法兰 Flange	1	
6	07000-12055	O 形圈 O-ring	1	
7	01010-50620	螺栓 M6*20 Bolt M6*20	3	
8	01602-20619	垫圈 6 Washer 6	3	
9	01010-51035	螺栓 M10*35 Bolt M10*35	3	
10	01602-21030	垫圈 10 Washer 10	4	
11	175-49-21510	托架 Bracket	1	
12	01010-51230	螺栓 M12*30 Bolt M12*30	6	
13	01643-31232	垫圈 12 Washer 12	2	
14	07283-24346	管夹 Clip	1	
15	01599-01011	螺母 M10*1.25 Nut M10*1.25	2	
16	01643-31032	垫圈 10 Washer 10	2	
17	07100-20417	软管 Hose	1	
18	175-49-23340	夹子 Clamp	1	
19	01010-51020	螺栓 M10*20 Bolt M10*20	1	
20	175-49-23350	夹子 Clamp	1	
21	175-49-23360	夹子 Clamp	1	
22	08035-02514	线夹 Wire clip	2	
23	175-49-23370	夹子 Clamp	1	
24	175-49-23380	软管 Hose	2	
25	175-49-23242	管子 Tube	1	
26	07042-20108	螺塞 Screw plug	1	
27	175-49-23281	垫 Pad	1	
28	01602-21236	垫圈 12 Washer 12	4	

### 集中测压管路 PRESSURE MEASUREMENT PIPING

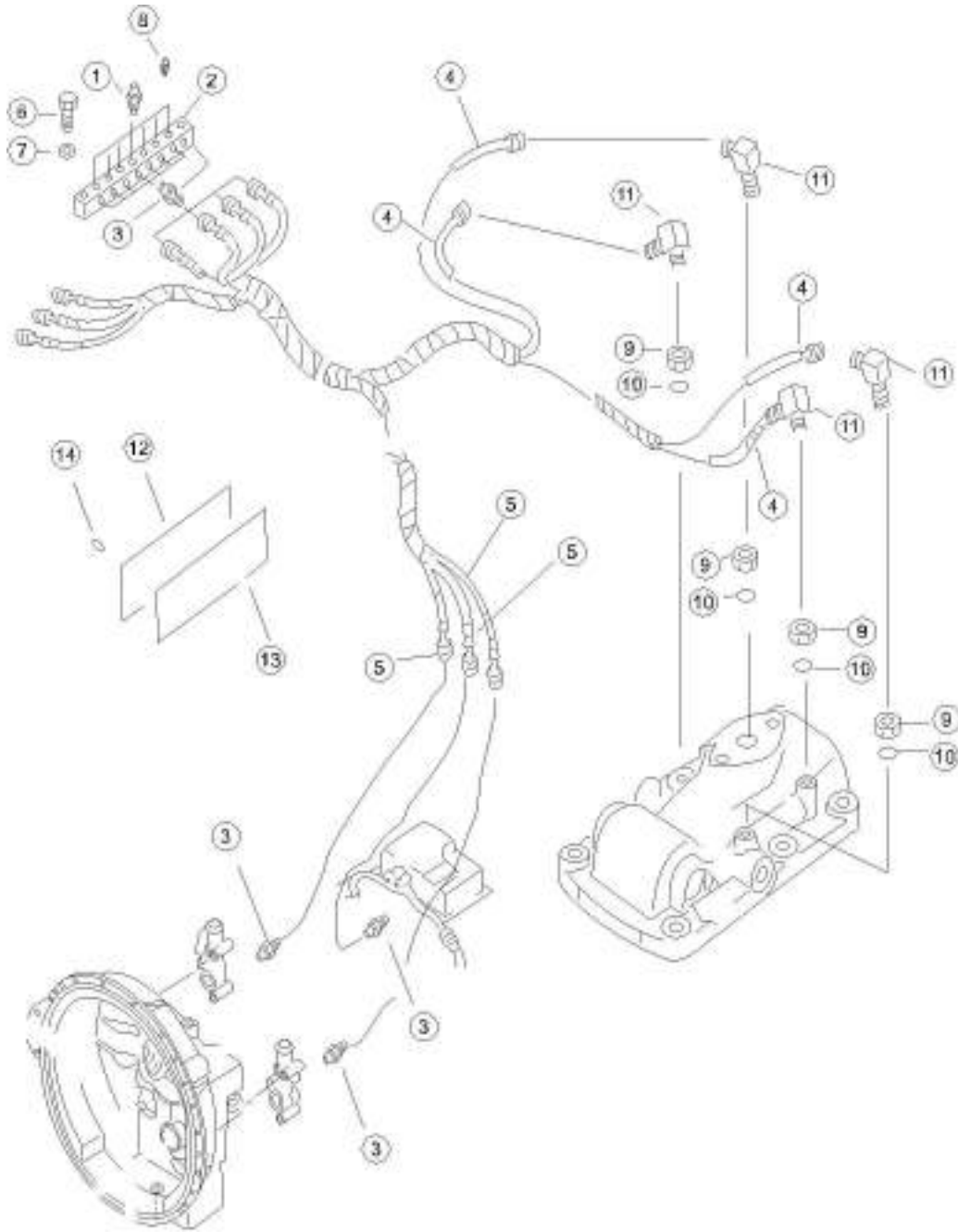

序号 NO.	部件号 PART NO.	零件名称 PART NAME		数量 Q'TY	适用机型 MODEL
1	07042-20108	螺塞	Screw plug	1	
2	16Y-76B-00001	测压座	Pressure measurement seat	1	
3	17Y-74B-00001	接头	Nipple	10	
4	17Y-74B-02000	软管	Hose	4	
5	17Y-74B-01000	软管	Hose	3	
6	01010-51245	螺栓 M12*45	Bolt M12*45	2	
7	01643-31232	垫圈 12	Washer 12	2	
8	14Y-74-36000	测压接头	Pressure measure joint	7	
9	01580-10806	螺母 M8	Nut M8	4	
10	07002-10823	O 形圈	O-ring	4	
11	17Y-74B-00002	接头	Nipple	4	
12	10Y-76B-00002	测压标牌	Label plate	1	
13	16Y-76B-00002	板	Plate	1	
14	04418-02550	标牌铆钉	Rivet	4	

### 平衡梁总成 EQUALIZER BAR ASS'Y

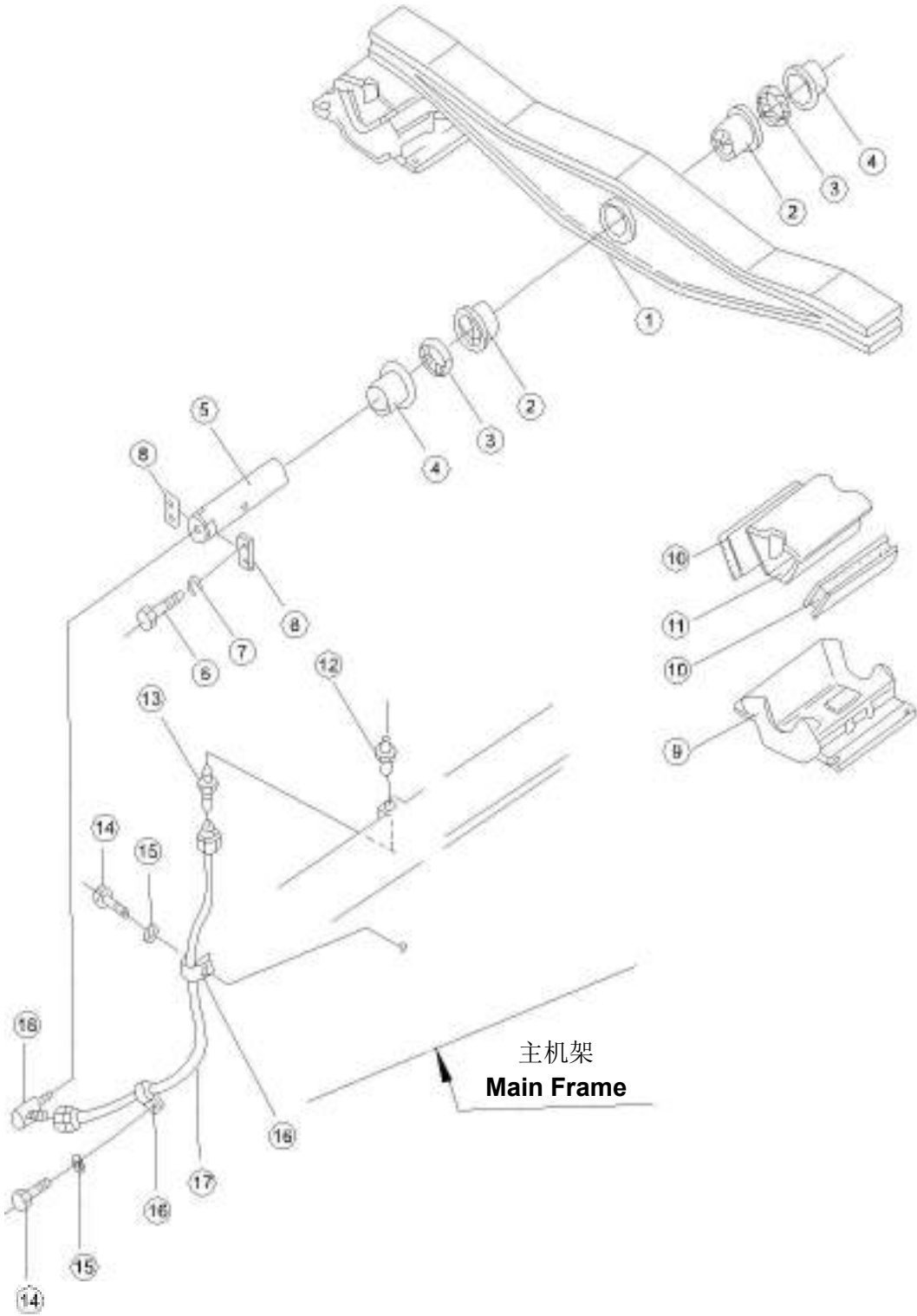

序号 NO.	部件号 PART NO.	零件名称 PART NAME		数量 Q'TY	适用机型 MODEL
1	175-50-31113	平衡梁	Equalizer Bar	1	
2	177-50-11160	衬套	Bushing	2	
3	177-50-11170	防尘圈	Ring, Dust	2	
4	175-50-31160	衬套	Bushing	2	
5	175-50-21134	销	Pin	1	
6	01010-51640	螺栓 M16*40	Bolt M16*40	4	
7	01602-21648	垫圈 16	Washer 16	4	
8	04082-00616	轴端挡板	Retainer	2	
9	175-50-32111	支架	Bracket	2	
10	175-50-12110	缓冲垫	Cushion	4	
11	175-50-22131A	座	Seat	2	
12	07020-01021	油杯 M10*1	Oil cup M10*1	1	
13	07213-80710	接头	Nipple	1	
14	01010-51016	螺栓 M10*16	Bolt M10*16	2	
15	01643-31032	垫圈 10	Washer 10	2	
16	08036-10614	线夹	Wire clip	2	
17	175-50-21190	管	Tube	1	
18	176-43-41350	弯管接头	Elbow	1	

# 终传动箱 FINAL DRIVE CASE

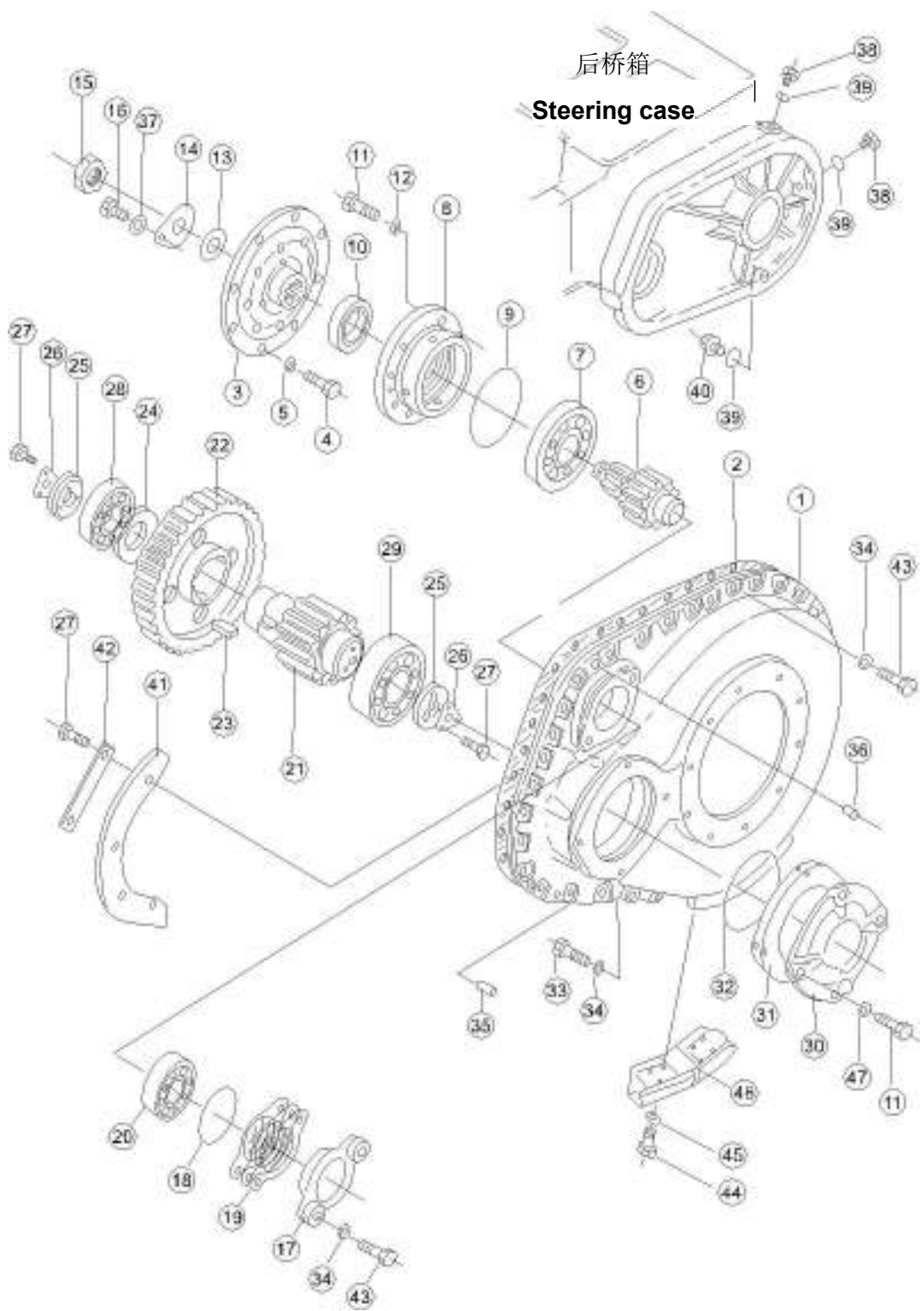

序号 NO.	部件号 PART NO.	零件名称 PART NAME		数量 Q'TY	适用机型 MODEL
1	175-27-31114	左终传动箱	Final drive case (L.H.)	1	
1	175-27-31124	右终传动箱	Final drive case (R.H.)	1	
2	175-27-31132	垫片	Shim	2	
3	175-27-31463	法兰盘	Flange	2	
4	01010-51850	螺栓 M18*50	Bolt M18*50	16	
5	01602-21854	垫圈 18	Washer 18	16	
6	175-27-31495	主动齿轮	Driving gear	2	
7	170-09-13210	轴承	Bearing	2	
8	175-27-31161	轴承座	Bearing support	2	
9	07000-15235	O 形圈	O-ring	2	
10	07013-10120	骨架油封	Oil seal	2	
11	01010-51640	螺栓 M16*40	Bolt M16*40	24	
12	01643-31645	垫圈 16	Washer 16	16	
13	170-27-11232	垫圈	Washer	2	
14	195-27-12620	锁垫	Lock washer	2	
15	170-21-12141	螺帽	Nut	2	
16	01010-51225	螺栓 M12*25	Bolt M12*25	2	
17	175-27-31170	盖	Cover	2	
18	07000-15150	O 形圈	O-ring	2	
19.10	175-27-31180	垫片	Shim	8	
19.20	175-27-31190	垫片	Shim	4	
19.30	175-27-31210	垫片	Shim	2	
19	175-27-00051	垫片总成	Shim ass'y	2	
20	170-09-13220	轴承	Bearing	2	
21	175-27-31233	小齿轮	Pinion	2	
22	175-27-31255	齿轮	Gear	2	
23	175-27-31260	键	Key	6	
24	175-27-31270	垫圈	Washer	2	
25	175-27-31282	夹圈	Clamping ring	4	
26	175-27-32470	锁片	Locking plate	4	
27	01010-51230	螺栓 M12*30	Bolt M12*30	20	
28	170-09-13230	轴承	Bearing	2	
29	170-09-13240	轴承	Bearing	2	
30	175-27-31291	盖	Cover	2	

# 终传动箱 FINAL DRIVE CASE

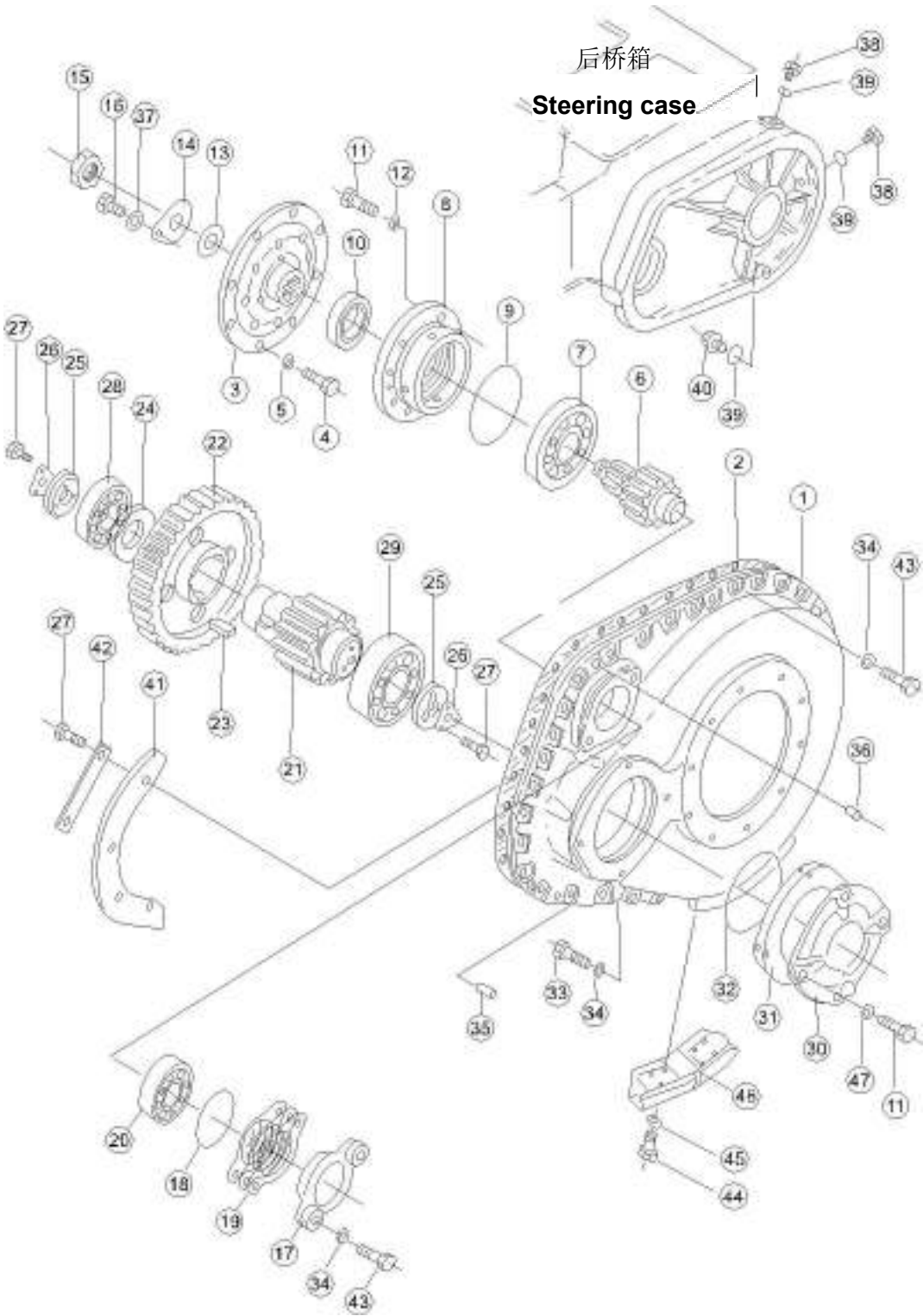

序号 NO.	部件号 PART NO.	零件名称 PART NAME	数量 Q'TY	适用机型 MODEL
31.10	175-27-31310	垫片 Shim	1	
31.20	175-27-31320	垫片 Shim	2	
31.30	175-27-31330	垫片 Shim	4	
31	175-27-00061		2	
32	07000-15260	O 形圈 O-ring	2	
33	01010-52055	螺栓 M20*55 Bolt M20*55	72	
34	01602-22060	弹簧垫圈 20 Spring washer 20	76	
35	04020-01842	圆柱销 Cylindrical pin	4	
36	07049-12018	防尘塞 Plug, Dust	4	
37	01602-21236	垫圈 12 Washer 12	2	
38	07040-13618	螺塞 Screw plug	4	
39	07002-13634	O 形圈 O-ring	6	
40	07044-13620	螺塞 Screw plug	2	
41	175-27-31530	板 Plate	2	
42	175-27-31540	锁片 Locking plate	4	
43	01010-52050	螺栓 M20*50 Bolt M20*50	4	
44	01010-52455	螺栓 M24*55 Bolt M24*55	16	
45	01602-22472	垫圈 24 Washer 24	16	
46	175-27-32611	左护板 Guard plate (L.H.)	1	
46	175-27-32641	右护板 Guard plate (R.H.)	1	
47	01602-21648	垫圈 16 Washer 16	8	

### 终传动齿轮轴与链轮 FINAL DRIVE GEAR SHAFT AND SPROCKET

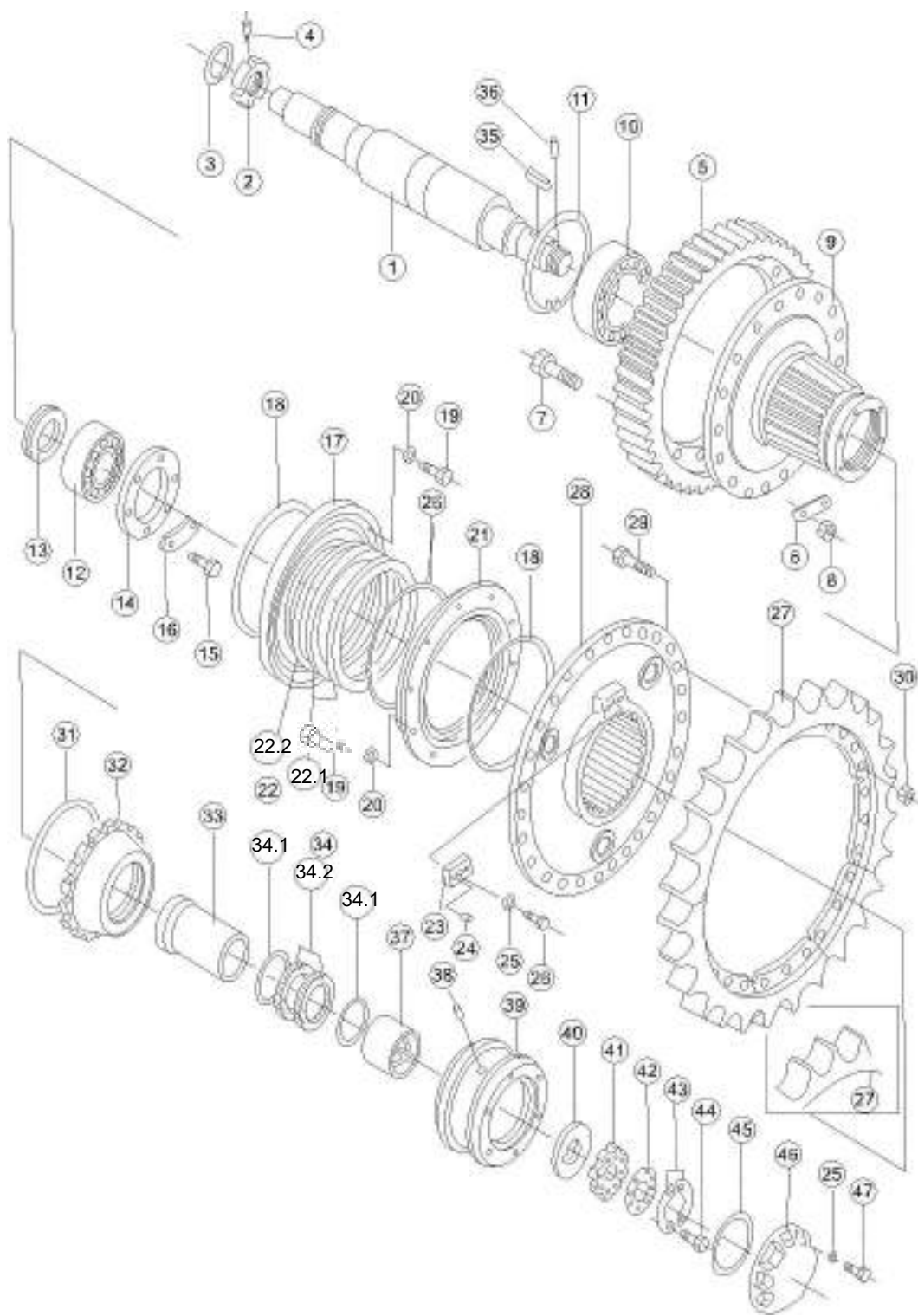

序号 NO.	部件号 PART NO.	零件名称 PART NAME	数量 Q'TY	适用机型 MODEL
1	175-27-31343	半轴 Half shaft	2	
2	170-27-12472	螺母 Nut	2	
3	170-27-12480	环 Ring	2	
4	170-27-12491	销 Pin	2	
5	175-27-31362	齿圈 Gear ring	2	
6	175-27-31370	锁片 Locking plate	18	
7	175-27-12181	螺栓 Bolt	36	
8	01582-02419	螺母 M24*1.5 Nut M24*1.5	36	
9	175-27-31384	齿轮毂 Gear hub	2	
10	GB288-23134CC3	调心滚子轴承 Spherical Roller Bearing	2	
11	04071-00280	挡圈 Retainer ring	2	
12	170-09-13250	双列圆柱轴承 Double row cylindrical bearing	2	
13	175-27-22131	垫环 Loop	2	
14	175-27-22140	法兰盘 Flange	2	
15	01010-51440	螺栓 M14*40 Bolt M14*40	12	
16	170-27-12210	锁垫 Lock washer	6	
17	154-27-12152	盖 Cover	2	
18	07000-15410	O 形圈 O-ring	4	
19	01010-51230	螺栓 M12*30 Bolt M12*30	40	
20	01602-21236	垫圈 12 Washer 12	40	
21	154-27-12162	盖 Cover	2	
22	170-27-00021	浮动油封总成 Floating oil seal ass'y	2	
22.10	170-27-12513	浮动油封 Floating oil seal	2	
22.20	170-27-12520	O 形圈 O-ring	2	
23	175-27-31480	锁挡 Block	2	
24	170-27-12250	定位销 Pin, Dowel	4	
25	01602-21648	垫圈 16 Washer 16	14	
26	01252-71635	螺钉 M16*35 Screw M16*35	2	
27	175-27-22325	齿块 Tooth block	18	
27	175-27-22325A	齿块 Tooth block	18	
28	175-27-31394	链轮毂 Sprocket hub	2	
29	178-27-11150	螺栓 Bolt	54	
30	01803-12430	螺母 M24 Nut M24	54	
31	07000-15315	O 形圈 O-ring	2	
32	175-27-22150	螺母 Nut	2	
33	175-27-31411	隔套 Spacer	2	

### 终传动齿轮轴与链轮 FINAL DRIVE GEAR SHAFT AND SPROCKET

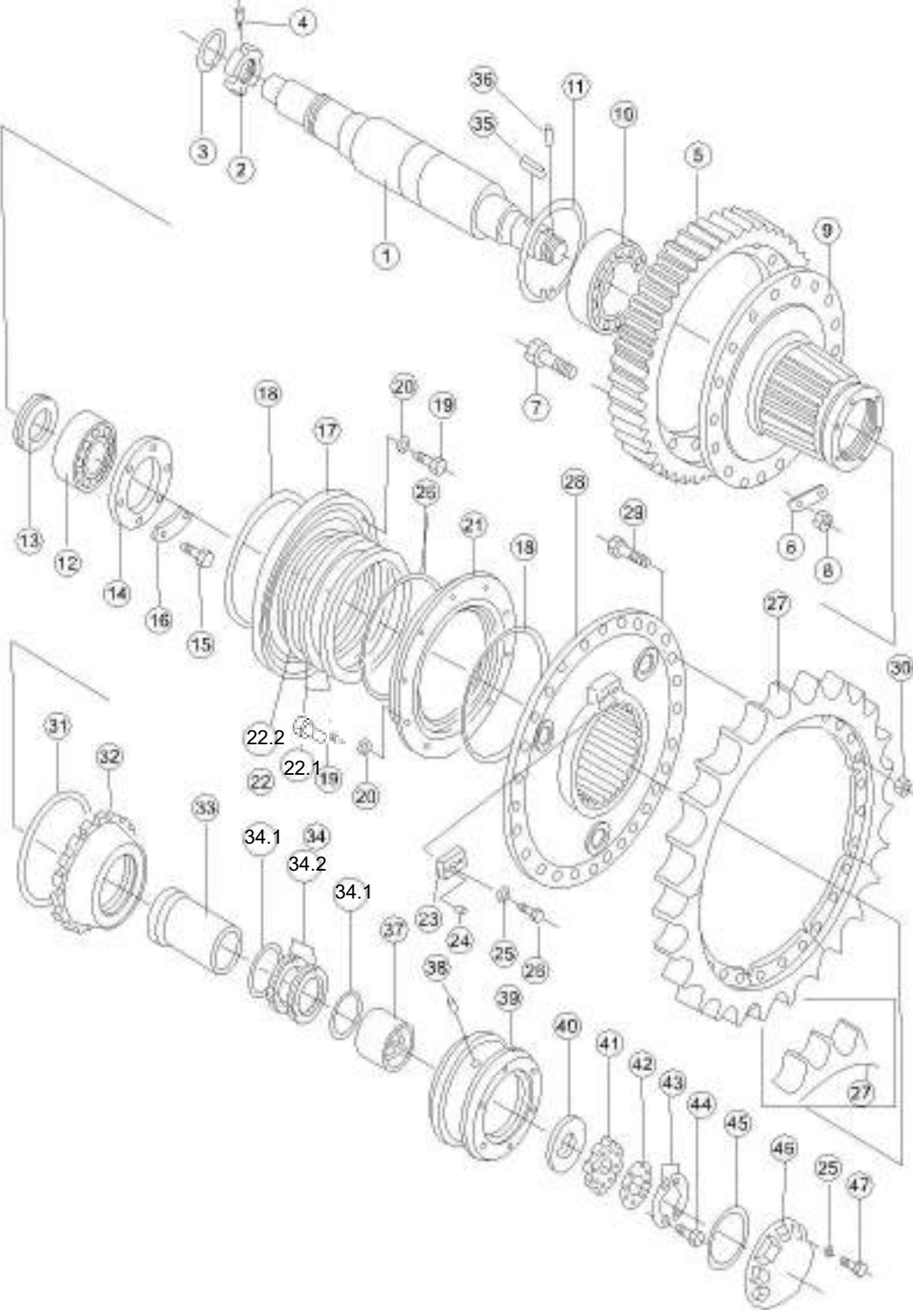

序号 NO.	部件号 PART NO.	零件名称 PART NAME		数量 Q'TY	适用机型 MODEL
34.10	175-27-32711	浮动油封	Floating oil seal	2	
34	175-27-00120	浮动油封总成	Floating oil seal ass'y	2	
34.20	100-27-11330	O 形圈	O-ring	2	
35	04000-01580	平键	Flat key	2	
36	175-27-32510	定位销	Pin, Dowel	2	
37	175-27-31441	轴套	Sleeve	2	
38	04020-01638	圆柱销	Cylindrical pin	2	
39	175-27-31510	支座	Seat	2	
40	175-27-22255	垫圈	Washer	2	
41	175-27-22272	螺母	Nut	2	
42	175-27-31550	锁片	Locking plate	2	
43	175-27-31560	锁片	Locking plate	2	
44	01010-51225	螺栓 M12*25	Bolt M12*25	4	
45	07000-15185	O 形圈	O-ring	2	
46	175-27-22242	盖	Cover	2	
47	01010-51645	螺栓 M16*45	Bolt M16*45	12	

A series of horizontal dashed lines for writing notes.

行走系统

**TRACK SYSTEM**

# 台车架 TRACK FRAME ASS'Y

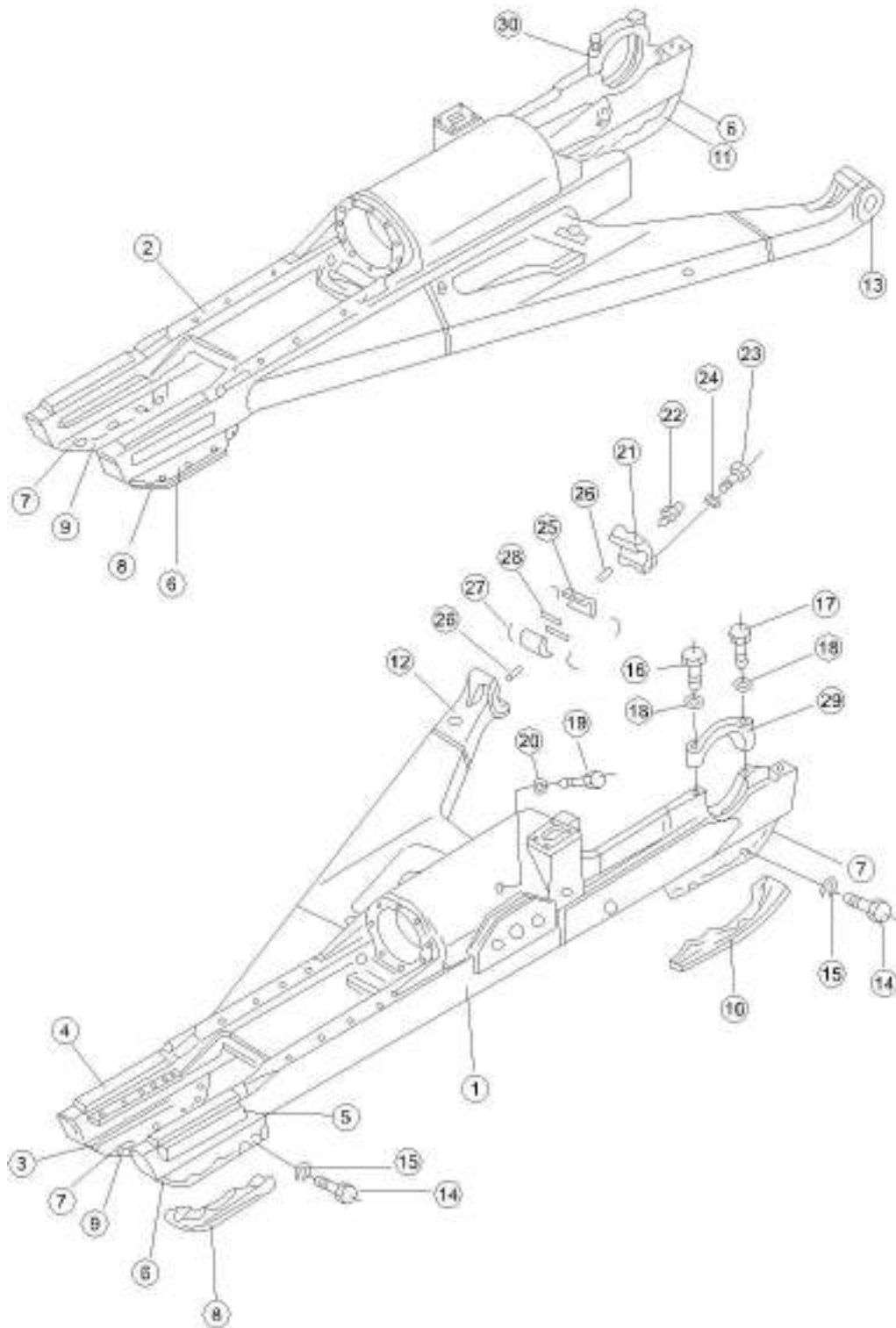

序号 NO.	部件号 PART NO.	零件名称 PART NAME	数量 Q'TY	适用机型 MODEL
0	175-30-30004	台车部件 Track frame part	1	
1	175-30-31115	左台车架 Track frame (L.H.)	1	
2	175-30-31218	右台车架 Track frame (R.H.)	1	
3	175-30-11272	板 Plate	4	
4	175-30-21333	板 Plate	4	
5	175-30-21342	板 Plate	4	
6	175-30-21353	防护装置 Guard	3	
7	175-30-21363	防护装置 Guard	3	
8	178-30-12161A	护板 Guard plate	2	
9	178-30-12171A	护板 Guard plate	2	
10	178-30-12140	左板 Plate (L.H.)	1	
11	178-30-12150	右板 Plate (R.H.)	1	
12	175-30-31142	左支撑前段 Support (L.H.)	1	
13	175-30-31242	右支撑前段 Support (R.H.)	1	
14	01010-52045	螺栓 M20*45 Bolt M20*45	24	
15	01643-32060	垫圈 20 Washer 20	24	
16	01011-53040	螺栓 M30*3*140 Bolt M30*3*140	2	
17	01011-53090	螺栓 M30*3*190 Bolt M30*3*190	2	
18	01601-23075	垫圈 30 Washer 30	4	
19	07040-13016	螺塞 Screw plug	2	
20	07002-13034	O 形圈 O-ring	2	
21	154-30-11612	轴承盖 Bearing Cover	2	
22	07020-01021	油杯 M10*1 Oil cup M10*1	2	
23	01011-52400	螺栓 M24*100 Bolt M24*100	8	
24	01602-22472	垫圈 24 Washer 24	8	
25	154-30-11810	轴瓦 Bushing	4	
26	04020-01024	圆柱销 Cylindrical pin	4	
27	154-30-11821	密封圈 Seal ring	8	
28	154-30-11831	密封垫 Gasket	4	
29	175-30-31530	轴承盖 Bearing Cover	1	
30	175-30-31540	轴承盖 Bearing Cover	1	

# 涨紧装置 TENSION DEVICE

限制器左面  
Stopper L.H.

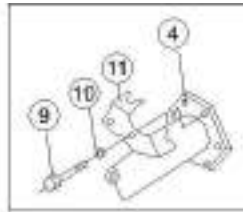

限制器右面  
Stopper R.H.

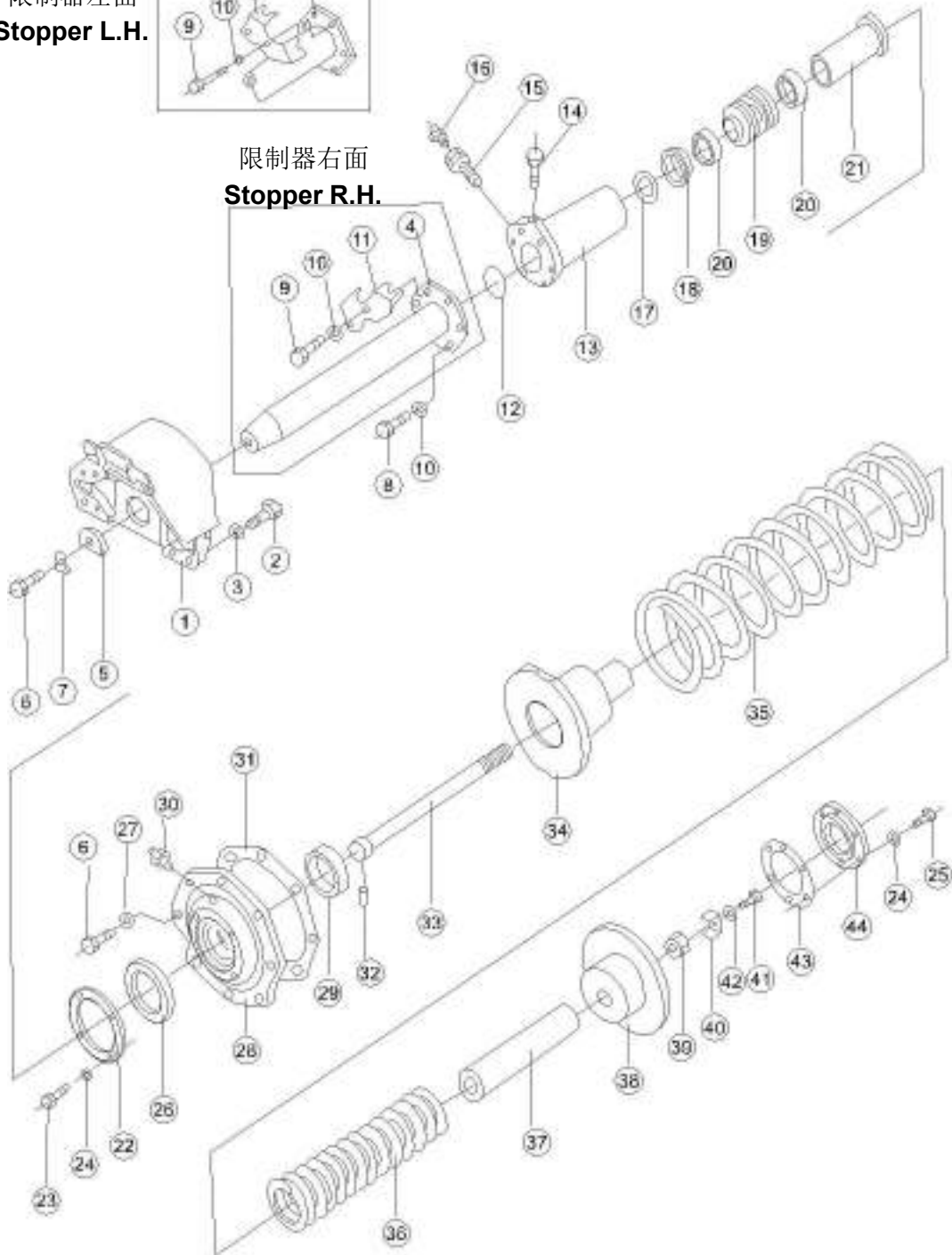
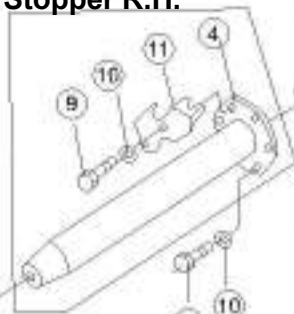

序号 NO.	部件号 PART NO.	零件名称 PART NAME	数量 Q'TY	适用机型 MODEL
1	176-30-44110	座罩 Seat cover	2	
2	01010-52095	螺栓 M20*95 Bolt M20*95	16	
3	01602-22060	弹簧垫圈 20 Spring washer 20	16	
4	175-30-34210	轴 Shaft	2	
5	195-30-14151	垫圈 Washer	2	
6	01010-52460	螺栓 M24*60 Bolt M24*60	18	
7	195-30-14160	止动垫 Spacer	2	
8	01010-51650	螺栓 M16*50 Bolt M16*50	8	
9	01010-51655	螺栓 M16*55 Bolt M16*55	4	
10	01602-21648	垫圈 16 Washer 16	12	
11	175-30-34161	罩 Cover	2	
12	07000-15090	O 形圈 O-ring	2	
13	175-30-24222	油缸 Oil cylinder	2	
14	198-30-14420	油塞 Oil plug	2	
15	195-30-13191	注油器 Grease fitting	2	
16	07020-01021	油杯 M10*1 Oil cup M10*1	2	
17	04064-07525	挡圈 Retainer ring	2	
18	175-30-24242	密封环 Sealing ring	2	
19	170-30-14211	活塞 Piston	2	
20	170-30-14230	环 Ring	4	
21	175-30-24361	销子 Pin	2	
22	175-30-24270	垫 Pad	2	
23	01010-51225	螺栓 M12*25 Bolt M12*25	8	
24	01602-21236	垫圈 12 Washer 12	20	
25	01010-51235	螺栓 M12*35 Bolt M12*35	12	
26	07019-00130	防尘油封 Seal, Dust	2	
27	01602-22472	垫圈 24 Washer 24	16	
28	175-30-34252	盖 Cover	2	
29	170-30-14221	衬套 Bushing	2	
30	07021-01060	油杯 60° M10*1 Oil cup 60° M10*1	2	
31	175-30-34260	垫圈 Washer	2	
32	04020-01024	圆柱销 Cylindrical pin	2	
33	175-30-34312	螺栓 Bolt	2	
34	175-30-34140	导向座 Seat, Guide	2	
35	175-30-34180	弹簧 Spring	2	
36	175-30-34190	弹簧 Spring	2	
37	175-30-34320	套筒 Sleeve	2	

# 涨紧装置 TENSION DEVICE

限制器左面  
Stopper L.H.

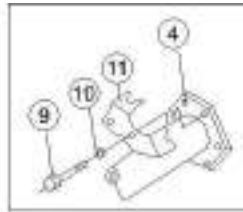

限制器右面  
Stopper R.H.

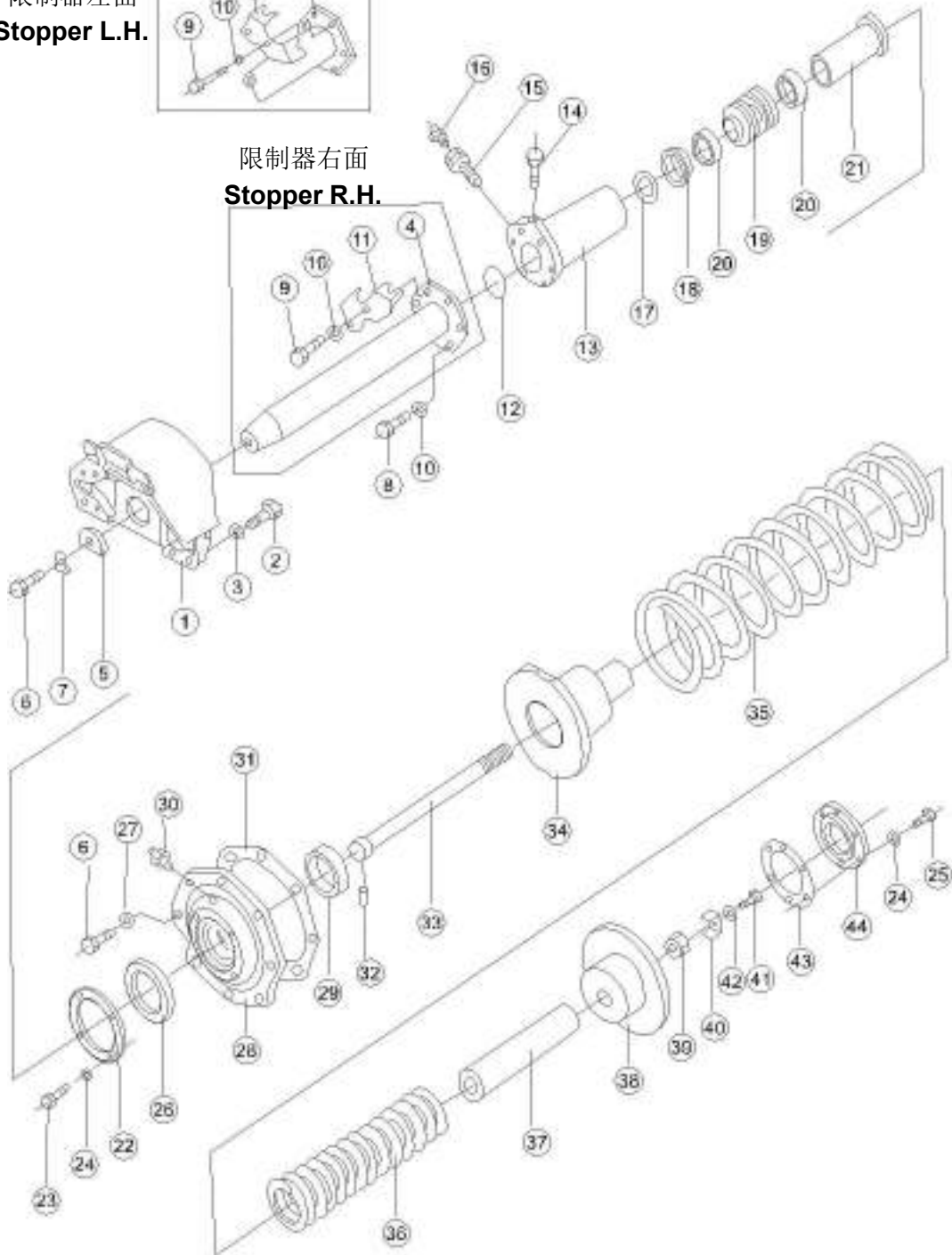
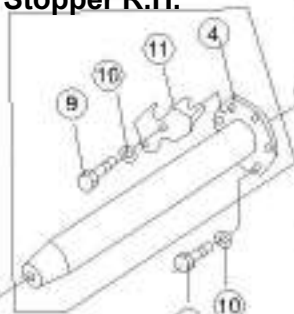

序号 NO.	部件号 PART NO.	零件名称 PART NAME		数量 Q'TY	适用机型 MODEL
38	175-30-34150	导向座	Seat, Guide	2	
39	170-30-14351	螺母	Nut	2	
40	170-30-34290	止动垫	Spacer	2	
41	01010-51020	螺栓 M10*20	Bolt M10*20	2	
42	01602-21030	垫圈 10	Washer 10	2	
43	170-30-14341	垫片	Shim	2	
44	175-30-34331	盖	Cover	2	

# 台车架盖 TRACK FRAME COVER

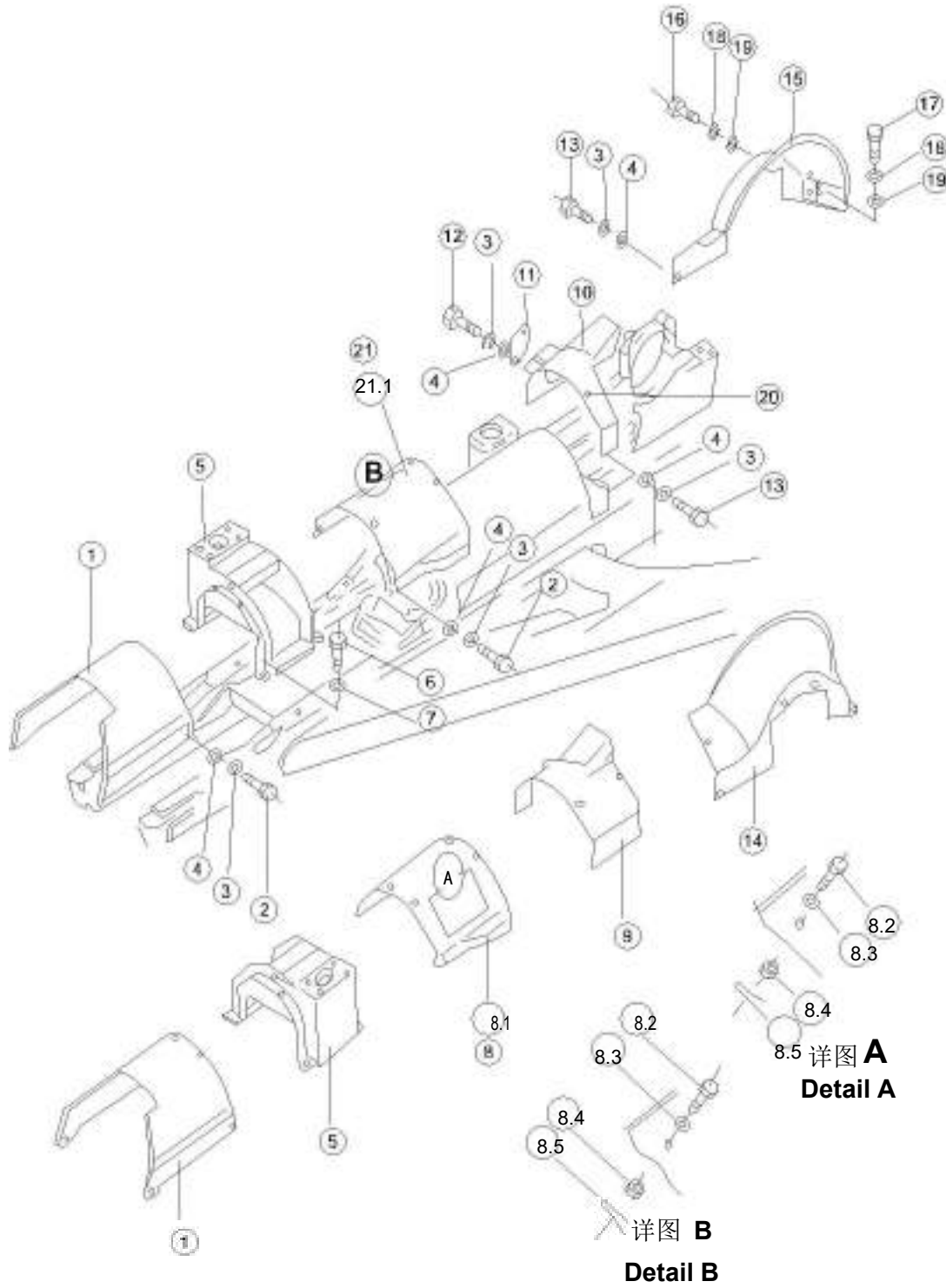

序号 NO.	部件号 PART NO.	零件名称 PART NAME	数量 Q'TY	适用机型 MODEL
1	175-30-37154	罩 Cover	2	
2	01010-51430	螺栓 M14*30 Bolt M14*30	28	
3	01602-21442	垫圈 14 Washer 14	40	
4	01643-31445	垫圈 14 Washer 14	40	
5	175-30-37113	支架 Bracket	2	
6	01010-52080	螺栓 M20*80 Bolt M20*80	8	
7	01602-22060	弹簧垫圈 20 Spring washer 20	8	
8.30	01642-21216	垫圈 12 Washer 12	2	
8.40	01590-31215	螺母 M12 Nut M12	2	
8	175-30-37103	罩壳组件 Casing ass'y	1	
8.10	175-30-37220	左罩壳 Casing (L.H.)	1	
8.20	195-09-18140	螺栓 Bolt	2	
9	175-30-37170	左罩 Cover (L.H.)	1	
8.50	04050-13026	开口销 Cotter pin	2	
10	175-30-37186	右罩 Cover (R.H.)	1	
11	175-30-37212	板 Plate	1	
12	01010-51445	螺栓 M14*45 Bolt M14*45	2	
13	01010-51440	螺栓 M14*40 Bolt M14*40	10	
14	175-30-27143A	驱动轮罩 (左) Hood (L.H.)	1	
15	175-30-27133A	驱动轮罩 (右) Hood (R.H.)	1	
16	01010-51635	螺栓 M16*35 Bolt M16*35	4	
17	01010-51650	螺栓 M16*50 Bolt M16*50	4	
18	01602-21648	垫圈 16 Washer 16	8	
19	01643-31645	垫圈 16 Washer 16	8	
20	07049-01418	防尘塞 Plug, Dust	2	
21	175-30-37200	罩壳组件 Casing ass'y	1	
21.10	175-30-37230	右罩壳 Casing (R.H.)	1	

# 支重轮护板 GUARD PLATE

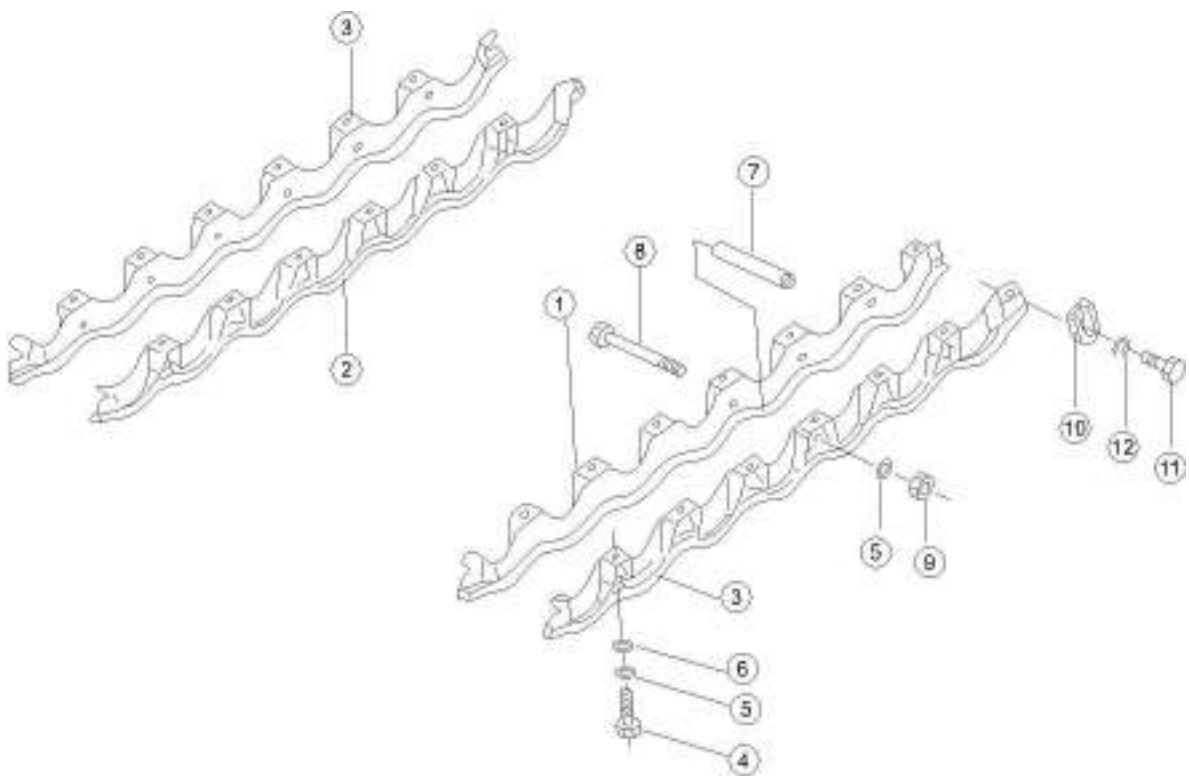

序号 NO.	部件号 PART NO.	零件名称 PART NAME		数量 Q'TY	适用机型 MODEL
1	175-30-32175	防护装置	Guard	1	
2	175-30-32185	防护装置	Guard	1	
3	175-30-32195	防护装置	Guard	2	
4	01010-52490	螺栓 M24*90	Bolt M24*90	24	
5	01602-22472	垫圈 24	Washer 24	36	
6	01643-32460	垫圈 24	Washer 24	24	
7	175-30-32151	衬套	Bushing	12	
8	175-30-32162	螺栓	Bolt	12	
9	01580-12419	螺母 M24	Nut M24	12	
10	170-30-12162	挡板	Plate	6	
11	01010-52050	螺栓 M20*50	Bolt M20*50	12	
12	01602-22060	弹簧垫圈 20	Spring washer 20	12	

# 引导轮总成 FRONT IDLER ASS'Y

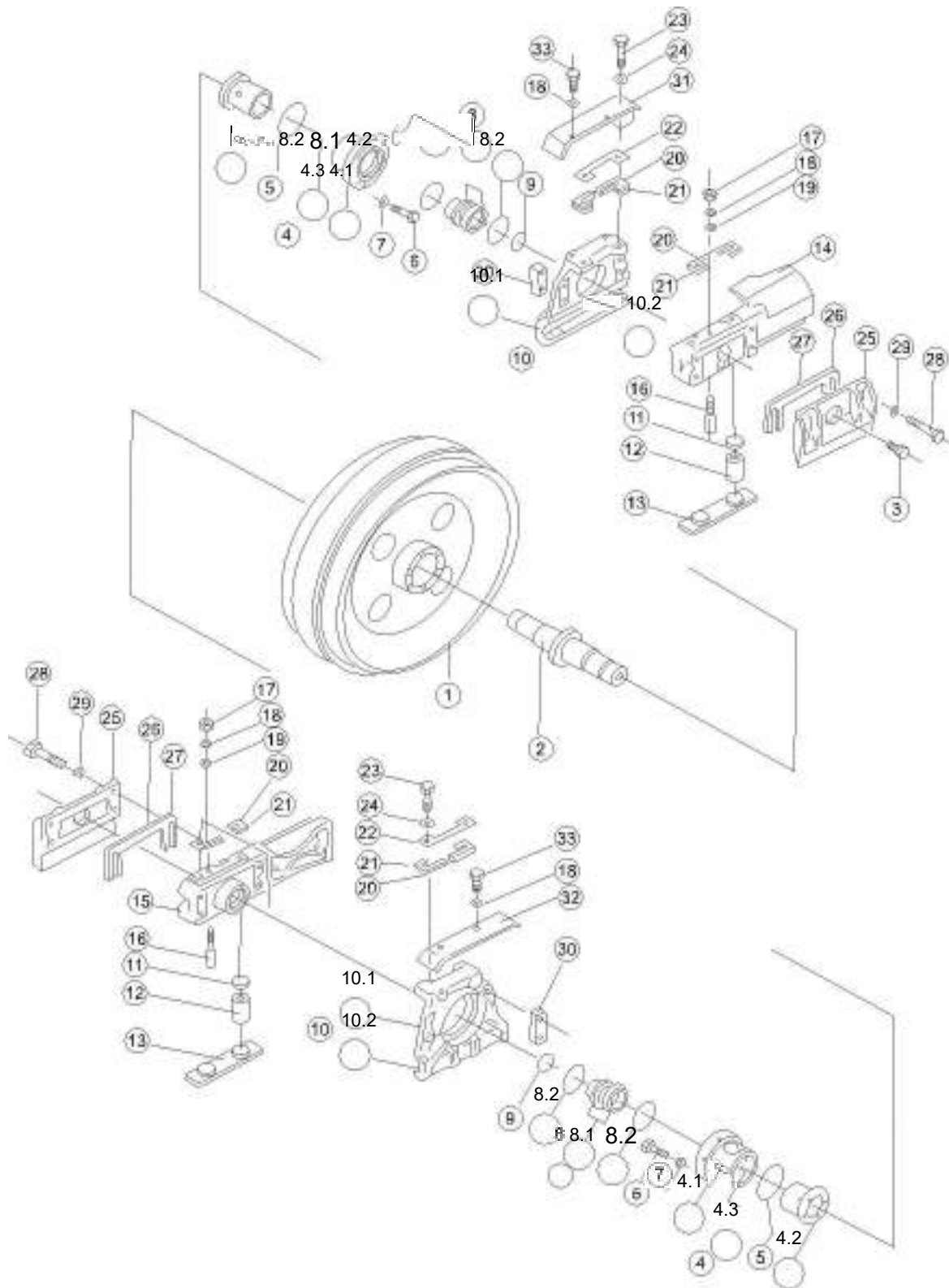

序号 NO.	部件号 PART NO.	零件名称 PART NAME	数量 Q'TY	适用机型 MODEL
1	175-30-23114	引导轮 Idler	2	
2	175-30-23121	轴 Shaft	2	
3	07052-31624	螺塞 Screw plug	2	
4.30	170-30-91130	销 Pin	8	
4	175-30-36108	套筒 Sleeve	4	
4.10	175-30-36168	轴衬 Bushing	4	
4.20	175-30-36172A	套筒 Sleeve	4	
5	07000-12130	O 形圈 O-ring	4	
6	01010-51235	螺栓 M12*35 Bolt M12*35	24	
7	01602-21236	垫圈 12 Washer 12	24	
8.10	175-30-36273	浮封 Float seal	8	
8	175-30-00701	浮动油封总成 Floating oil seal ass'y	4	
8.20	175-30-16215	O 形圈 O-ring	8	
9	07000-13068	O 形圈 O-ring	4	
10	175-30-33272	导轮支架 Idler support	4	
10.10	175-30-33282	导轮支架 Idler support	4	
10.20	170-30-13343	板 Plate	4	
11	195-30-17960	垫板 Plate	8	
12	155-30-13230	橡胶弹簧 Rubber spring	8	
13	175-30-24131	导板铆合件 Riveting ass'y	4	
14	176-30-43111	支承 Fulcrum bearing	2	
15	176-30-43121	支承 Support	2	
16	175-30-23172	螺栓 Bolt	4	
17	175-30-23180	螺母 Nut	4	
18	01602-21648	垫圈 16 Washer 16	12	
19	01640-21626	垫圈 16 Washer 16	4	
20	175-30-33440	垫片 Shim	48	
21	175-30-33450	垫片 Shim	24	
22	175-30-33460	板 Plate	4	
23	175-30-33492	螺栓 Bolt	8	
24	01602-22060	弹簧垫圈 20 Spring washer 20	8	
25	175-30-33214	侧板 Side plate	4	
26	175-30-33420	垫片 Shim	4	
27	170-30-13234	垫片 Shim	36	
28	01011-52260	螺栓 M22*160 Bolt M22*160	16	
29	01602-22268	垫圈 22 Washer 22	16	
30	175-30-33430	垫片 Shim	8	
31	175-30-33471	罩 Cover	2	
32	175-30-33481	罩 Cover	2	
33	01010-51635	螺栓 M16*35 Bolt M16*35	8	

# 支重轮总成 TRACK ROLLER ASS'Y

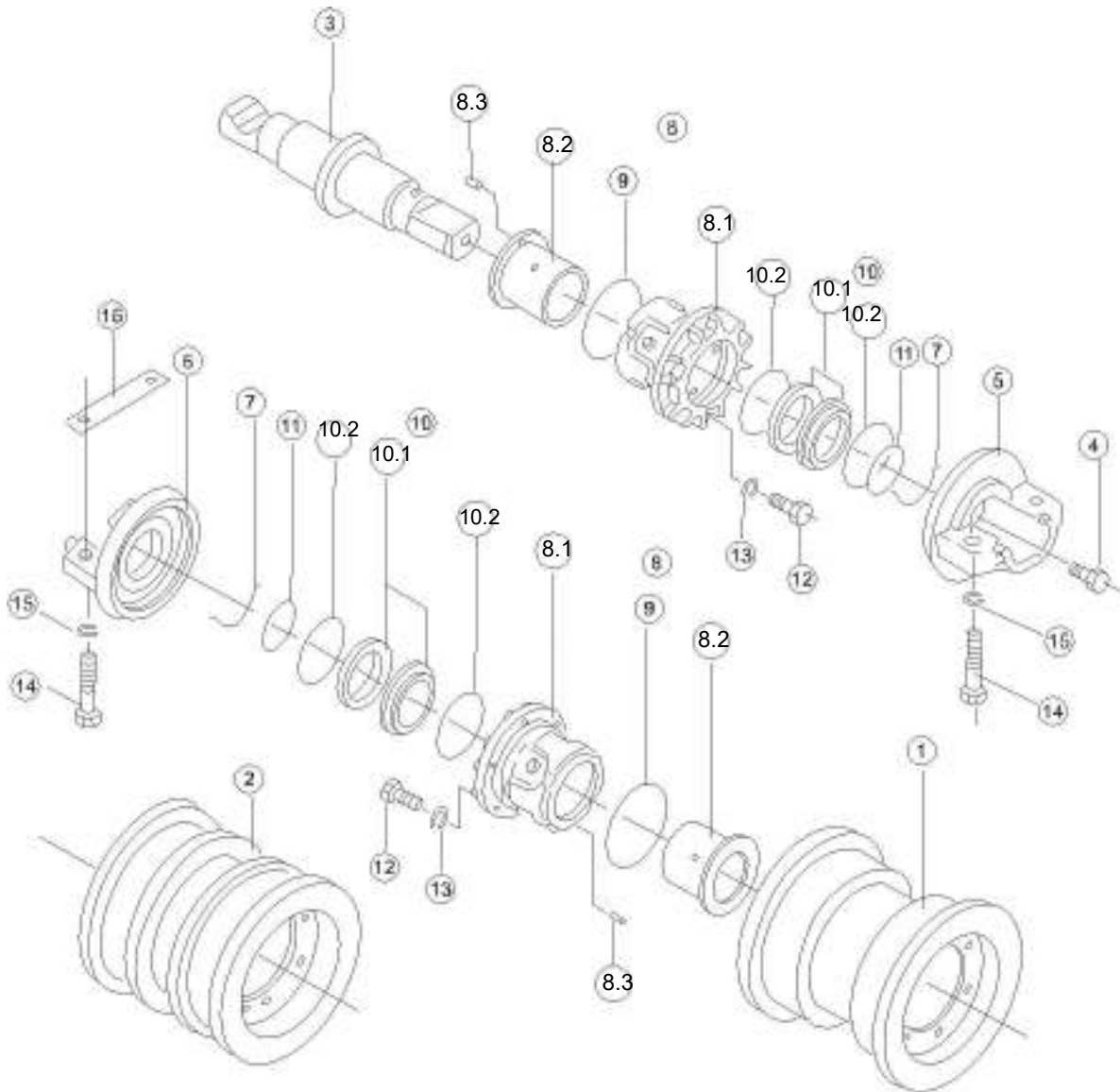

序号 NO.	部件号 PART NO.	零件名称 PART NAME	数量 Q'TY	适用机型 MODEL
0	175-30-00486	单边支重轮总成	4	
0	175-30-00496	双边支重轮总成	10	
1	178-30-16113	单边支重轮	4	
2	178-30-16123	双边支重轮	10	
3	175-30-36130	支重轮轴	14	
4	07052-31624	螺塞	14	
5	175-30-36210	支重轮盖	14	
6	175-30-36220	支重轮盖	14	
7	175-30-26230	挡环	28	
8.10	175-30-36168	轴衬	28	
8.20	175-30-36172A	套筒	28	
8.30	170-30-91130	销	56	
8	175-30-36108	套筒	28	
9	07000-12130	O 形圈	28	
10	175-30-00701	浮动油封总成	28	
10.20	175-30-16215	O 形圈	56	
10.10	175-30-36273	浮封	56	
11	07000-13068	O 形圈	28	
12	01010-51235	螺栓 M12*35	168	
13	01602-21236	垫圈 12	168	
14	01011-82415	螺栓 M24*115	56	
15	01602-22472	垫圈 24	56	
16	175-30-26241	板	14	

# 托轮总成 CARRIER ROLLER ASS'Y

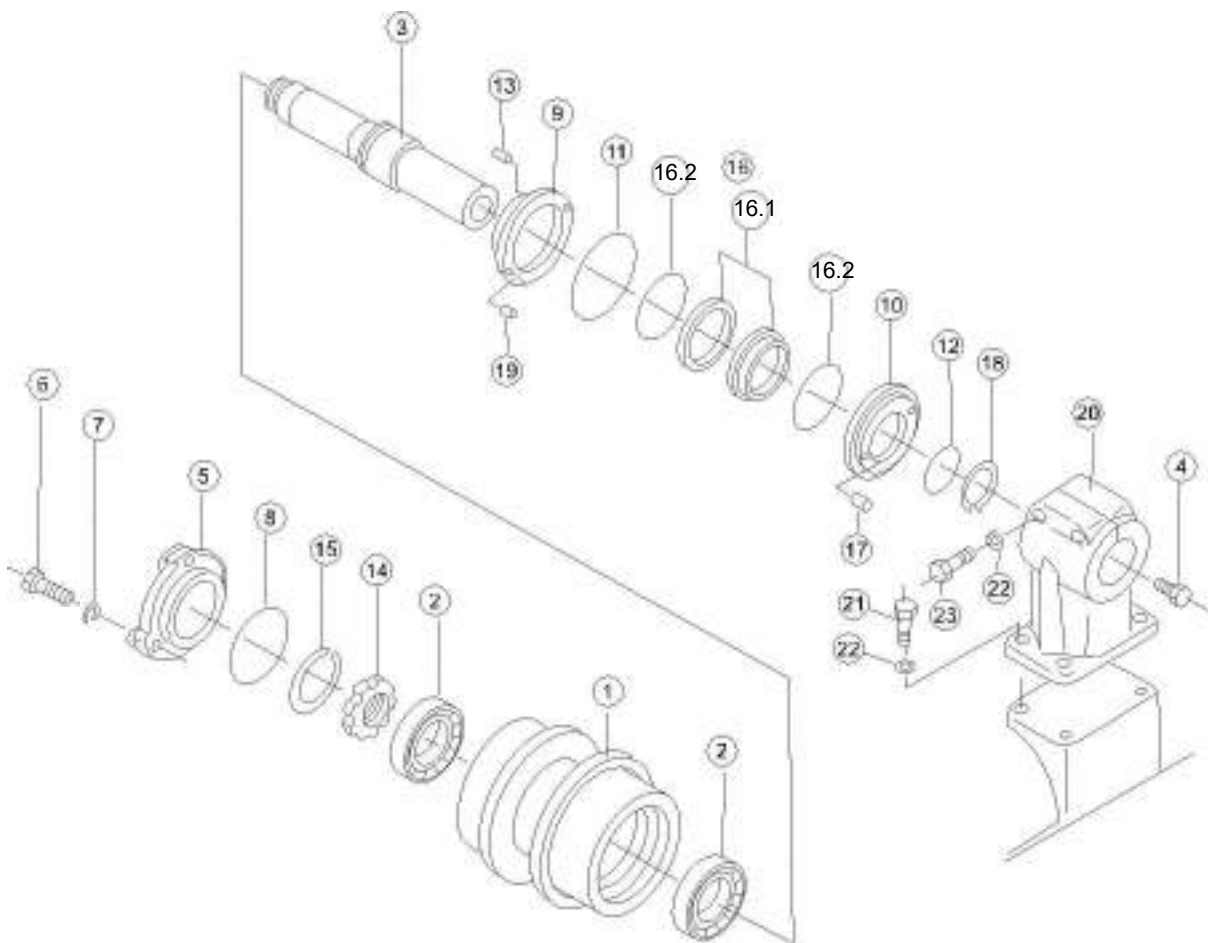

序号 NO.	部件号 PART NO.	零件名称 PART NAME		数量 Q'TY	适用机型 MODEL
1	175-30-45110A	托轮	Carrier roller	4	
2	GB297-30212	圆锥滚子轴承	Tapered Roller Bearing	8	
3	175-30-25130	托轮轴	Carrier roller shaft	4	
4	07052-31624	螺塞	Screw plug	4	
5	175-30-45130	盖	Cover	4	
6	01010-51440	螺栓 M14*40	Bolt M14*40	12	
7	01602-21442	垫圈 14	Washer 14	12	
8	07000-15105	O 形圈	O-ring	4	
9	175-30-35160	密封导座	Guide seat	4	
10	175-30-35170	密封导座	Guide seat	4	
11	07000-12130	O 形圈	O-ring	4	
12	07000-13065	O 形圈	O-ring	4	
13	04020-00616	圆柱销	Cylindrical pin	8	
14	170-30-15190	螺母	Nut	4	
15	170-30-15210	环	Ring	4	
16	175-30-00701	浮动油封总成	Floating oil seal ass'y	4	
16.20	175-30-16215	O 形圈	O-ring	8	
16.10	175-30-36273	浮封	Float seal	8	
17	175-30-35180	圆销	Pin	8	
18	04064-07025	挡圈	Retainer ring	4	
19	07049-00811	防尘塞	Plug, Dust	8	
20	175-30-25184	托轮支架	Carrier roller support	4	
21	01010-52065	螺栓 M20*65	Bolt M20*65	16	
22	01602-22060	弹簧垫圈 20	Spring washer 20	24	
23	01010-52090	螺栓 M20*90	Bolt M20*90	8	

# 履带总成 TRACK ASS'Y

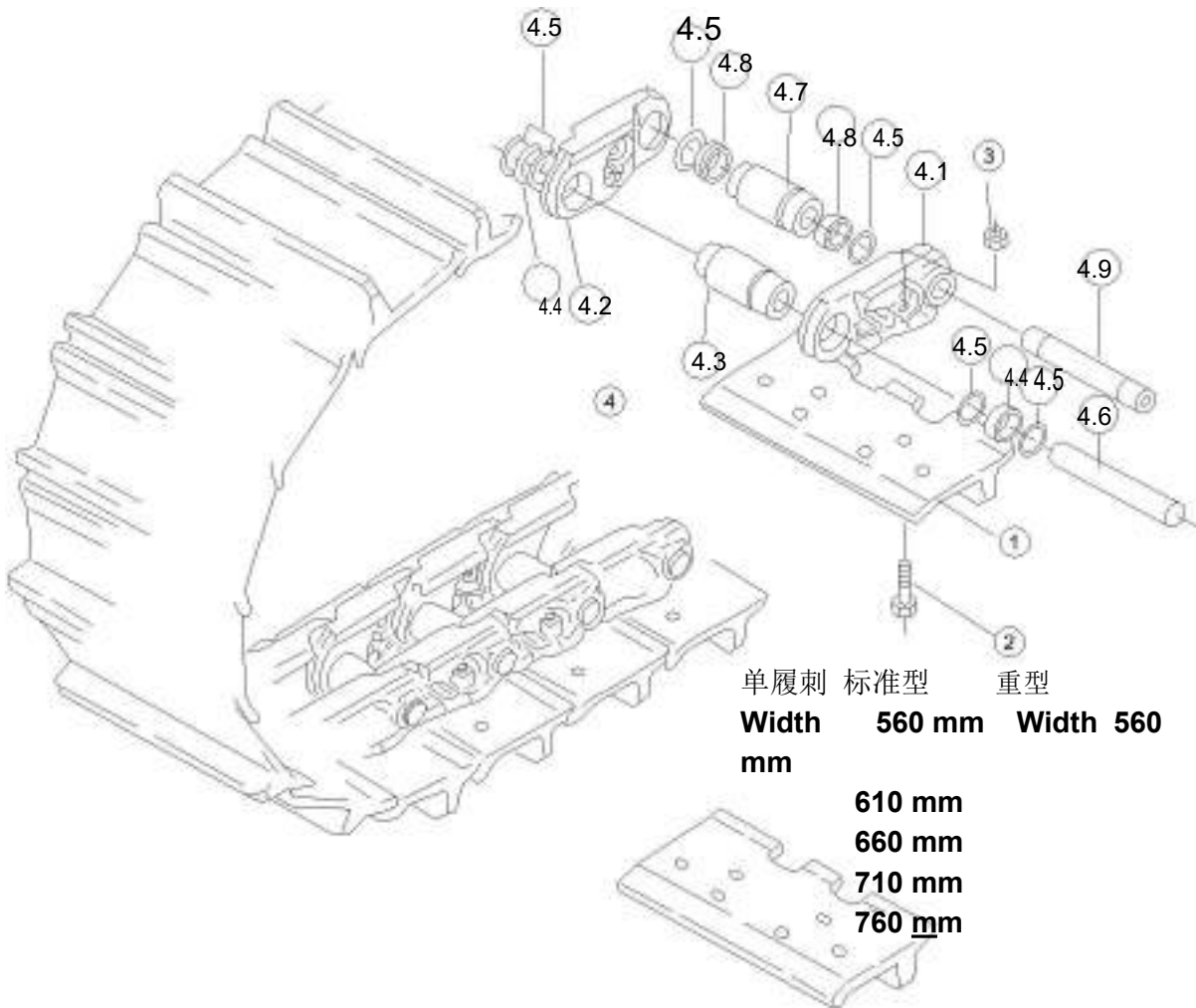

序号 NO.	部件号 PART NO.	零件名称 PART NAME	数量 Q'TY	适用机型 MODEL
0	8228-MC-411561	履带总成 Track ass'y	2	
0	8228-MC-411562	履带总成 Track ass'y	2	
1	8228-MA-001561	履带板 Track shoe	82	
1	8228-MA-001562	履带板 Track shoe	82	
2	8228-MA-00062	螺栓 Bolt	328	
3	8228-MA-00061	螺母 Nut	328	
4.40	8228-MA-00052	密封垫 Gasket	160	
4.30	8228-MA-00031	销套 Bushing	80	
4.10	8228-MC-00011	左链轨节 Track link (L.H.)	82	
4.20	8228-MC-00021	右链轨节 Track link (R.H.)	82	
4.70	8228-MA-00032	主销套 Main pin's sleeve	2	
4.60	8228-MA-00041	销轴 Pin shaft	80	
4.90	8228-MA-00042	主销轴 Pin shaft, Master	2	
4.50	8228-MA-00051	碟形密封圈 Ring, Dish	324	
4.80	8228-MA-00053	主密封垫 Gasket, Master	4	

A page of horizontal dashed lines for writing notes. The lines are evenly spaced and run across the width of the page, providing a guide for text entry.

护罩

**GUARD**

# 散热器防护装置 RADIATOR GUARD

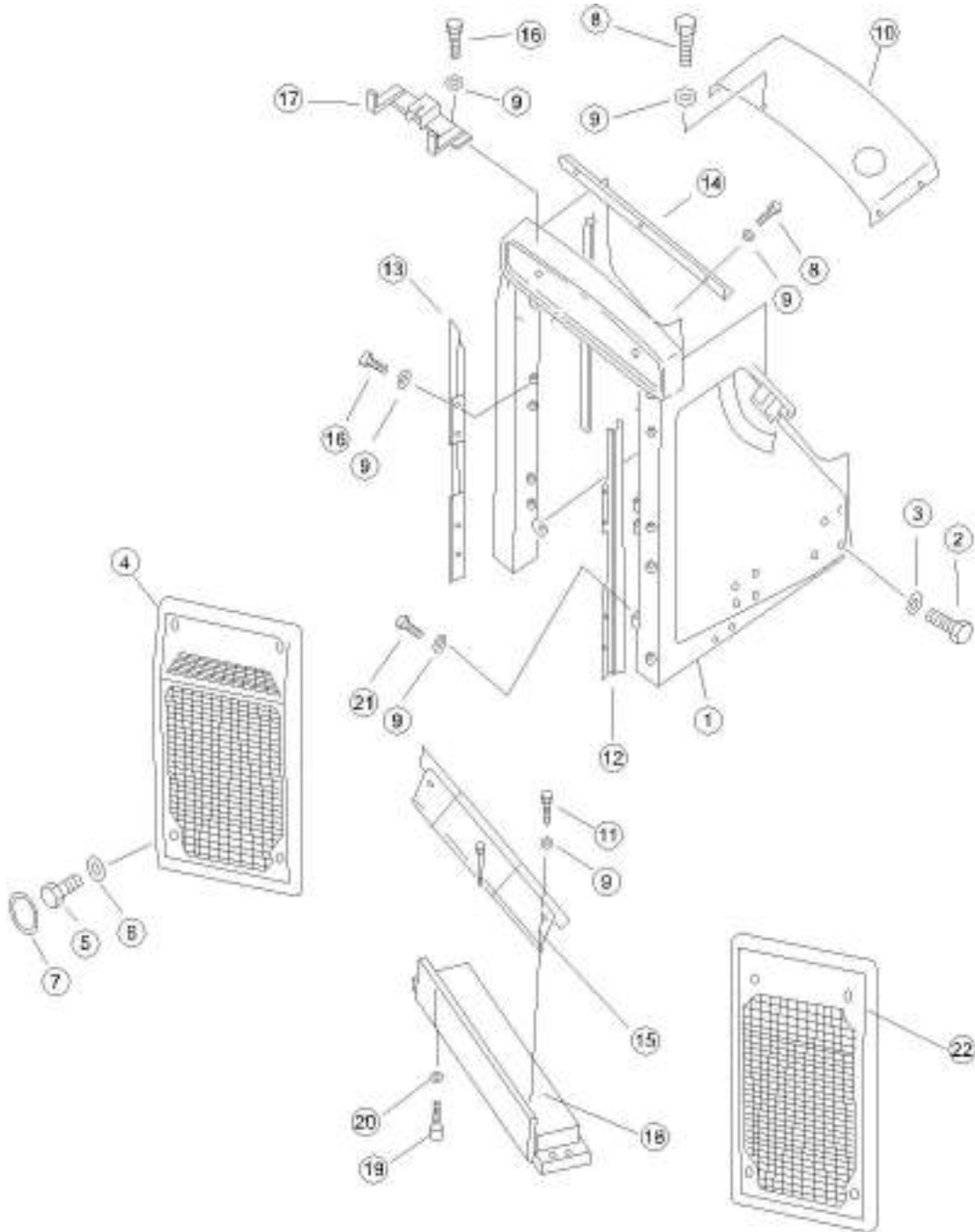

序号 NO.	部件号 PART NO.	零件名称 PART NAME		数量 Q'TY	适用机型 MODEL
1	171-50-01000	前机罩	Engine-hood, front	1	
2	01011-82750	螺栓 M27*150	Bolt M27*150	16	
3	01643-32780	垫圈 27	Washer 27	16	
4	171-50-10000	护栅	Guard fence	1	
5	01010-51650	螺栓 M16*50	Bolt M16*50	4	
6	01643-31645	垫圈 16	Washer 16	4	
7	23Y-50B-00003	帽	Cap	4	
8	01010-51225	螺栓 M12*25	Bolt M12*25	11	
9	01643-31232	垫圈 12	Washer 12	30	
10	171-50-02000	盖	Cover	1	
11	01010-51220	螺栓 M12*20	Bolt M12*20	3	
12	175-54-21822	左侧板	Side plate (L.H.)	1	
13	175-54-21832	右侧板	Side plate (R.H.)	1	
14	175-54-21318	板	Plate	1	
15	175-54-21325	板	Plate	1	
16	01010-51230	螺栓 M12*30	Bolt M12*30	12	
17	23Y-50B-10000	支座	Seat	2	
18	175-54-C1251	盖	Cover	1	
19	01010-52070	螺栓 M20*70	Bolt M20*70	4	
20	01643-32060	垫圈 20	Washer 20	4	
21	01010-51235	螺栓 M12*35	Bolt M12*35	4	
22	171-50-20000	护栅 ( 供沙特 )	Guard fence (For Saudi Arabia)	1	
22	171-50-30000	护栅	Guard fence	1	

# 发动机护罩 ENGINE GUARD

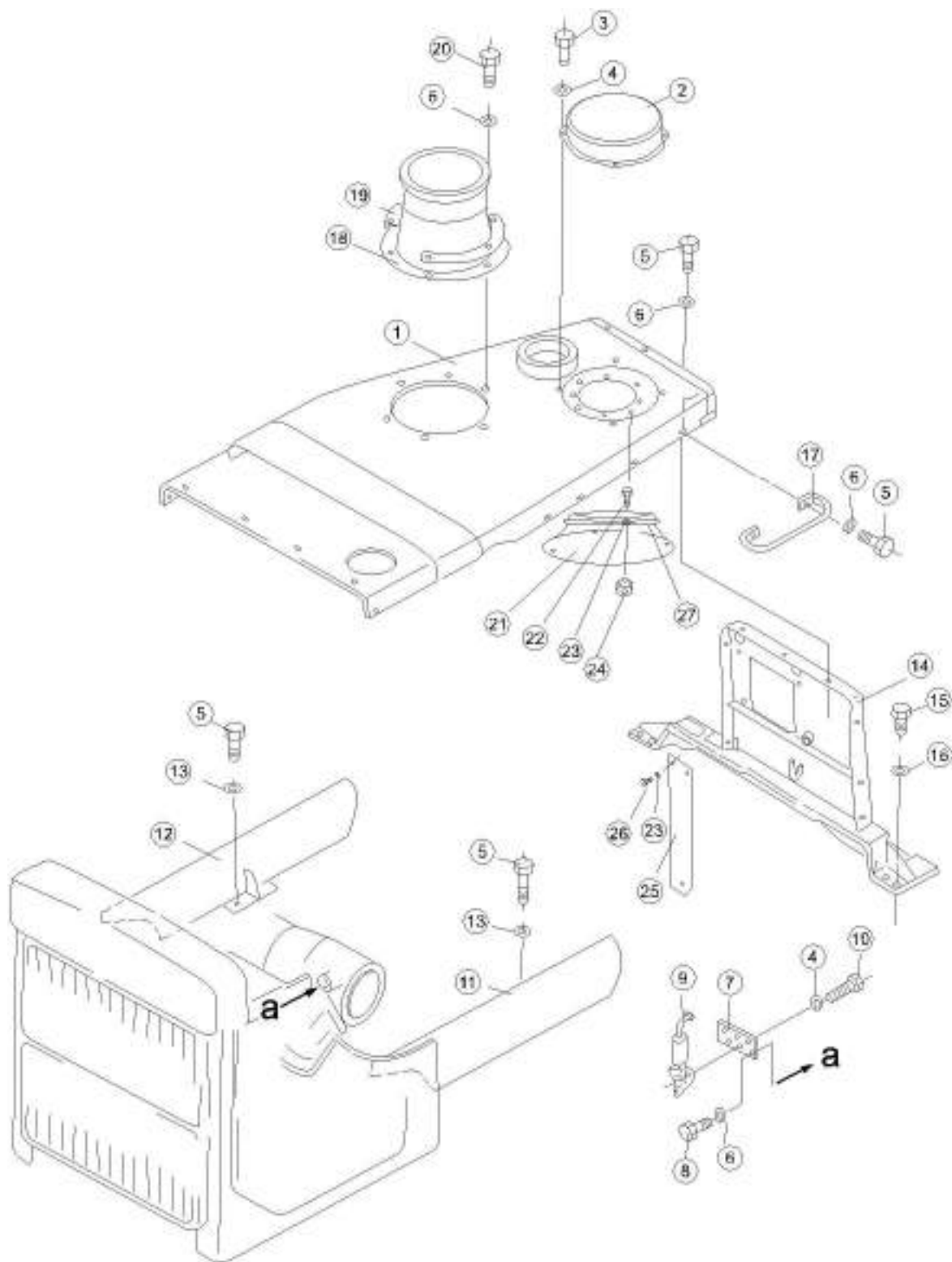

零件图册 | 护罩

序号 NO.	部件号 PART NO.	零件名称 PART NAME	数量 Q'TY	适用机型 MODEL
1	171-50-03000	上罩 Upper cover	1	
1	171-50-09000	上罩 ( 沙漠用 ) Lower cover (For desert)	1	
2	171-50-07000	罩 Cover	1	
3	01010-51020	螺栓 M10*20 Bolt M10*20	4	
4	01643-31032	垫圈 10 Washer 10	8	
5	01010-51235	螺栓 M12*35 Bolt M12*35	13	
6	01643-31232	垫圈 12 Washer 12	19	
7	175-54-21811	板 Plate	2	
8	01010-51230	螺栓 M12*30 Bolt M12*30	4	
9	175-54-21361	锁钩组件 Lock hook ass'y	2	
10	01010-51025	螺栓 M10*25 Bolt M10*25	4	
11	171-50-04000	盖 Cover	1	
12	171-50-05000	盖 Cover	1	
13	175-54-21340	垫圈 Washer	4	
14	171-50-08000	支架 Bracket	1	
15	01010-51645	螺栓 M16*45 Bolt M16*45	8	
16	01643-31645	垫圈 16 Washer 16	8	
17	09420-01903	扶手 Armrest	2	
18	171-50-06000	罩 Cover	1	
19	175-54-C1290	板 Plate	2	
20	01010-51245	螺栓 M12*45 Bolt M12*45	6	
21	171-50-11000	防尘套 Dust sleeve	1	
22	01010-50820	螺栓 M8*20 Bolt M8*20	8	
23	01643-30823	垫圈 8 Washer 8	11	
24	01580-10806	螺母 M8 Nut M8	8	
25	171-50-00003	板 ( 不装空调用 ) Plate (for use when no A/C is installed)	1	
26	01010-50835	螺栓 M8*35 Bolt M8*35	3	
27	07281-02429	喉箍 Hose Clamp	1	

## 散热器防护装置 (配国 II 发动机) RADIATOR GUARD (GOING WITH THE NATIONAL II-ENGINE)

此组件用于康明斯国 II  
NTAA855-C360S20 型发动机

This assembly is used for  
Cummins National II-NTAA855-  
C360S20 engine

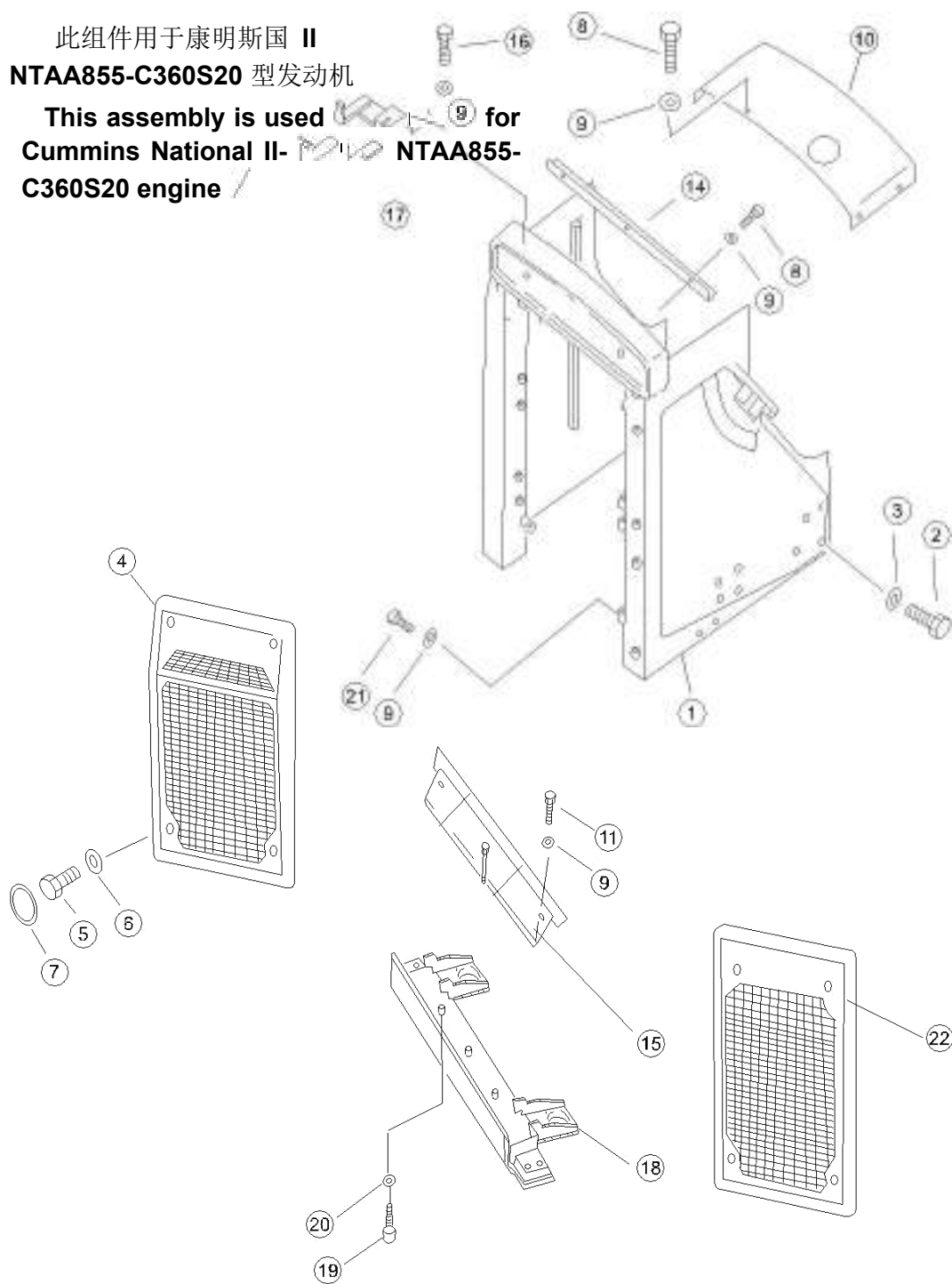

序号 NO.	部件号 PART NO.	零件名称 PART NAME		数量 Q'TY	适用机型 MODEL
1	171-50A-01000	前机罩	Engine-hood, front	1	
2	01011-82750	螺栓 M27*150	Bolt M27*150	16	
3	01643-32780	垫圈 27	Washer 27	16	
4	171-50-10000	护栅	Guard fence	1	
5	01010-51650	螺栓 M16*50	Bolt M16*50	4	
6	01643-31645	垫圈 16	Washer 16	4	
7	23Y-50B-00003	帽	Cap	4	
8	01010-51225	螺栓 M12*25	Bolt M12*25	11	
9	01643-31232	垫圈 12	Washer 12	22	
10	171-50A-02000	盖	Cover	1	
11	01010-51220	螺栓 M12*20	Bolt M12*20	3	
14	171-50A-05000	上护风罩	Upper shield	1	
15	171-50A-04000	下护风罩	Lower shield	1	
16	01010-51230	螺栓 M12*30	Bolt M12*30	4	
17	23Y-50B-10000	支座	Seat	2	
18	171-50A-03000	盖	Cover	1	
19	01010-52070	螺栓 M20*70	Bolt M20*70	4	
20	01643-32060	垫圈 20	Washer 20	4	
21	01010-51235	螺栓 M12*35	Bolt M12*35	4	
22	171-50-20000	护栅 ( 供沙特 )	Guard fence (For Saudi Arabia)	1	

## 发动机护罩（配国 II 发动机） ENGINE GUARD (GOING WITH THE NATIONAL II-ENGINE)

此组件用于康明斯国 II  
NTAA855-C360S20 型发动机  
This assembly is used  
for Cummins National II-  
NTAA855-C360S20 engine

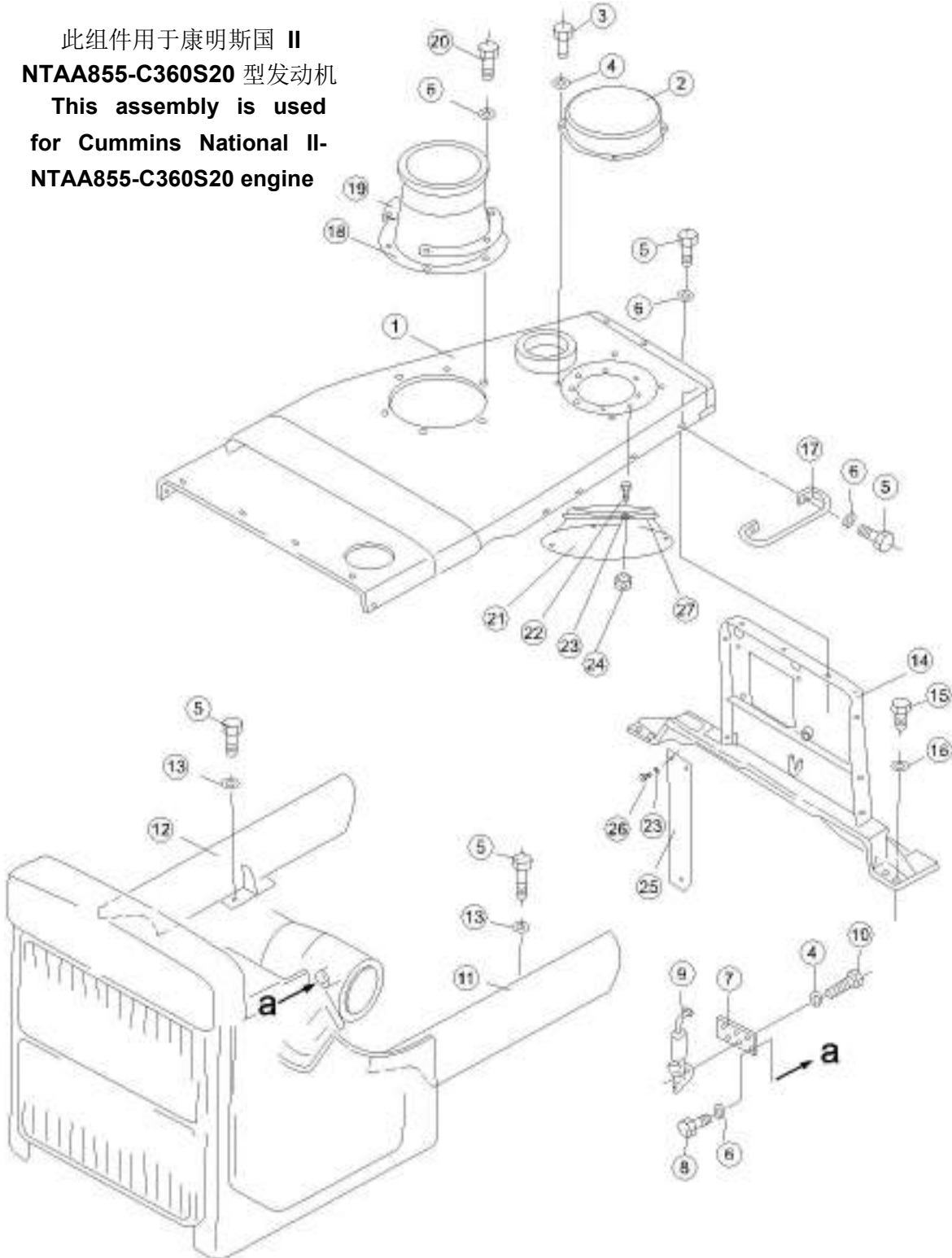

序号 NO.	部件号 PART NO.	零件名称 PART NAME	数量 Q'TY	适用机型 MODEL
1	171-50-03000	上罩 Upper cover	1	
1	171-50-09000	上罩 ( 沙漠用 ) Lower cover (For desert)	1	
2	171-50-07000	罩 Cover	1	
3	01010-51020	螺栓 M10*20 Bolt M10*20	4	
4	01643-31032	垫圈 10 Washer 10	8	
5	01010-51235	螺栓 M12*35 Bolt M12*35	13	
6	01643-31232	垫圈 12 Washer 12	19	
7	175-54-21811	板 Plate	2	
8	01010-51230	螺栓 M12*30 Bolt M12*30	4	
9	175-54-21361	锁钩组件 Lock hook ass'y	2	
10	01010-51025	螺栓 M10*25 Bolt M10*25	4	
11	171-50-04000	盖 Cover	1	
12	171-50-05000	盖 Cover	1	
13	175-54-21340	垫圈 Washer	4	
14	171-50-08000	支架 Bracket	1	
15	01010-51645	螺栓 M16*45 Bolt M16*45	8	
16	01643-31645	垫圈 16 Washer 16	8	
17	09420-01903	扶手 Armrest	2	
18	171-50-06000	罩 Cover	1	
19	175-54-C1290	板 Plate	2	
20	01010-51245	螺栓 M12*45 Bolt M12*45	6	
21	171-50-11000	防尘套 Dust sleeve	1	
22	01010-50820	螺栓 M8*20 Bolt M8*20	8	
23	01643-30823	垫圈 8 Washer 8	11	
24	01580-10806	螺母 M8 Nut M8	8	
25	171-50-00003	板 ( 不装空调用 ) Plate (for use when no A/C is installed)	1	
26	01010-50835	螺栓 M8*35 Bolt M8*35	3	
27	07281-02429	喉箍 Hose Clamp	1	

# 翼板 FENDER

带防翻滚支架  
With R.O.P.S

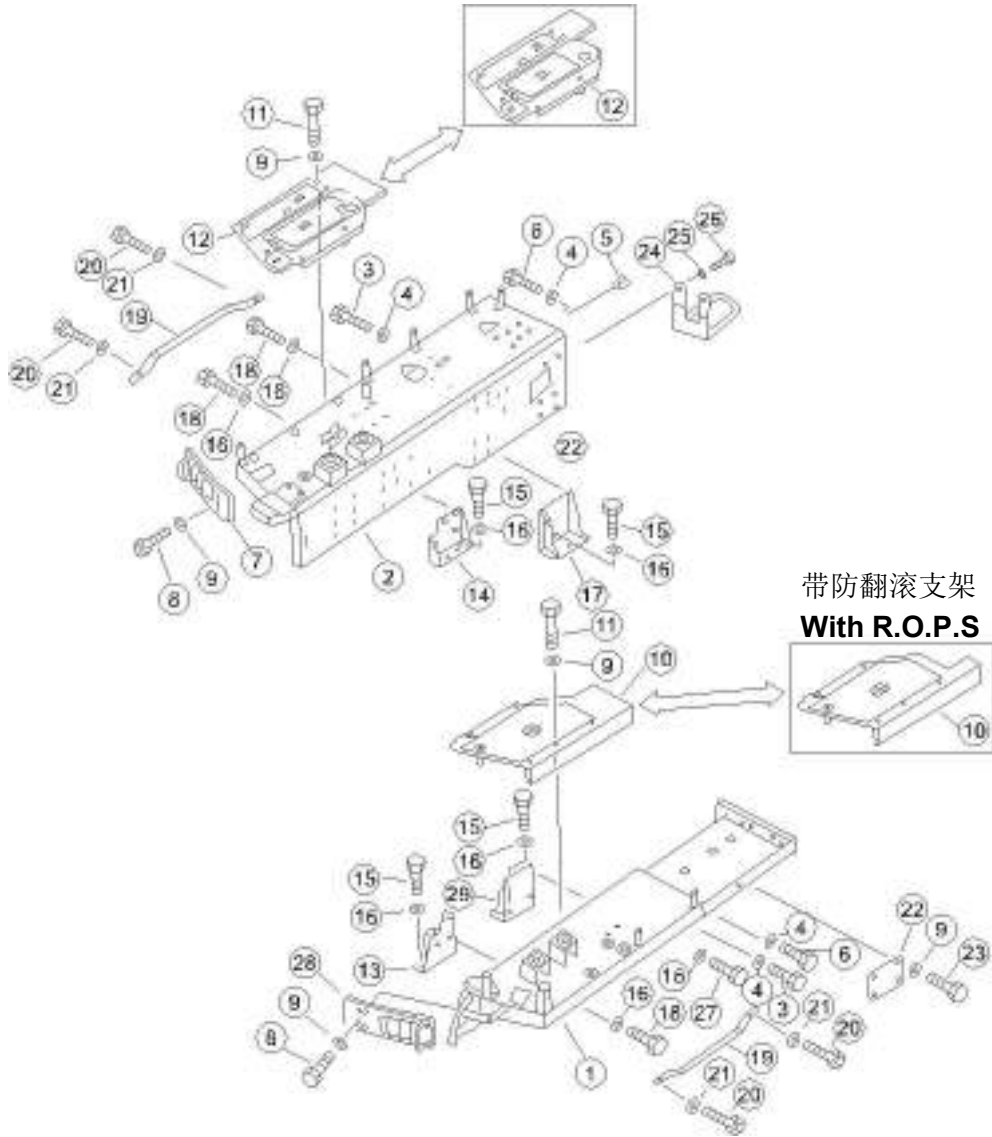

序号 NO.	部件号 PART NO.	零件名称 PART NAME	数量 Q'TY	适用机型 MODEL
1	171-51-14000	左翼板 Fender (L.H.)	1	
2	171-51-11000	右翼板 Fender (R.H.)	1	
3	01010-52450	螺栓 M24*50 Bolt M24*50	8	
4	01643-32460	垫圈 24 Washer 24	16	
5	07049-02430	防尘塞 Plug, Dust	10	
6	01010-52465	螺栓 M24*65 Bolt M24*65	8	
7	171-51-01000	右灯罩 Lamp cover (R.H.)	1	
8	01010-51225	螺栓 M12*25 Bolt M12*25	8	
9	01643-31232	垫圈 12 Washer 12	28	
10	171-51-20000	盖 Cover	1	
10	171-51-21000	盖 (装防翻滚架用) Cover (Used for installing R.O.P.S)	1	
11	01011-51275	螺栓 M12*175 Bolt M12*175	12	
12	171-51-02000	盖 Cover	1	
12	171-51-03000	盖 (装防翻滚架用) Cover (Used for installing R.O.P.S)	1	
13	175-54-26255	支架 Bracket	1	
14	175-54-26272	支架 Bracket	1	
15	01010-51655	螺栓 M16*55 Bolt M16*55	16	
16	01643-31645	垫圈 16 Washer 16	36	
17	175-54-34110	右支架 Bracket (R.H.)	1	
18	01010-51645	螺栓 M16*45 Bolt M16*45	16	
19	175-54-22840	拉手 Handle	2	
20	01010-51445	螺栓 M14*45 Bolt M14*45	4	
21	01643-31445	垫圈 14 Washer 14	4	
22	175-54-22420	盖 Cover	2	
23	01010-51235	螺栓 M12*35 Bolt M12*35	8	
24	195-54-23991	踏板 Pedal	2	
25	01010-51850	螺栓 M18*50 Bolt M18*50	8	
26	01643-31845	垫圈 18 Washer 18	8	
27	01010-51640	螺栓 M16*40 Bolt M16*40	4	
28	171-51-22000	左灯罩 Lamp cover (L.H.)	1	
29	175-54-26263	左支架 Bracket (L.H.)	1	

# 支撑架 SUPPORT

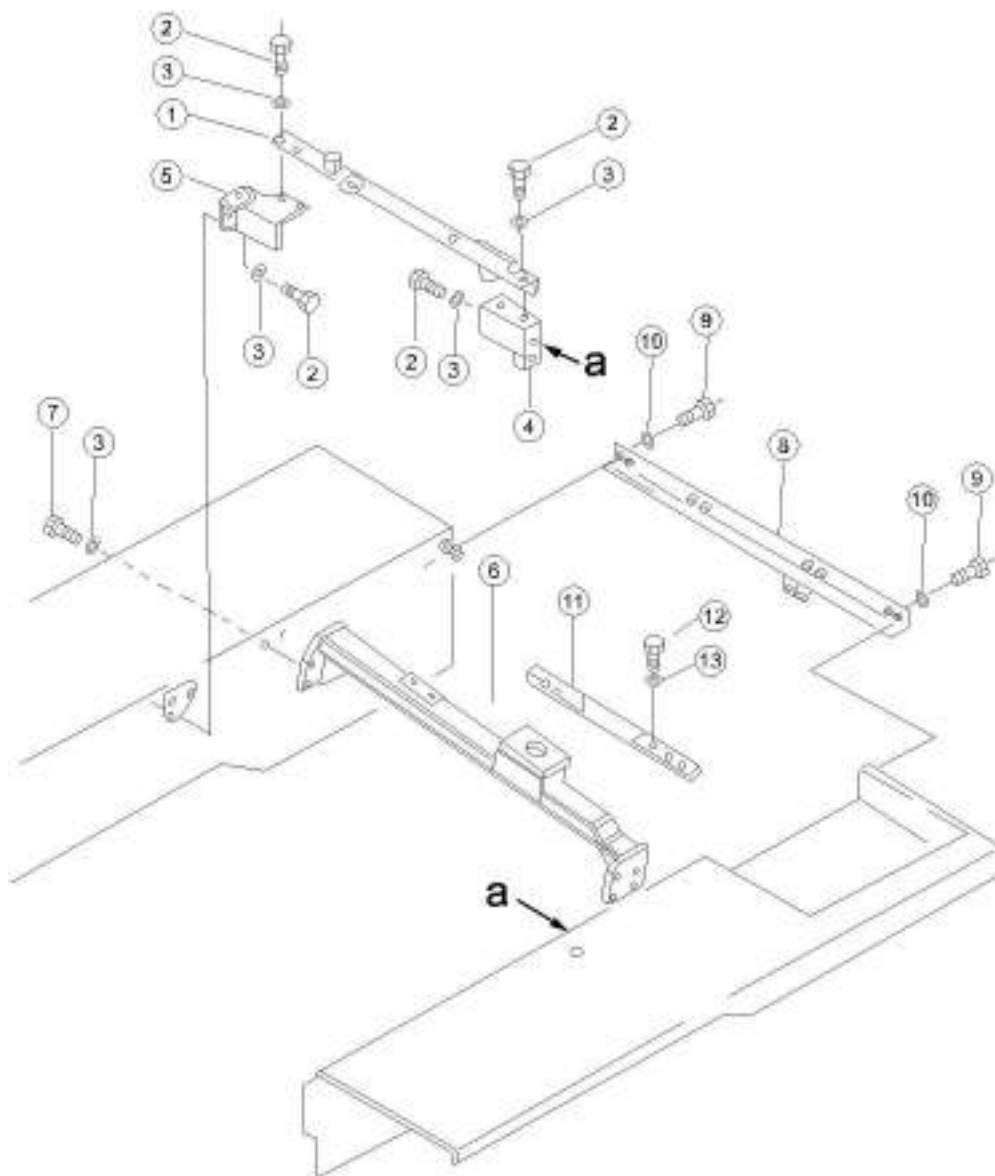

序号 NO.	部件号 PART NO.	零件名称 PART NAME	数量 Q'TY	适用机型 MODEL
1	175-54-33884	支架 Bracket	1	
2	01010-51635	螺栓 M16*35 Bolt M16*35	9	
3	01643-31645	垫圈 16 Washer 16	17	
4	175-54-33892	支架 Bracket	1	
5	175-54-33981	支架 Bracket	1	
6	171-51-31000	支架 Bracket	1	
7	01010-51645	螺栓 M16*45 Bolt M16*45	8	
8	175-54-22196	拉条 Bar	1	
9	01010-51230	螺栓 M12*30 Bolt M12*30	2	
10	01643-31232	垫圈 12 Washer 12	2	
11	171-51-12000	支架 Bracket	1	
12	01010-51225	螺栓 M12*25 Bolt M12*25	2	
13	01602-21236	垫圈 12 Washer 12	2	

后盖  
COVER, REAR

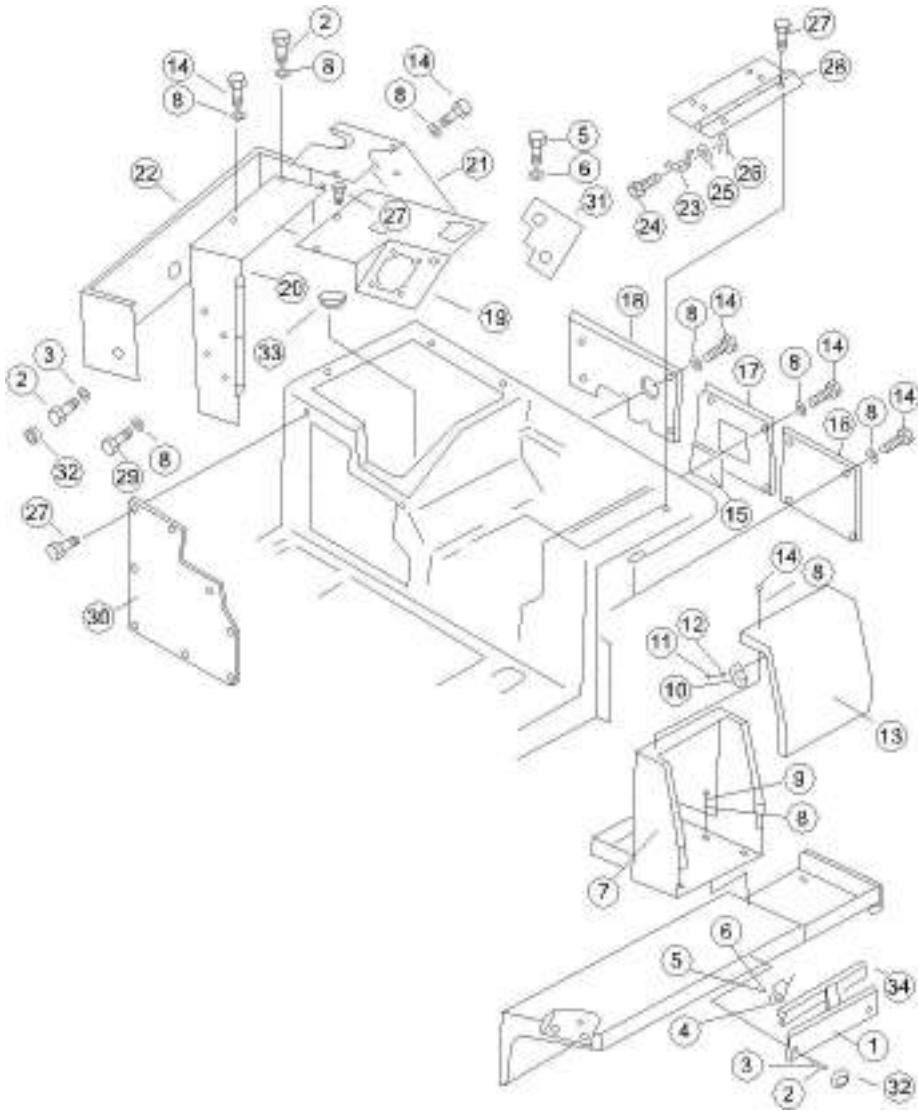

序号 NO.	部件号 PART NO.	零件名称 PART NAME	数量 Q'TY	适用机型 MODEL
1	171-51-25000	盖 Cover	1	
2	01010-51225	螺栓 M12*25 Bolt M12*25	8	
3	124-54-26540	垫圈 Washer	7	
4	154-54-46150	支架 Bracket	1	
5	01010-51025	螺栓 M10*25 Bolt M10*25	4	
6	01643-31032	垫圈 10 Washer 10	4	
7	171-51-26000	支架 Bracket	1	
8	01643-31232	垫圈 12 Washer 12	28	
9	01580-11210	螺母 Nut	4	
10	198-54-19150	卡簧 Retainer	1	
11	01010-50612	螺栓 M6*12 Bolt M6*12	2	
12	01643-30623	垫圈 6 Washer 6	2	
13	171-51-17000	蓄电池罩 Battery cover	1	
14	01010-51230	螺栓 M12*30 Bolt M12*30	19	
15	24Y-50-02000	盖 Cover	1	
16	175-54-33861	盖 Cover	1	
17	175-54-33851	盖 Cover	1	
18	175-54-33871	盖 Cover	1	
19	171-51-27000	盖板 (装松土器用) Cover plate (For installation ripper)	1	
19	171-51-08000	盖板 Cover plate	1	
20	171-51-06000	护板 Guard plate	1	
21	171-51-09000	护板 Guard plate	1	
21	171-51-10000	护板 (装松土器用) Guard plate (For installation ripper)	1	
22	171-51-07000	护板 Guard plate	1	
23	120-54-12210	弹簧 Spring	2	
24	04205-10620	销轴 Pin shaft	2	
25	01641-20608	垫圈 6 Washer 6	2	
26	04050-01610	开口销 Cotter pin	2	
27	195-54-26210	螺钉 Screw	17	
28	171-51-16000	盖 Cover	1	
29	01010-51295	螺栓 M12*95 Bolt M12*95	4	
30	171-51-32000	板 Plate	1	
31	171-51-00004	盖板 Cover plate	1	
32	198-54-41941	帽 Cap	7	
33	16Y-51C-00010	帽 Cap	1	
34	171-51-00006	密封条 Seal strip	2	

# 地板架 FRAME, FLOOR PLATE

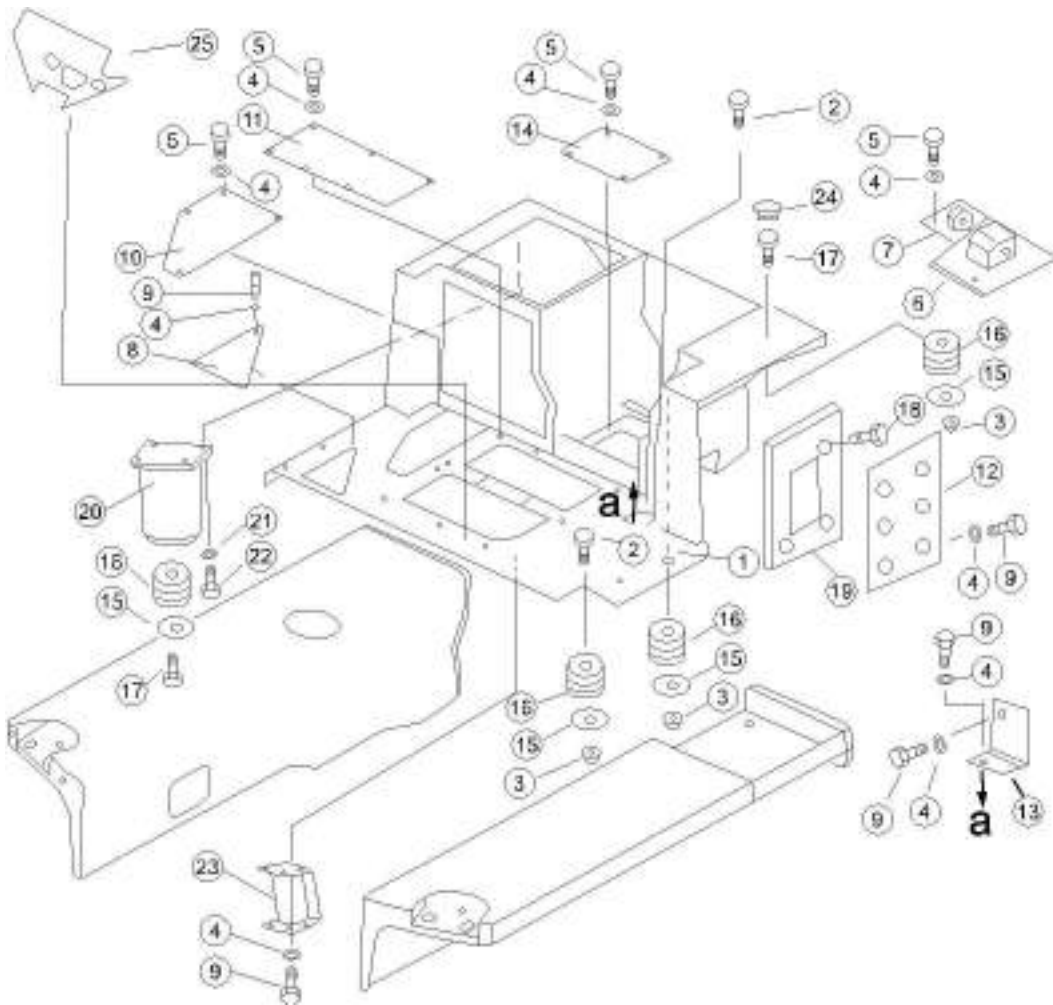

序号 NO.	部件号 PART NO.	零件名称 PART NAME		数量 Q'TY	适用机型 MODEL
1	171-51-04000	地板架	Floor frame	1	
2	01011-52045	螺栓 M20*145	Bolt M20*145	5	
3	01580-12016	螺母 M20	Nut M20	6	
4	01643-31032	垫圈 10	Washer 10	44	
5	01010-51035	螺栓 M10*35	Bolt M10*35	23	
6	171-51-19000	支架	Bracket	1	
7	171-51-30000	支架	Bracket	1	
8	171-51-00001	盖板	Cover plate	1	
9	01010-51025	螺栓 M10*25	Bolt M10*25	21	
10	171-51-05000	盖板	Cover plate	1	
11	171-51-18000	盖	Cover	1	
12	171-51-00003	板	Plate	2	
13	171-51-00002	板	Plate	1	
14	171-51-13000	盖	Cover	1	
15	23Y-51B-00010	垫圈	Washer	7	
16	23Y-51B-24000	减震座	Damping seat	7	
17	01011-52025	螺栓 M20*125	Bolt M20*125	2	
18	01023-30610	螺钉 M6*10	Screw M6*10	2	
19	171-51-28000	盖板	Cover plate	1	
20	171-51-15000	支架	Bracket	1	
21	01643-31232	垫圈 12	Washer 12	4	
22	01010-51230	螺栓 M12*30	Bolt M12*30	4	
23	171-51-29000	支架	Bracket	1	
24	171-51-00005	帽	Cap	1	
25	171-51-33000	地板垫	Pad, Floor plate	1	

# 发动机侧护罩 ENGINE GUARD, SIDE

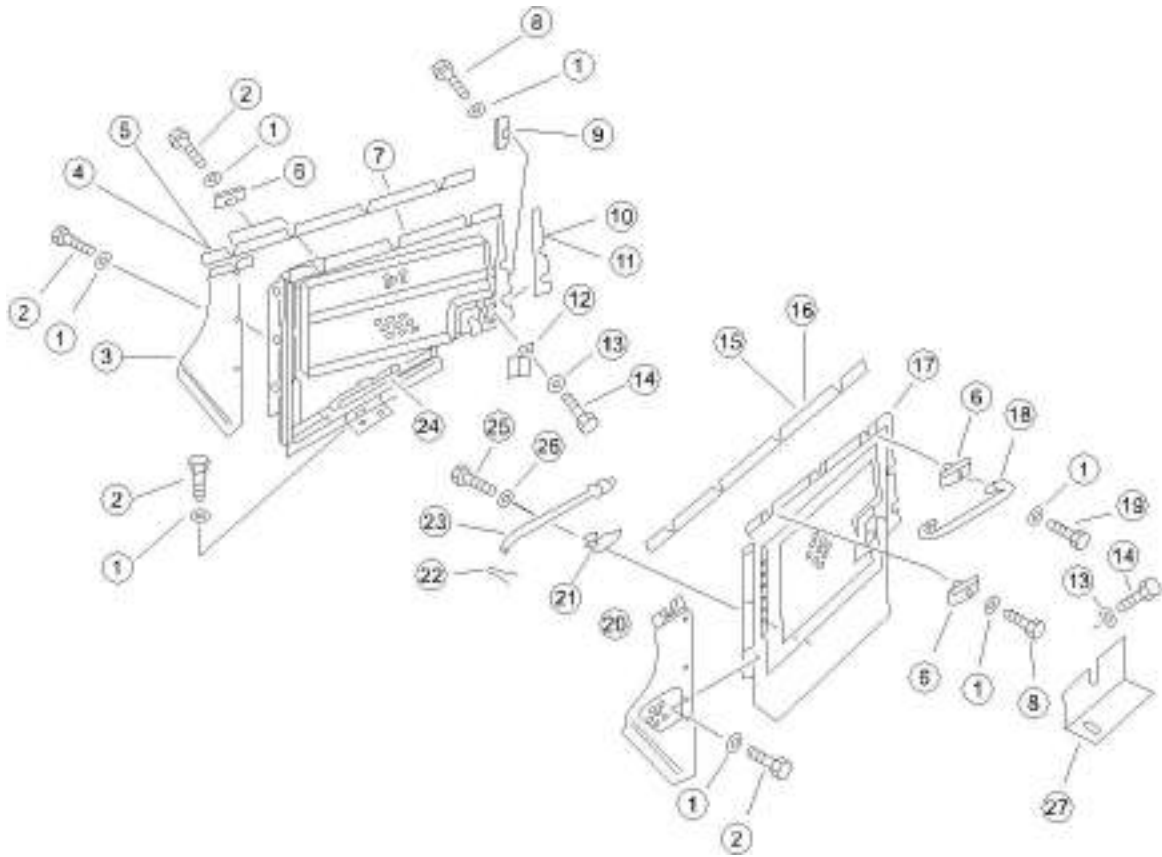

序号 NO.	部件号 PART NO.	零件名称 PART NAME		数量 Q'TY	适用机型 MODEL
1	01643-31232	垫圈 12	Washer 12	24	
2	01010-51235	螺栓 M12*35	Bolt M12*35	14	
3	24M-54-24000	板	Plate	1	
4	171-54-00001	压板	Binder plate	1	
5	171-54-00002	压板	Binder plate	1	
6	23Y-54-13000	压块	Block	10	
7	171-54-02000	右护罩	Guard (R.H.)	1	
8	01010-51255	螺栓 M12*55	Bolt M12*55	6	
9	24M-54-10004	压板	Binder plate	2	
10	24M-54-20003	橡胶垫	Rubber pad	1	
11	24M-54-10003	橡胶垫	Rubber pad	1	
12	23Y-54B-05000	支架	Bracket	2	
13	01643-31032	垫圈 10	Washer 10	5	
14	01010-51020	螺栓 M10*20	Bolt M10*20	5	
15	171-54-00003	橡胶垫	Rubber pad	1	
16	171-54-00004	橡胶垫	Rubber pad	1	
17	171-54-01000	左护罩	Guard (L.H.)	1	
18	09420-01903	扶手	Armrest	2	
19	01010-51265	螺栓 M12*65	Bolt M12*65	4	
20	24M-54-11000	板	Plate	1	
21	198-54-19150	卡簧	Retainer	2	
22	04050-12016	开口销	Cotter pin	2	
23	154-54-43240	杆 ( 左 )	Lever (L.H.)	1	
24	154-54-43250	杆 ( 右 )	Lever (R.H.)	1	
25	01010-50612	螺栓 M6*12	Bolt M6*12	4	
26	01643-30623	垫圈 6	Washer 6	4	
27	171-54-03000	板	Plate	1	

# 底护板总成 BOTTOM GUARD PLATE ASS'Y

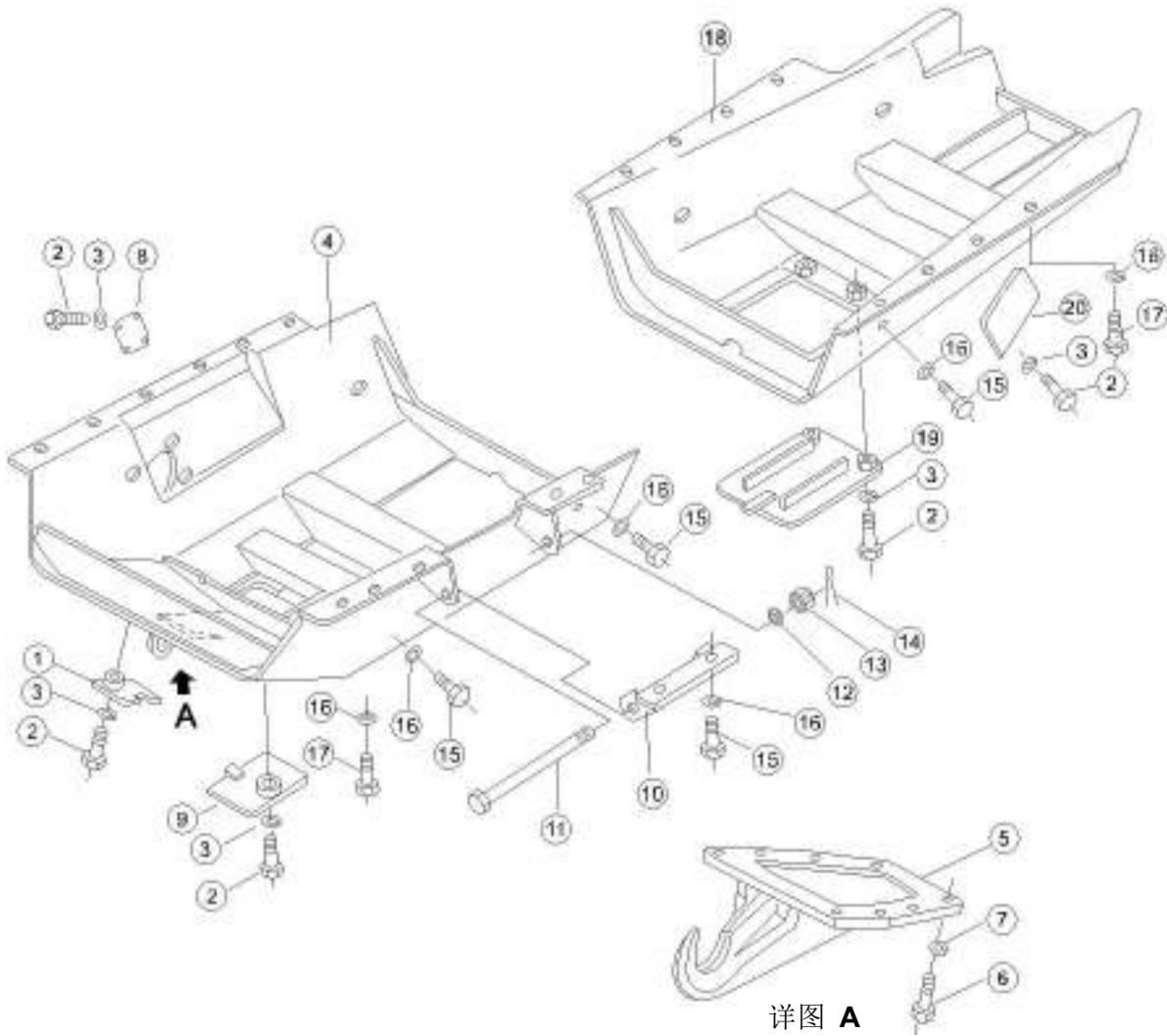

详图 A  
Detail A

零件图册 | 护罩

序号 NO.	部件号 PART NO.	零件名称 PART NAME	数量 Q'TY	适用机型 MODEL
1	175-54-23230	盖 Cover	1	
2	01010-51235	螺栓 M12*35 Bolt M12*35	10	
3	01643-31232	垫圈 12 Washer 12	10	
4	175-54-C1261	前底护板 Bottom guard plate (Front)	1	
5	180-54-13160	钩 Hook	1	
6	01010-52075	螺栓 M20*75 Bolt M20*75	8	
7	01643-32060	垫圈 20 Washer 20	8	
8	24Y-50-00001	盖板 Cover plate	2	
9	175-54-C1270	盖 Cover	1	
10	175-54-23461	托架 Bracket	1	
11	175-54-23471	螺栓 Bolt	1	
12	01640-23045	垫圈 30 Washer 30	1	
13	01590-33033	螺母 M30*3 Nut M30*3	1	
14	04050-16355	开口销 Cotter pin	1	
15	01010-52455	螺栓 M24*55 Bolt M24*55	10	
16	01643-32460	垫圈 24 Washer 24	28	
17	01010-52465	螺栓 M24*65 Bolt M24*65	18	
18	175-54-23169	后底护板 Bottom guard plate (Rear)	1	
19	175-54-23220	盖 Cover	1	
20	24Y-50-01000	盖 Cover	1	

# 油缸支撑 OIL CYLINDER SUPPORT

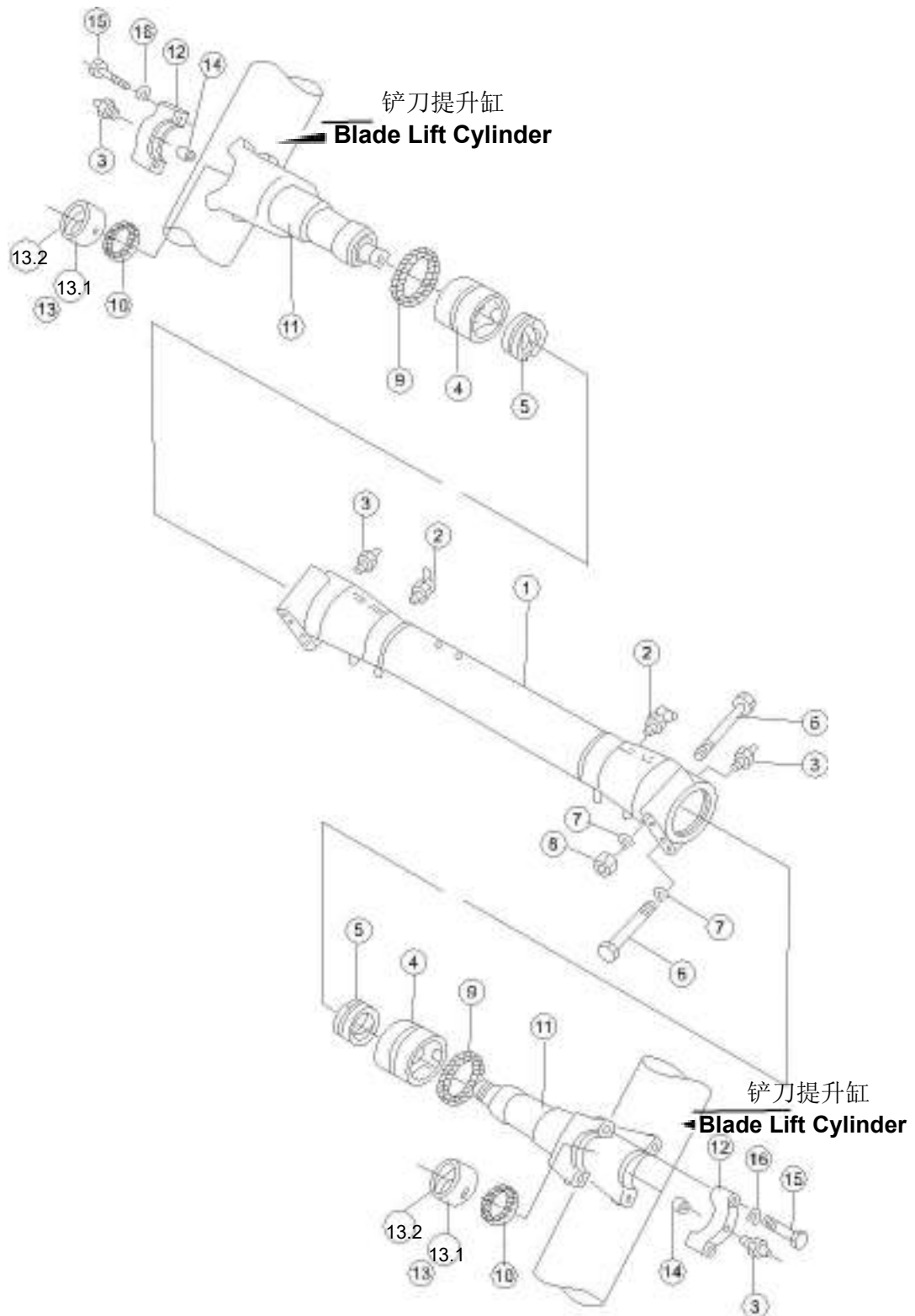

序号 NO.	部件号 PART NO.	零件名称 PART NAME		数量 Q'TY	适用机型 MODEL
1	175-61-C1110	撑杆	Support rod	1	
2	07021-01060	油杯 60° M10*1	Oil cup 60° M10*1	2	
3	07020-01021	油杯 M10*1	Oil cup M10*1	6	
4	175-61-15140	轴套	Sleeve	2	
5	175-61-15151	轴套	Sleeve	2	
6	175-61-15130	螺栓	Bolt	8	
7	01602-22783	垫圈 27	Washer 27	8	
8	01580-12722	螺母 M27	Nut M27	4	
9	07145-00125	防尘圈	Ring, Dust	2	
10	07145-00085	防尘圈	Ring, Dust	4	
11	175-61-12114	座	Seat	2	
12	175-60-19121	盖	Cover	4	
13.20	175-60-19141	堵	Plug	4	
13.10	175-61-12121	轴瓦	Bushing	4	
13	175-61-15201	轴瓦	Bushing	4	
14	175-70-15190	销轴	Pin shaft	4	
15	01010-51890	螺栓 M18*90	Bolt M18*90	8	
16	01602-21854	垫圈 18	Washer 18	8	

# 油缸支撑 ( 配国 II 发动机 ) OIL CYLINDER SUPPORT ( GOING WITH THE NATIONAL II-ENGINE )

此组件用于康明斯国 II  
NTAA855-C360S20 型发动机  
This assembly is used  
for Cummins National II-  
NTAA855-C360S20 engine

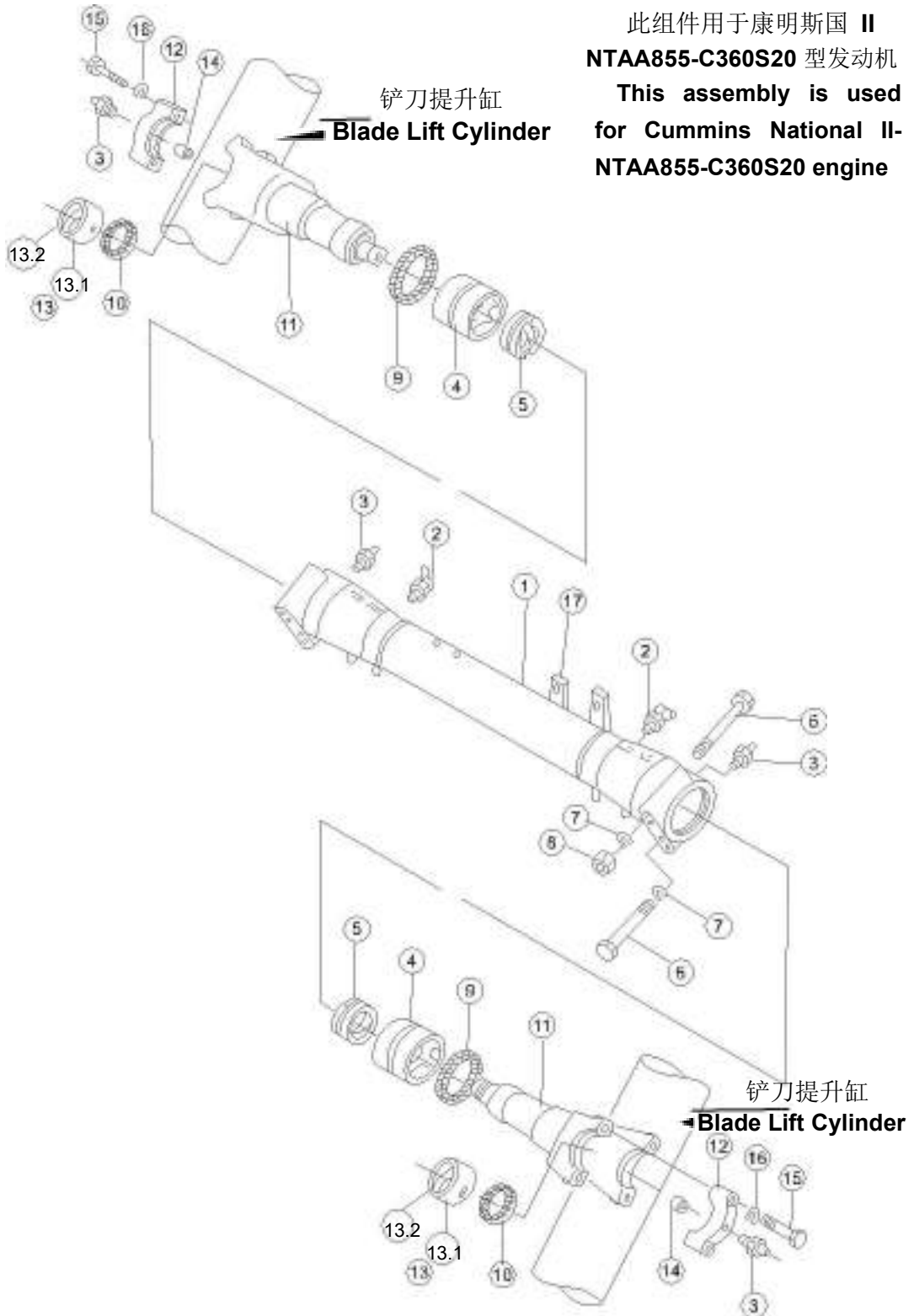

序号 NO.	部件号 PART NO.	零件名称 PART NAME		数量 Q'TY	适用机型 MODEL
1	171-85A-01000	撑杆	Support rod	1	
2	07021-01060	油杯 60° M10*1	Oil cup 60° M10*1	2	
3	07020-01021	油杯 M10*1	Oil cup M10*1	6	
4	175-61-15140	轴套	Sleeve	2	
5	175-61-15151	轴套	Sleeve	2	
6	175-61-15130	螺栓	Bolt	8	
7	01602-22783	垫圈 27	Washer 27	8	
8	01580-12722	螺母 M27	Nut M27	4	
9	07145-00125	防尘圈	Ring, Dust	2	
10	07145-00085	防尘圈	Ring, Dust	4	
11	175-61-12114	座	Seat	2	
12	175-60-19121	盖	Cover	4	
13.20	175-60-19141	堵	Plug	4	
13	175-61-15201	轴瓦	Bushing	4	
13.10	175-61-12121	轴瓦	Bushing	4	
14	175-70-15190	销轴	Pin shaft	4	
15	01010-51890	螺栓 M18*90	Bolt M18*90	8	
16	01602-21854	垫圈 18	Washer 18	8	
17	171-85A-01001	座	Seat	2	

A series of horizontal dashed lines for writing notes.

工作装置控制系统

**WORK EQUIPMENT CONTROL SYSTEM**

# 铲刀升降油缸 BLADE LIFT CYLINDER

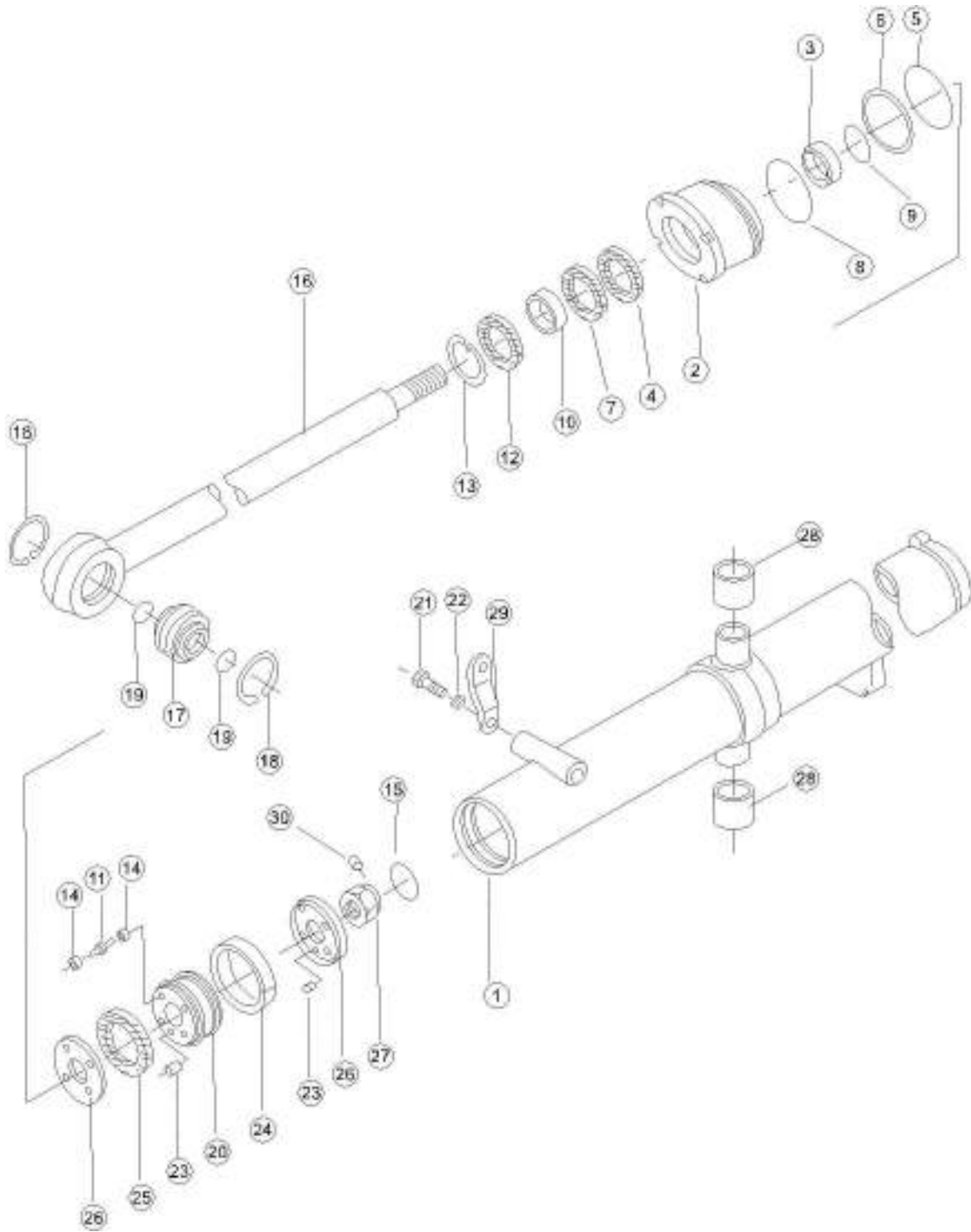

序号 NO.	部件号 PART NO.	零件名称 PART NAME	数量 Q'TY	适用机型 MODEL
1	171-62-01400	缸体 Cylinder body	1	
2	171-62-01003	缸头 Cylinder head	1	
3	07177-07530	衬套 Bushing	1	
4	171-62-01200	斯特封 Step seal	1	
5	07000-12135	O-型圈 O-ring	1	
6	171-62-01002	保护圈 Guard ring	1	
7	707-51-75110	密封圈 Seal ring	1	
8	07000-12140	O形圈 O-ring	1	
9	GB895.1-80	挡圈 Retainer ring	1	
10	07177-07515	衬套 Bushing	1	
11	175-63-12550	活塞 Piston	4	
12	171-62-01100	防尘圈 Ring, Dust	1	
13	07179-00097	弹性挡环 Retainer	1	
14	175-63-12650	阀座 Valve seat	8	
15	01322-40825	紧定螺钉 Set screw	1	
16	171-62-01500	活塞杆 Piston rod	1	
17	07137-05008	向心关节轴承 Spherical Plain Bearing	1	
18	04065-01110	挡圈 Retainer ring	2	
19	07000-13050	O形圈 O-ring	2	
20	175-63-92662	活塞 Piston	1	
21	01010-51245	螺栓 M12*45 Bolt M12*45	1	
22	01643-31232	垫圈 12 Washer 12	1	
23	04020-00616	圆柱销 Cylindrical pin	2	
24	07155-01435	修整圈 Trim ring	1	
25	707-44-14080	活塞密封圈 Piston ring	1	
26	175-63-12352	挡圈 Retainer ring	2	
27	171-62-01001	螺母 Nut	1	
28	175-63-12540	衬套 Bushing	2	
29	175-63-12370	板 Plate	1	
30	04059-01020	铁丝 Iron wire	1	

# 倾斜油缸 TILT OIL CYLINDER

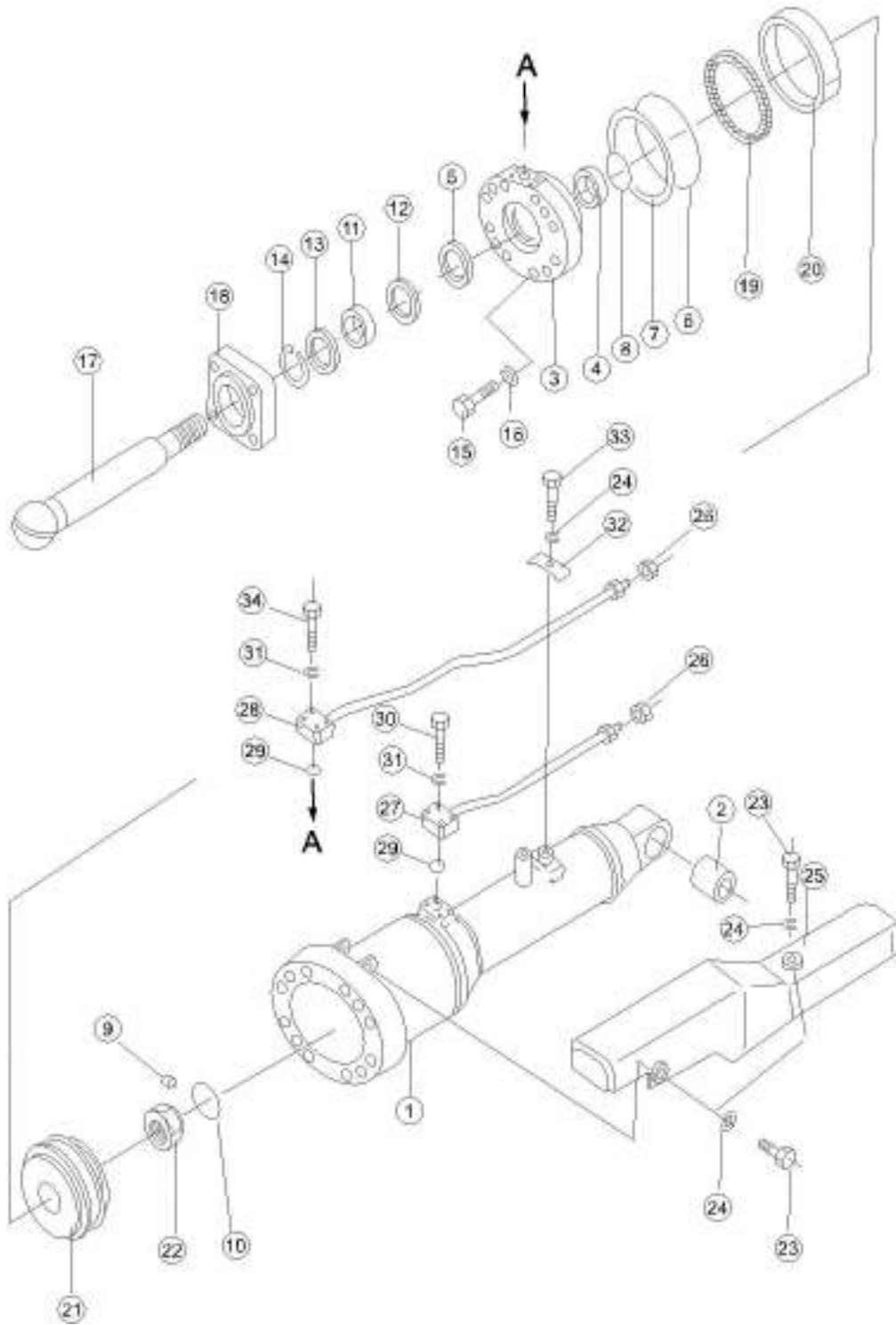

序号 NO.	部件号 PART NO.	零件名称 PART NAME	数量 Q'TY	适用机型 MODEL
1	171-63-01100	缸体 Cylinder body	1	
2	195-63-52160	衬套 Bushing	1	
3	171-63-01001	缸头 Cylinder head	1	
4	07177-09035	衬套 Bushing	1	
5	171-63-01300	斯特封 Step seal	1	
6	07000-15215	O 形圈 O-ring	1	
7	07001-05220	保护圈 Guard ring	1	
8	GB895.1-95	挡圈 Retainer ring	1	
9	01322-41025	紧定螺钉 Set screw	1	
10	04059-01030	铁丝 Iron wire	1	
11	07177-09020	衬套 Bushing	1	
12	171-63-01005	KY 圈 KY-Ring	1	
13	171-63-01400	防尘圈 Ring, Dust	1	
14	07179-00113	弹性挡环 Retainer	1	
15	01252-42090	螺栓 M20*90 Bolt M20*90	12	
16	01643-32060	垫圈 20 Washer 20	12	
17	171-63-01500	活塞杆 Piston rod	1	
18	175-71-11211	盖 Cover	1	
19	707-44-22080	活塞密封圈 Piston ring	1	
20	07155-02250	修整圈 Trim ring	1	
21	171-63-01003	活塞 Piston	1	
22	171-63-01004	螺母 Nut	1	
23	01010-51440	螺栓 M14*40 Bolt M14*40	3	
24	01643-31445	垫圈 14 Washer 14	3	
25	175-63-52572	罩 Cover	1	
26	195-63-52990	螺塞 Screw plug	2	
27	175-63-52552	油管 Oil tube	1	
28	171-63-01200	管子 Tube	1	
29	07000-13035	O 形圈 O-ring	2	
30	01010-51050	螺栓 M10*50 Bolt M10*50	4	
31	01643-31032	垫圈 10 Washer 10	8	
32	195-63-52871	弓形夹 Bow-shaped clip	1	
33	01010-51420	螺栓 M14*20 Bolt M14*20	1	
34	01010-51065	螺栓 M10*65 Bolt M10*65	4	

# 工作油泵总成 WORK PUMP ASS'Y

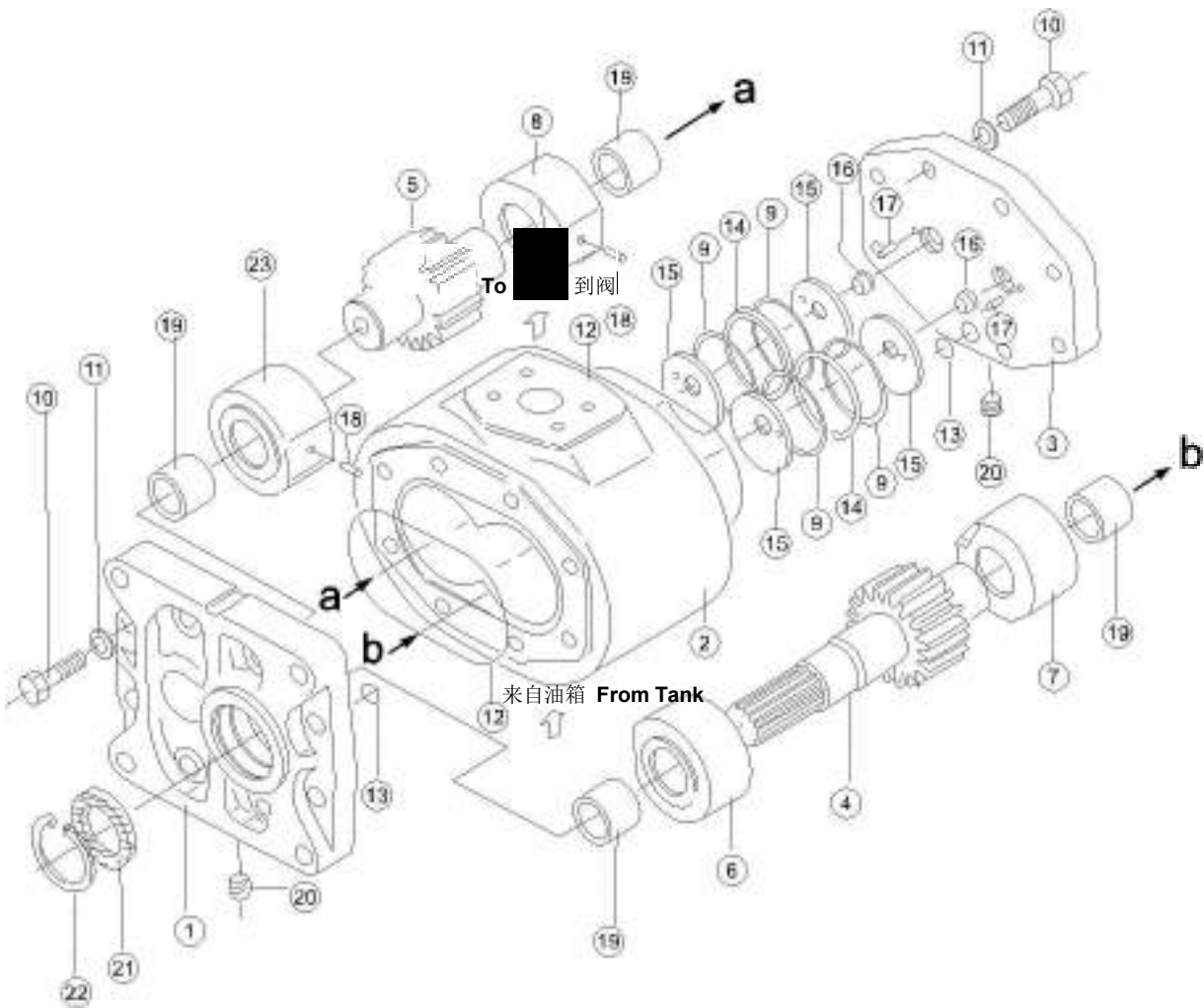

序号 NO.	部件号 PART NO.	零件名称 PART NAME		数量 Q'TY	适用机型 MODEL
1	07445-66011	托架	Bracket	1	
2	07446-66020	泵壳	Body, Pump	1	
3	07445-66030	泵盖	Cover, Pump	1	
4	07446-66040	主动齿轮	Driving gear	1	
5	07446-66050	从动齿轮	Driven gear	1	
6	07445-66760	衬套	Bushing	1	
7	07445-66770	衬套	Bushing	1	
8	07445-66870	衬套	Bushing	1	
9	07445-66091	保护圈	Guard ring	4	
10	01010-51655	螺栓 M16*55	Bolt M16*55	16	
11	01602-21648	垫圈 16	Washer 16	16	
12	07443-66140	O 形圈	O-ring	2	
13	07000-12015	O 形圈	O-ring	2	
14	07443-66736	U 形环	U-ring	2	
15	07445-66130	封板	Plate, Seal	2	
16	07438-66090	环	Ring	2	
17	04025-00412	圆柱销	Cylindrical pin	2	
18	07445-66171	销子	Pin	2	
19	07445-66181	滚针轴承	Needle Roller Bearing	4	
20	07043-70211	螺塞	Screw plug	2	
21	07443-11163	油封	Oil seal	1	
22	04065-06525	挡圈	Retainer ring	1	
23	07445-66860	衬套	Bushing	1	

# 工作油箱 (1/2) HYDRAULIC TANK (1/2)

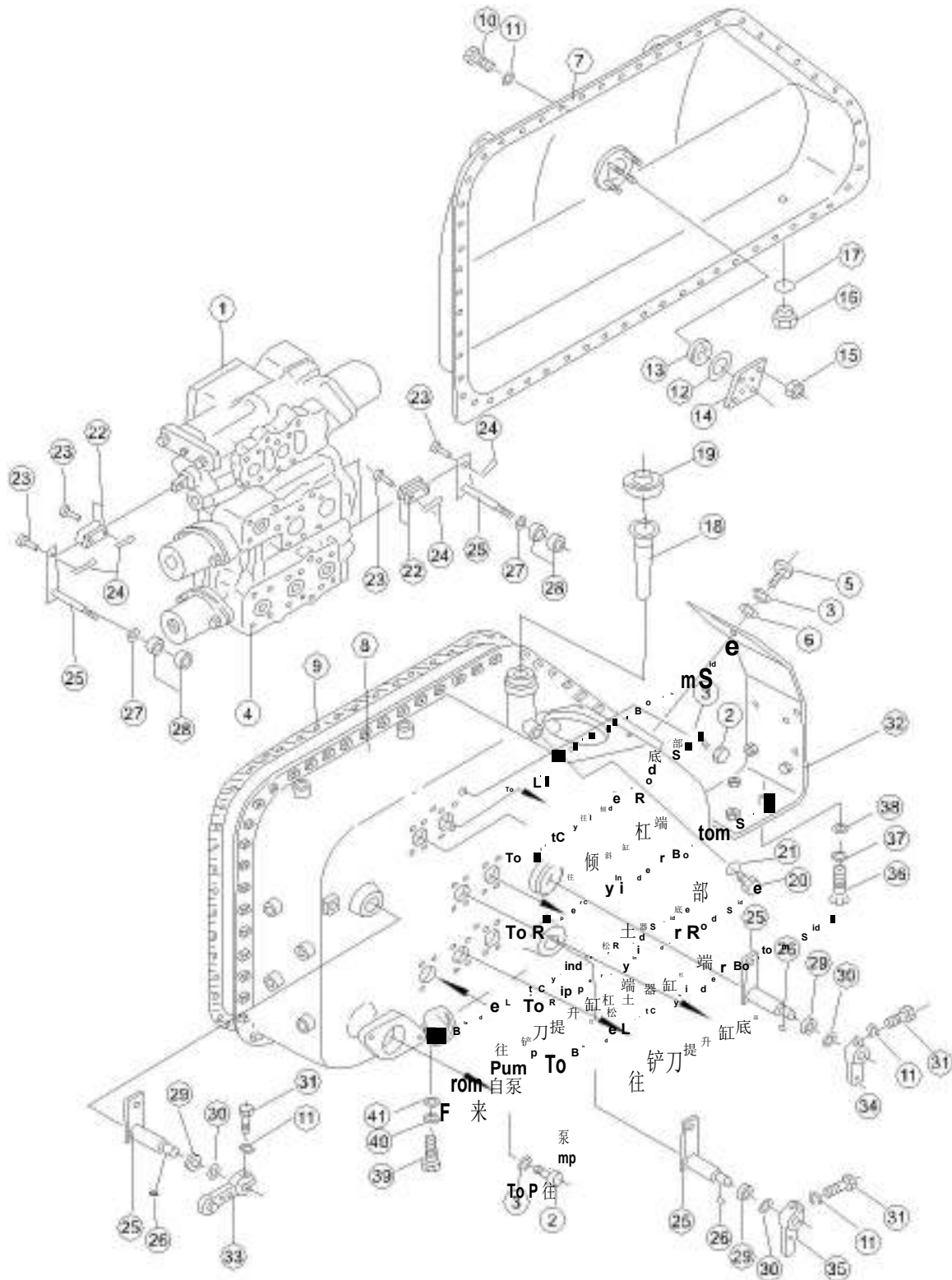

序号 NO.	部件号 PART NO.	零件名称 PART NAME		数量 Q'TY	适用机型 MODEL
0	175-60-29006	工作油箱总成	Oil tank ass'y	1	
1	701-41-11006	倾斜油缸操纵阀总成	Tilt oil cylinder control valve ass'y	1	
2	01010-51230	螺栓 M12*30	Bolt M12*30	7	
3	01602-21236	垫圈 12	Washer 12	11	
4	701-43-24002	工作装置操纵阀总成	Work equipment control valve ass'y	1	
5	01010-51235	螺栓 M12*35	Bolt M12*35	4	
6	01643-31232	垫圈 12	Washer 12	4	
7	175-60-39121	油箱	Oil tank	1	
8	175-60-27119	油箱	Oil tank	1	
9	175-60-27132	垫片	Shim	1	
10	01010-51025	螺栓 M10*25	Bolt M10*25	55	
11	01602-21030	垫圈 10	Washer 10	58	
12	07715-11257	环	Ring	1	
13	07715-00651	蒙	Cover	1	
14	07715-21074	后盖	Rear cover	1	
15	01598-11011	螺母 M10	Nut M10	4	
16	07044-13620	螺塞	Screw plug	1	
17	07002-13634	O 形圈	O-ring	1	
18	07056-10045	过滤网	Filter screen	1	
19	07051-00000	加油口盖	Filler cap	1	
20	701-30-63130	螺塞	Screw plug	1	
21	07002-12034	O 形圈	O-ring	1	
22	141-60-32170	轭	Yoke	6	
23	04205-01028	销轴	Pin shaft	6	
24	04050-03016	开口销	Cotter pin	6	
25	175-60-29140	轴	Shaft	3	
26	04010-10519	半圆键	Woodruff Key	3	
27	175-60-29150	垫圈	Washer	3	
28	GB290-HK2520	冲压外圈滚针轴承	Needle roller bearing	6	
29	154-60-12370	油封	Oil seal	3	
30	01640-22440	垫圈 24	Washer 24	3	
31	01010-51040	螺栓 M10*40	Bolt M10*40	3	



序号 NO.	部件号 PART NO.	零件名称 PART NAME	数量 Q'TY	适用机型 MODEL
32	175-60-27371	托架 Bracket	1	
33	175-60-29120	拉臂 Arm	1	
34	195-60-13120	拉臂 Arm	1	
35	175-60-27310	拉臂 Arm	1	
36	01010-51440	螺栓 M14*40 Bolt M14*40	4	
37	01602-21442	垫圈 14 Washer 14	4	
38	01643-31445	垫圈 14 Washer 14	4	
39	01010-51850	螺栓 M18*50 Bolt M18*50	5	
40	01602-21854	垫圈 18 Washer 18	5	
41	01643-31845	垫圈 18 Washer 18	5	

### 工作油箱 (2/2) HYDRAULIC TANK (2/2)

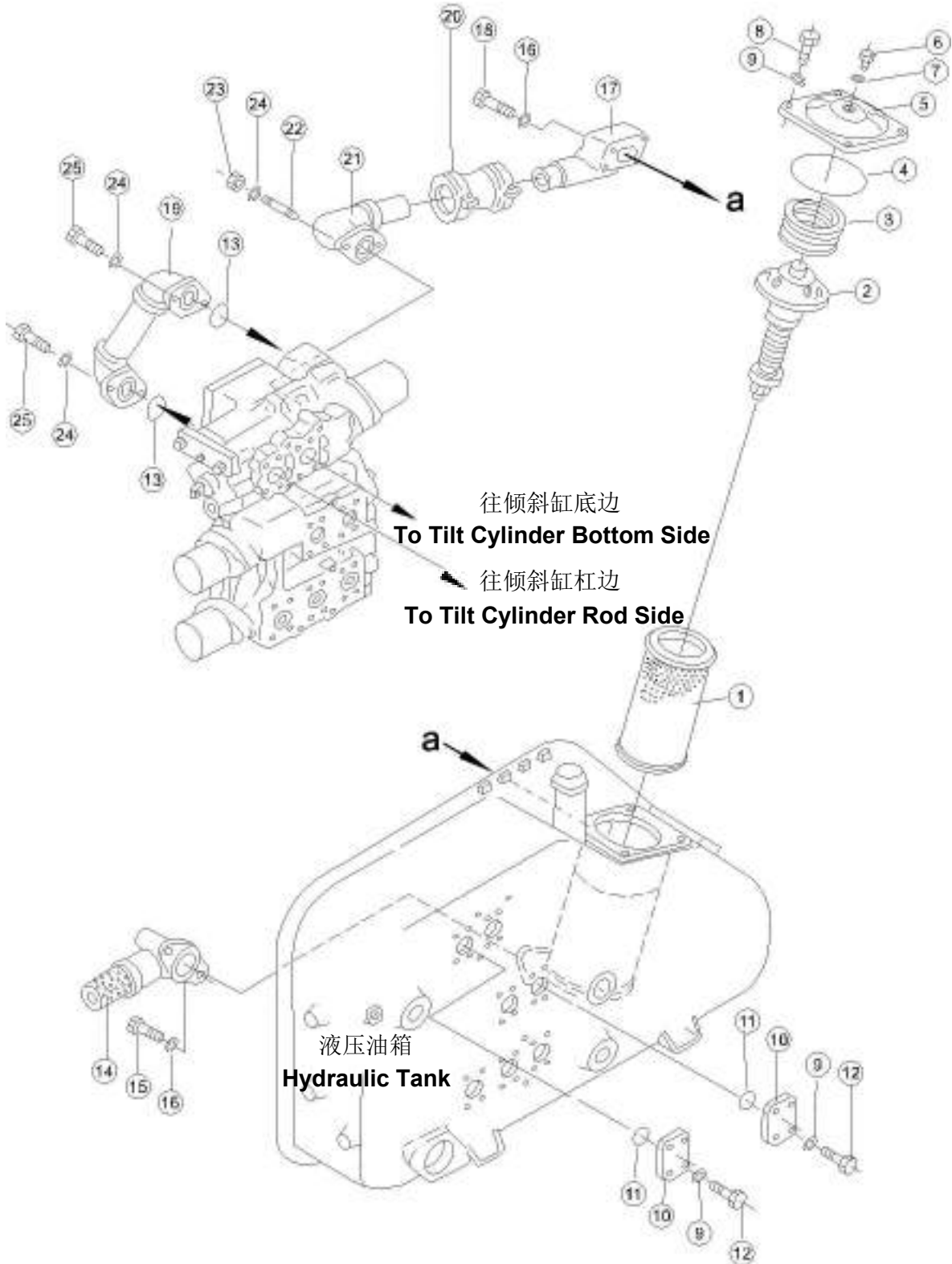

序号 NO.	部件号 PART NO.	零件名称 PART NAME	数量 Q'TY	适用机型 MODEL
0	175-60-29006	工作油箱总成 Oil tank ass'y	1	
1	175-60-27380	滤芯 Filter	1	
2	175-60-27300	阀组件 Valve ass'y	1	
3	175-60-27340	弹簧 Spring	1	
4	07000-15150	O 形圈 O-ring	1	
5	175-60-27171	盖 Cover	1	
6	154-60-12260	螺塞 Screw plug	1	
7	07000-12010	O 形圈 O-ring	1	
8	01010-51235	螺栓 M12*35 Bolt M12*35	4	
9	01602-21236	垫圈 12 Washer 12	20	
10	07378-01460	防尘盖 Cover, Dust	4	
11	07000-13048	O 形圈 O-ring	4	
12	01010-51240	螺栓 M12*40 Bolt M12*40	16	
13	07000-13050	O 形圈 O-ring	2	
14	175-60-29130	缓冲装置 Cushion	1	
15	01010-51230	螺栓 M12*30 Bolt M12*30	2	
16	01643-31232	垫圈 12 Washer 12	4	
17	175-60-27262	弯头 Elbow	1	
18	01010-51275	螺栓 M12*75 Bolt M12*75	2	
19	175-60-27253	管子 Tube	1	
20	07332-01400	联接器 Connector	1	
21	175-60-27272	弯头 Elbow	1	
22	01144-51435	螺柱 Stud	2	
23	01580-01411	螺母 M14 Nut M14	2	
24	01643-31445	垫圈 14 Washer 14	6	
25	01010-51445	螺栓 M14*45 Bolt M14*45	4	

### 铲刀提升与松土器阀 (1/2) BLADE LIFT AND RIPPER CONTROL VALVE (1/2)

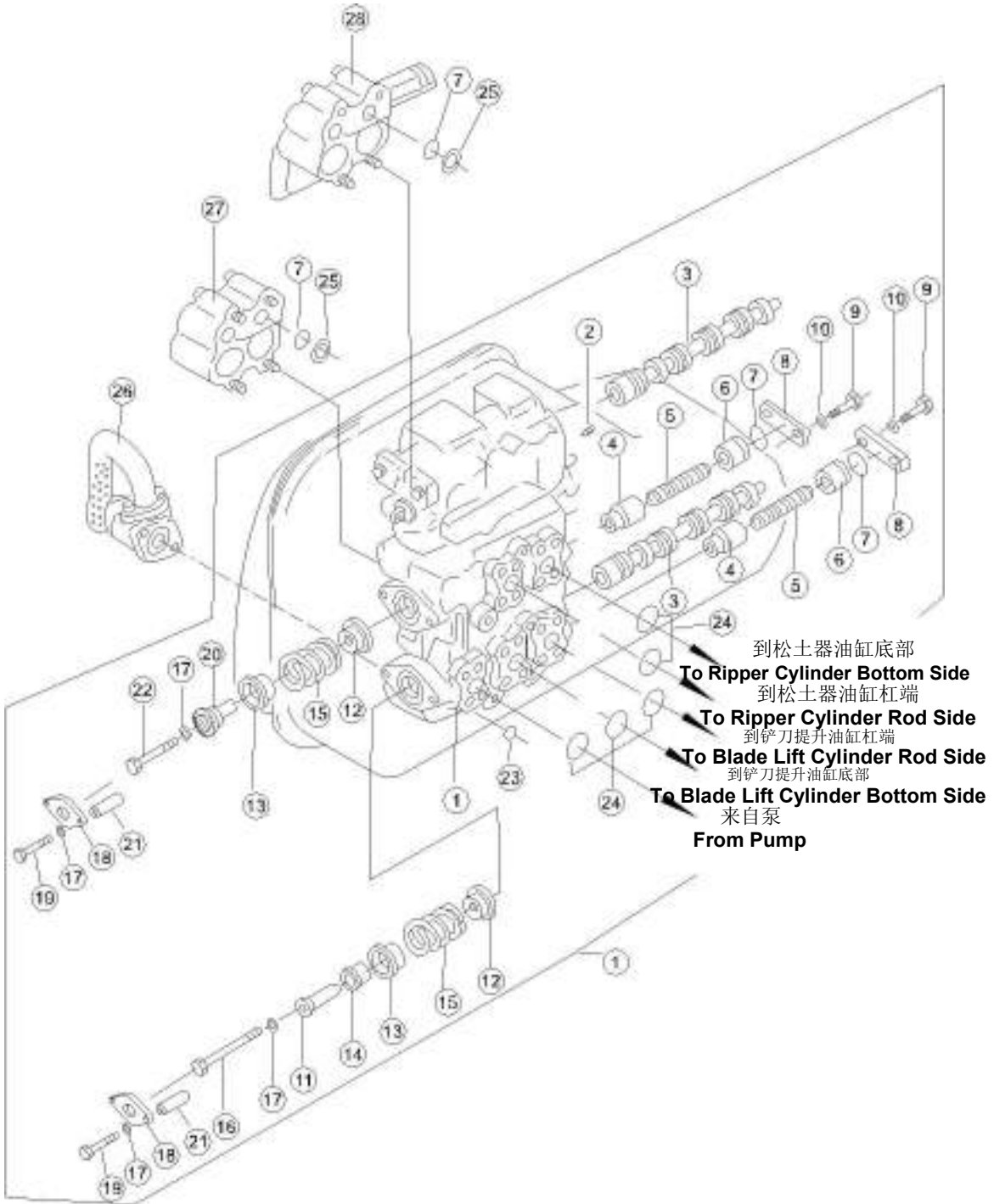

序号 NO.	部件号 PART NO.	零件名称 PART NAME	数量 Q'TY	适用机型 MODEL
0	701-43-24002	工作装置操纵阀总成 Work equipment control valve ass'y	1	
1	701-43-31510	阀体 Valve body	1	
1	701-43-41002	工作装置操纵阀 Work equipment control valve	1	
2	07042-20415	螺塞 Screw plug	2	
3	701-43-31480	阀杆 Valve stem	2	
4	701-43-31420	阀芯 Valve core	2	
5	701-53-31130	弹簧 Spring	2	
6	701-43-33130	座 Seat	2	
7	07000-13035	O 形圈 O-ring	6	
8	701-53-31160	板 Plate	2	
9	01010-51445	螺栓 M14*45 Bolt M14*45	4	
10	01602-21442	垫圈 14 Washer 14	4	
11	701-43-31440	轴套 Sleeve	1	
12	701-43-31181	隔套 Spacer	2	
13	701-43-31191	隔套 Spacer	2	
14	701-43-31211	轴套 Sleeve	1	
15	701-43-31221	弹簧 Spring	2	
16	01010-51285	螺栓 M12*85 Bolt M12*85	1	
17	01602-21236	垫圈 12 Washer 12	6	
18	701-43-31460	板 Plate	2	
19	01011-51215	螺栓 M12*115 Bolt M12*115	4	
20	701-43-31291	轴套 Sleeve	1	
21	701-43-31470	垫管 Tube	4	
22	01010-51290	螺栓 M12*90 Bolt M12*90	1	
23	701-51-31250	O 型圈 O-ring	5	
24	07000-12015	O 形圈 O-ring	25	
25	701-40-61180	衬垫环 Gasket ring	4	
26	701-40-51002	安全阀 Safety valve	1	
27	701-40-61002	补油阀组件 Valve ass'y	1	
28	701-40-62002	松土器安全阀 Ripper safety valve	1	

### 铲刀提升与松土器阀 (2/2) BLADE LIFT AND RIPPER CONTROL VALVE (2/2)

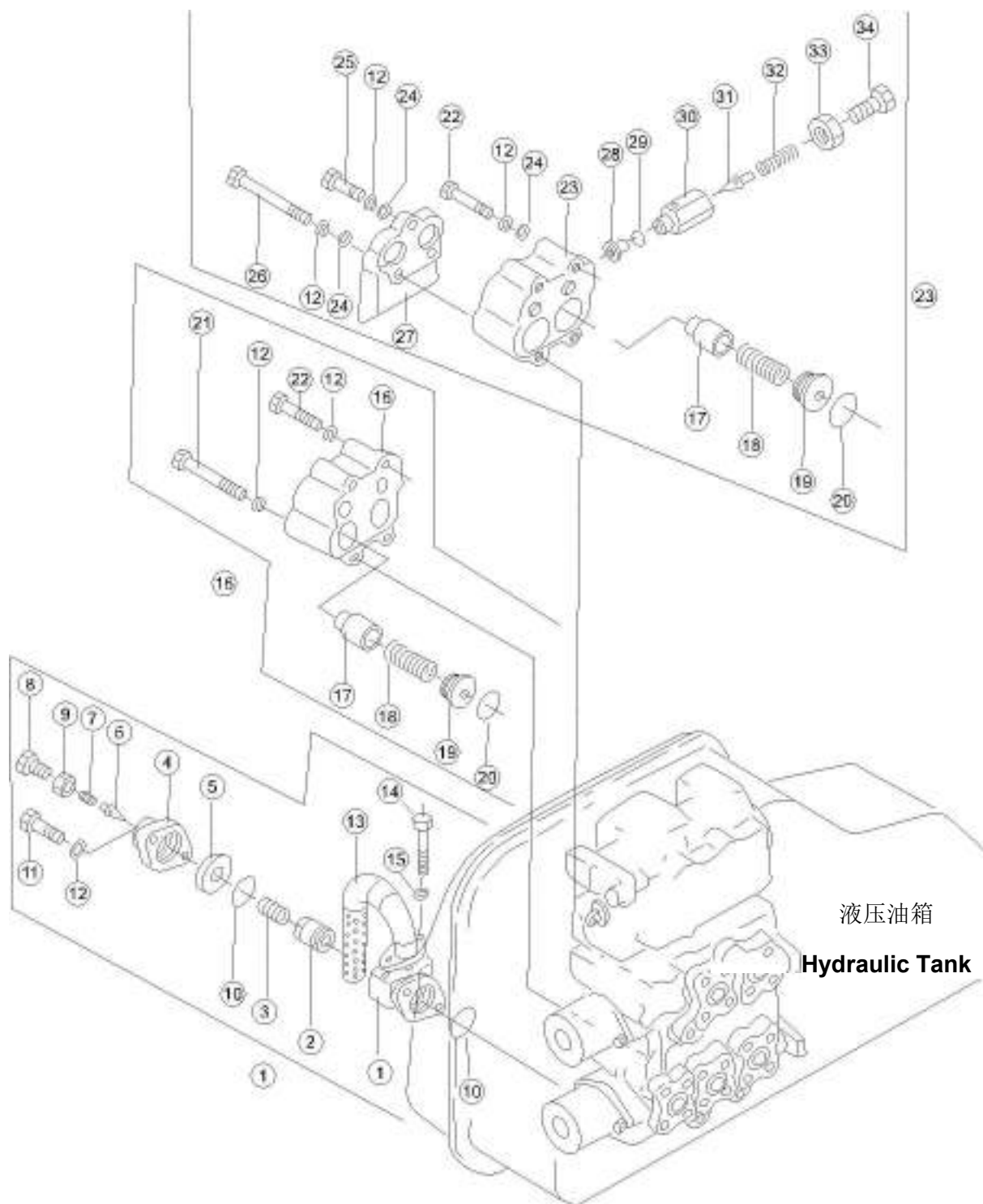

序号 NO.	部件号 PART NO.	零件名称 PART NAME	数量 Q'TY	适用机型 MODEL
0	701-43-24002	工作装置操纵阀总成 Work equipment control valve ass'y	1	
1	701-40-51002	安全阀 Safety valve	1	
1	701-40-51111	阀体 Valve body	1	
2	701-40-51120	阀芯 Valve core	1	
3	701-30-51130	弹簧 Spring	1	
4	701-40-51130	法兰盖 Cover, Flange	1	
5	701-30-51151	阀座 Valve seat	1	
6	701-30-51160	锥阀 Poppet valve	1	
7	701-30-51171	弹簧 Spring	1	
8	701-10-51160	螺塞 Screw plug	1	
9	701-30-51190	螺母 Nut	1	
10	07000-13048	O 形圈 O-ring	2	
11	01011-51405	螺栓 M14*105 Bolt M14*105	2	
12	01602-21442	垫圈 14 Washer 14	11	
13	701-40-51160	缓冲管 Buffer tube	1	
14	01010-51030	螺栓 M10*30 Bolt M10*30	2	
15	01602-21030	垫圈 10 Washer 10	2	
16	701-40-61002	补油阀组件 Valve ass'y	1	
16	701-40-61152	阀体 Valve body	1	
17	701-40-61120	阀 Valve	4	
18	701-50-61131	弹簧 Spring	4	
19	701-40-72120	座 Seat	4	
20	07000-13040	O 形圈 O-ring	4	
21	01011-51420	螺栓 M14*120 Bolt M14*120	2	
22	01010-51495	螺栓 M14*95 Bolt M14*95	4	
23	701-40-62002	松土器安全阀 Ripper safety valve	1	
23	701-40-62162	阀体 Valve body	1	
24	01643-31445	垫圈 14 Washer 14	3	
25	01010-51455	螺栓 M14*55 Bolt M14*55	1	
26	01011-51465	螺栓 M14*165 Bolt M14*165	2	
27	701-40-62171	补油管 Oil supply tube	1	
28	701-30-72122	座 Seat	1	

### 铲刀提升与松土器阀 (2/2) BLADE LIFT AND RIPPER CONTROL VALVE (2/2)

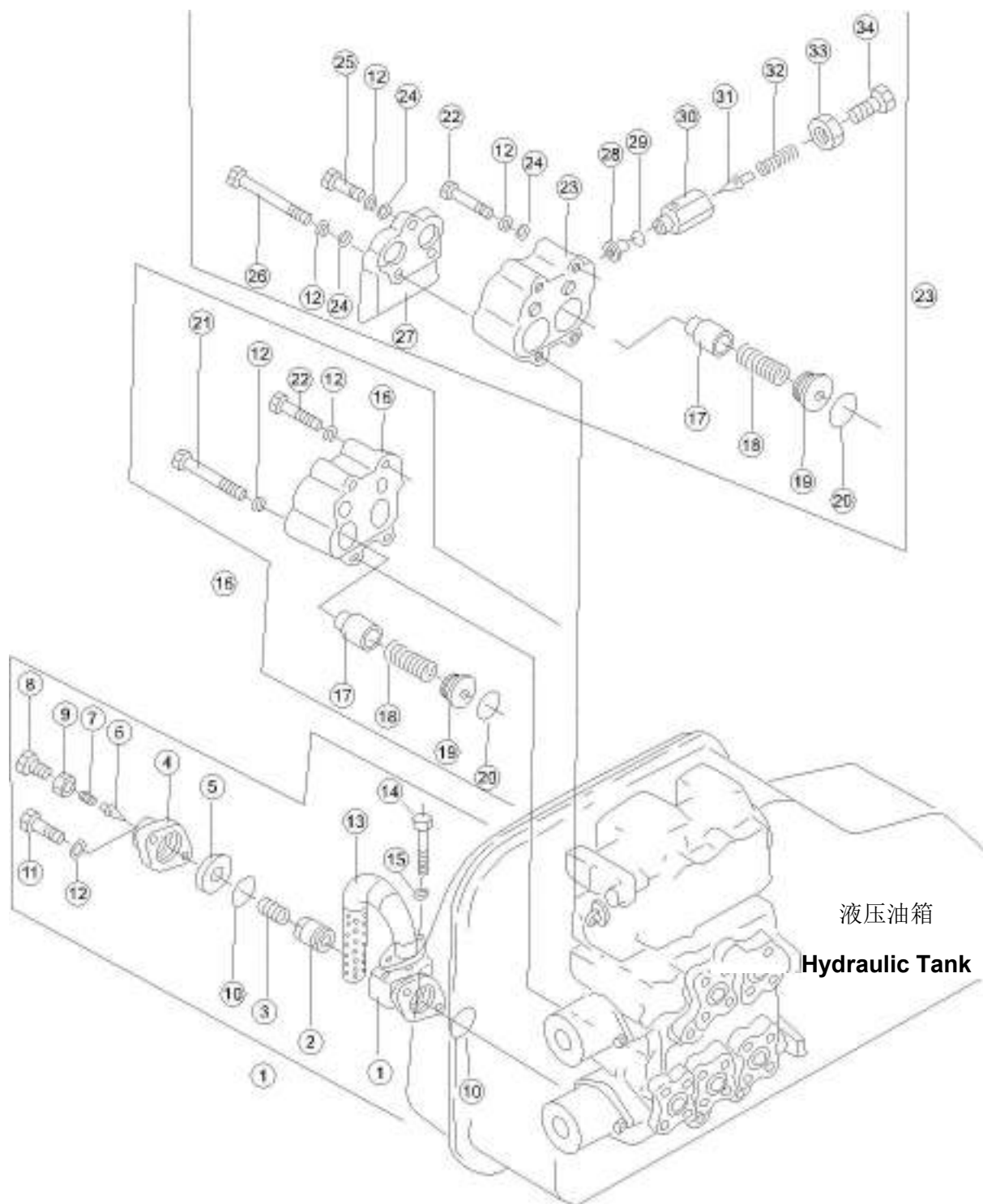

序号 NO.	部件号 PART NO.	零件名称 PART NAME		数量 Q'TY	适用机型 MODEL
29	07002-13034	O 形圈	O-ring	1	
30	701-30-72112	阀体	Valve body	1	
31	701-30-72132	阀芯	Valve core	1	
32	701-30-72140	弹簧	Spring	1	
33	01583-53018	螺母 M30*1.5	Nut M30*1.5	1	
34	701-30-72150	螺塞	Screw plug	1	

### 倾斜油缸操纵阀总成 TILT OIL CYLINDER CONTROL VALVE ASS'Y

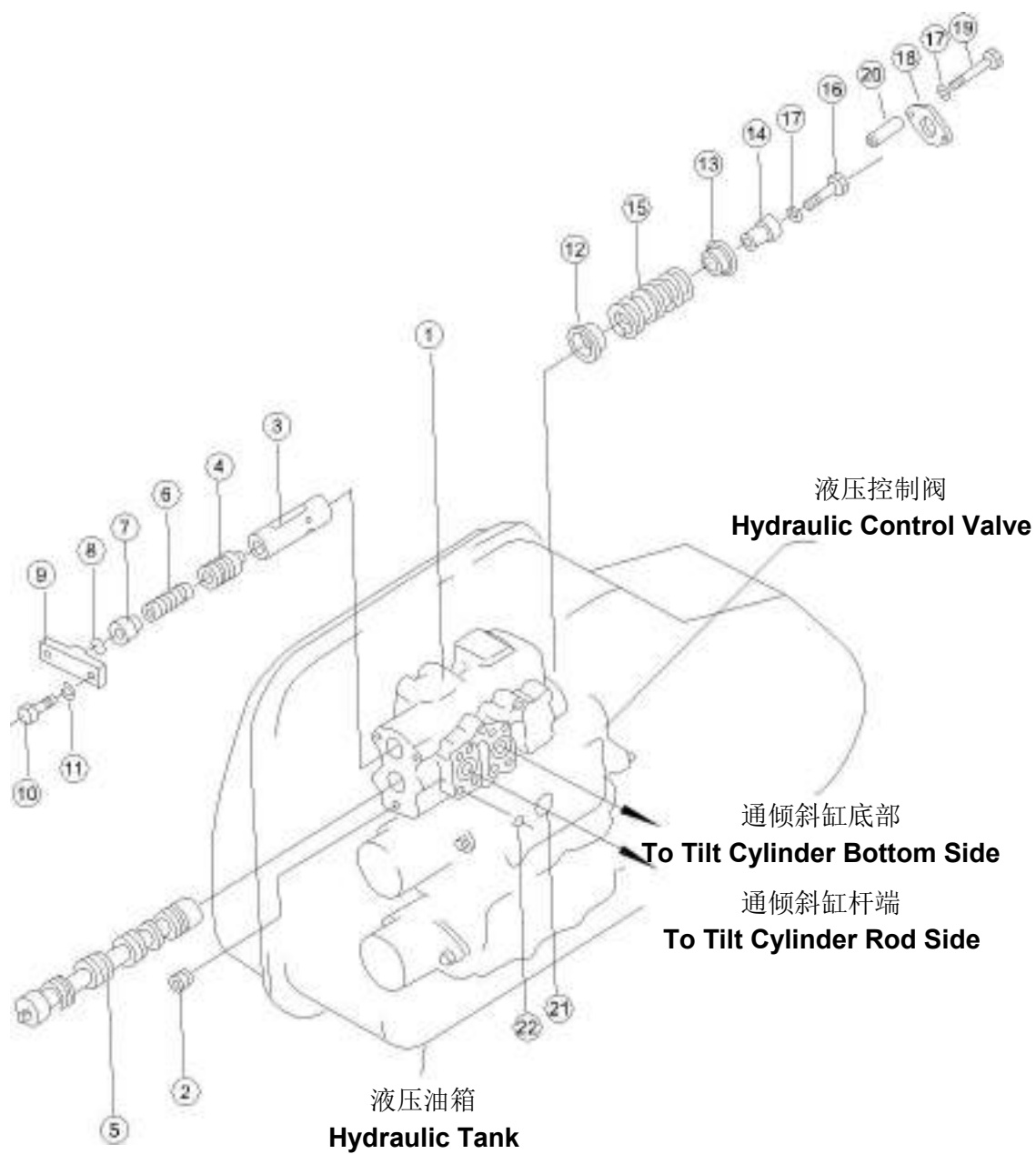

序号 NO.	部件号 PART NO.	零件名称 PART NAME		数量 Q'TY	适用机型 MODEL
1	701-41-31320	阀体	Valve body	1	
2	07042-20415	螺塞	Screw plug	1	
3	701-41-31121	套环	Collar	1	
4	701-41-31130	阀杆	Valve stem	1	
5	701-43-31480	阀杆	Valve stem	1	
6	701-41-31180	弹簧	Spring	1	
7	701-41-31150	座	Seat	1	
8	07000-13028	O 形圈	O-ring	1	
9	701-51-31172	板	Plate	1	
10	01010-51450	螺栓 M14*50	Bolt M14*50	2	
11	01602-21442	垫圈 14	Washer 14	2	
12	701-43-31181	隔套	Spacer	1	
13	701-43-31191	隔套	Spacer	1	
14	701-43-31291	轴套	Sleeve	1	
15	701-43-31221	弹簧	Spring	1	
16	01010-51290	螺栓 M12*90	Bolt M12*90	1	
17	01602-21236	垫圈 12	Washer 12	3	
18	701-43-31460	板	Plate	1	
19	01011-51215	螺栓 M12*115	Bolt M12*115	2	
20	701-43-31470	垫管	Tube	2	
21	701-51-31250	O 型圈	O-ring	2	
22	07000-12015	O 形圈	O-ring	11	

# 工作泵管路总成 HYDRAULIC PIPING ASS'Y

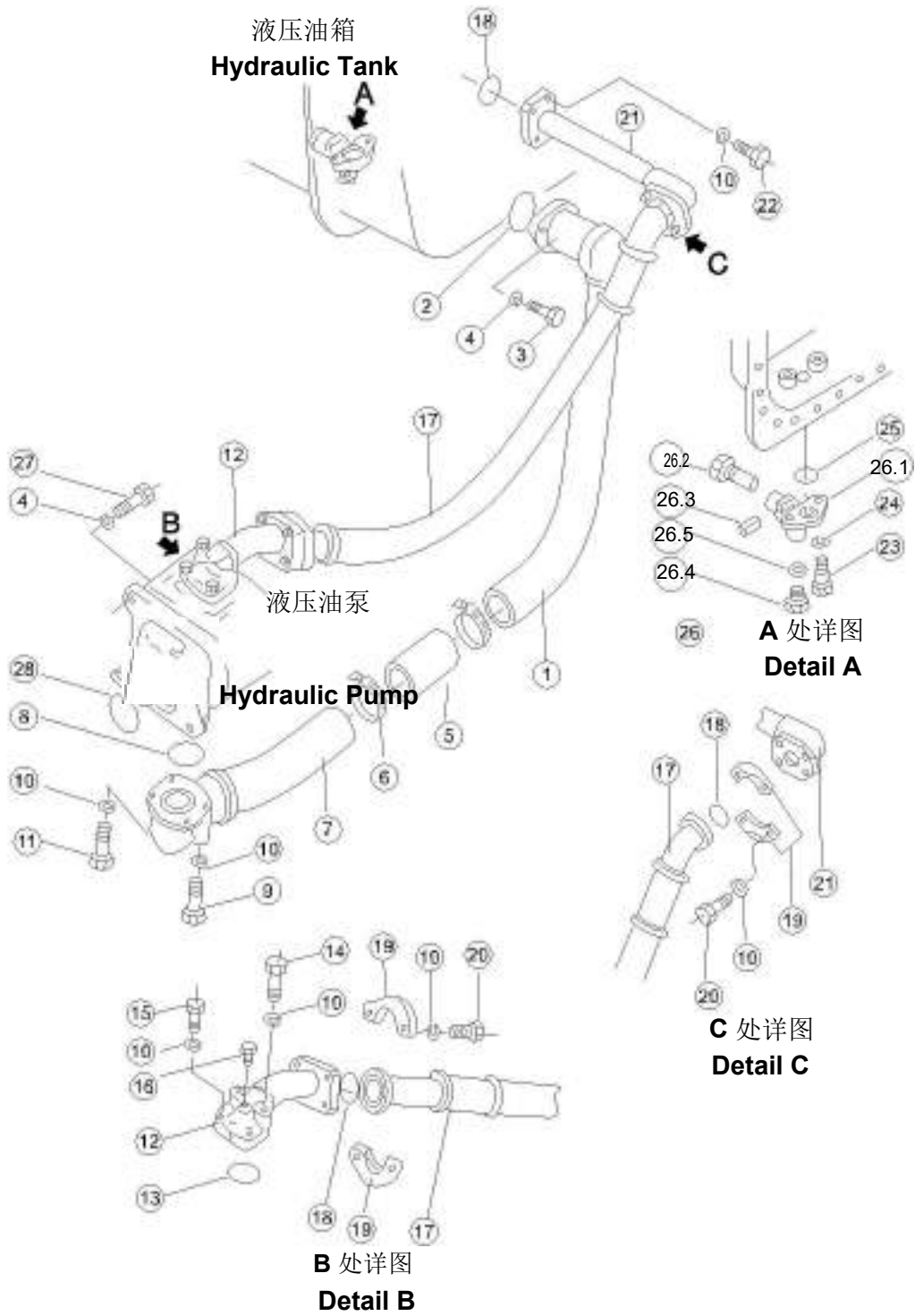

序号 NO.	部件号 PART NO.	零件名称 PART NAME	数量 Q'TY	适用机型 MODEL
1	175-60-26114	管子 Tube	1	
2	07000-12075	O 形圈 O-ring	1	
3	01010-51455	螺栓 M14*55 Bolt M14*55	2	
4	01602-21442	垫圈 14 Washer 14	6	
5	24Y-61-01000	软管 Hose	1	
6	07289-00095	管夹 Clip	4	
7	175-60-26141	管子 Tube	1	
8	07000-12070	O 形圈 O-ring	1	
9	01011-51200	螺栓 M12*100 Bolt M12*100	2	
10	01602-21236	垫圈 12 Washer 12	20	
11	01010-51245	螺栓 M12*45 Bolt M12*45	2	
12	175-60-26162	管 Tube	1	
13	07000-13050	O 形圈 O-ring	1	
14	01010-51285	螺栓 M12*85 Bolt M12*85	2	
15	01010-51255	螺栓 M12*55 Bolt M12*55	2	
16	07042-20108	螺塞 Screw plug	1	
17	07114-01409	软管 Hose	1	
18	07000-13048	O 形圈 O-ring	3	
19	07371-31465	法兰 Flange	4	
20	01010-51240	螺栓 M12*40 Bolt M12*40	8	
21	175-60-26182	管 Tube	1	
22	01010-51250	螺栓 M12*50 Bolt M12*50	4	
23	01010-51025	螺栓 M10*25 Bolt M10*25	2	
24	01602-21030	垫圈 10 Washer 10	2	
25	07000-13025	O 形圈 O-ring	1	
26.3	04025-00532	圆柱销 Cylindrical pin	1	
26	155-60-12500	放油阀总成 Oil drain valve ass'y	1	
26.1	155-60-12510	阀体 Valve body	1	
26.2	155-60-12520	阀 Valve	1	
26.4	07040-12414	螺塞 Screw plug	1	
26.5	07005-02416	密封垫圈 Sealing gasket	1	
27	01010-51445	螺栓 M14*45 Bolt M14*45	4	
28	07000-13092	O 形圈 O-ring	1	

### 铲刀提升管路 (1/2) BLADE LIFT PIPING (1/2)

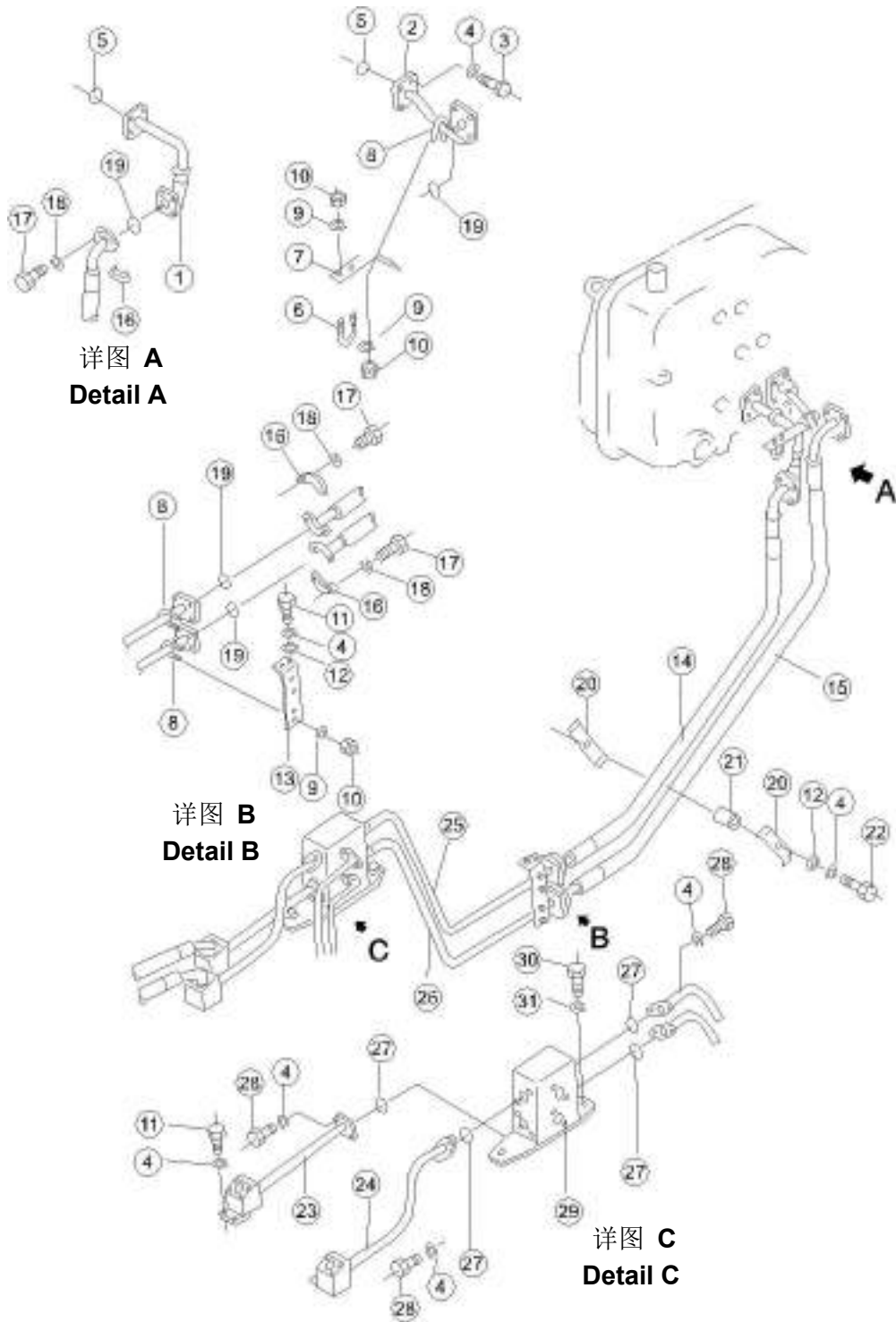

序号 NO.	部件号 PART NO.	零件名称 PART NAME	数量 Q'TY	适用机型 MODEL
1	175-61-14451	管子 Tube	1	
2	175-61-14463	管子 Tube	1	
3	01010-51245	螺栓 M12*45 Bolt M12*45	8	
4	01602-21236	垫圈 12 Washer 12	23	
5	07000-13048	O 形圈 O-ring	2	
6	07283-24346	管夹 Clip	1	
7	175-61-17220	板 Plate	1	
8	07283-23442	管夹 Clip	3	
9	01643-31032	垫圈 10 Washer 10	8	
10	01599-01011	螺母 M10*1.25 Nut M10*1.25	8	
11	01010-51235	螺栓 M12*35 Bolt M12*35	6	
12	01643-31232	垫圈 12 Washer 12	3	
13	175-61-C2130	板 Plate	1	
14	07118-01214	软管 Hose	1	
15	07118-01216	软管 Hose	1	
16	07371-31255	法兰 Flange	8	
17	01010-51035	螺栓 M10*35 Bolt M10*35	16	
18	01602-21030	垫圈 10 Washer 10	16	
19	07000-13038	O 形圈 O-ring	4	
20	175-61-17230	夹子 Clamp	2	
21	175-61-17240	套管 Sleeve	1	
22	01010-51290	螺栓 M12*90 Bolt M12*90	1	
23	175-61-C2240	管子 Tube	1	
24	175-61-C2220	管子 Tube	1	
25	175-61-C2110	管子 Tube	1	
26	175-61-C2120	管子 Tube	1	
27	07000-13035	O 形圈 O-ring	4	
28	01010-51240	螺栓 M12*40 Bolt M12*40	8	
29	175-61-C2140	板 Plate	1	
30	01010-51640	螺栓 M16*40 Bolt M16*40	2	
31	01602-21648	垫圈 16 Washer 16	2	

### 铲刀提升管路 (2/2) BLADE LIFT PIPING (2/2)

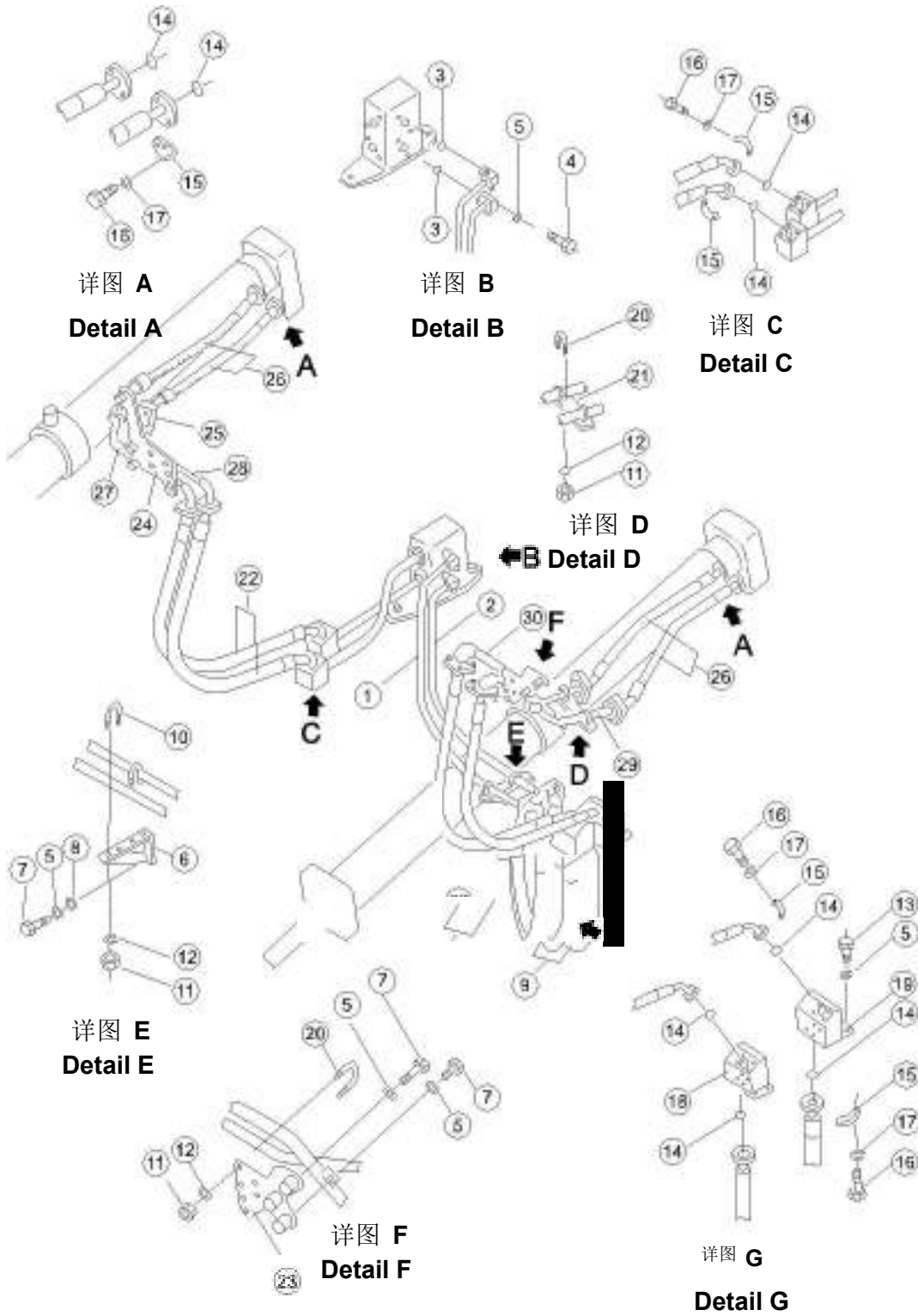

序号 NO.	部件号 PART NO.	零件名称 PART NAME	数量 Q'TY	适用机型 MODEL
1	175-61-C2150	管子 Tube	1	
2	175-61-C2160	管子 Tube	1	
3	07000-13035	O 形圈 O-ring	2	
4	01010-51270	螺栓 M12*70 Bolt M12*70	4	
5	01602-21236	垫圈 12 Washer 12	16	
6	175-61-C2170	托架 Bracket	1	
7	01010-51255	螺栓 M12*55 Bolt M12*55	8	
8	01643-31232	垫圈 12 Washer 12	2	
9	07114-01009	软管 Hose	2	
10	07283-23442	管夹 Clip	2	
11	01599-01011	螺母 M10*1.25 Nut M10*1.25	20	
12	01643-31032	垫圈 10 Washer 10	20	
13	01010-51235	螺栓 M12*35 Bolt M12*35	4	
14	07000-13032	O 形圈 O-ring	20	
15	07371-31049	法兰 Flange	40	
16	01010-51035	螺栓 M10*35 Bolt M10*35	80	
17	01602-21030	垫圈 10 Washer 10	80	
18	175-61-C2180	杆 Lever	1	
19	175-61-C2190	法兰块 Flange	1	
20	07283-23450	管夹 Clip	8	
21	175-61-18390	板 Plate	1	
22	07114-01013	软管 Hose	4	
23	175-61-18330	左板 Plate (L.H.)	1	
24	175-61-18380	右板 Plate (R.H.)	1	
25	175-61-18290	右板 Plate (R.H.)	1	
26	07114-01006	软管 Hose	4	
27	175-61-18340	管子 Tube	1	
28	175-61-18350	管子 Tube	1	
29	175-61-18360	管子 Tube	1	
30	175-61-18370	管子 Tube	1	

# 铲刀提升油缸 BLADE LIFT CYLINDER

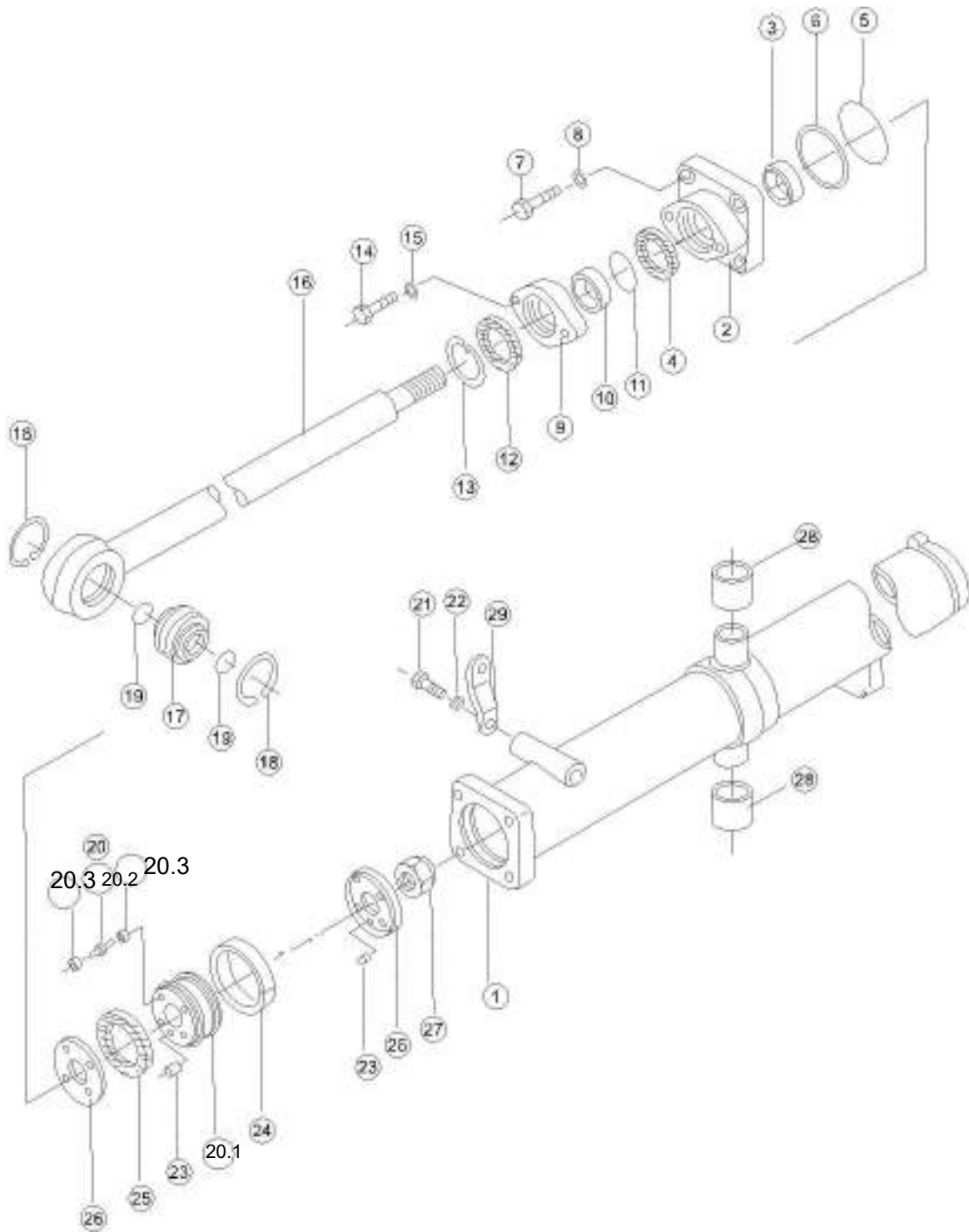

序号 NO.	部件号 PART NO.	零件名称 PART NAME	数量 Q'TY	适用机型 MODEL
0	171-62-01000	提升油缸总成 (左)	1	
0	171-62-02000	提升油缸总成 (右)	1	
1	171-62-01400	缸体	1	
2	175-63-13131	油缸头	1	
3	07177-07530	衬套	1	
4	707-51-75110	密封圈	1	
5	07000-12135	O-型圈	1	
6	07146-02136	保护圈	1	
7	01010-52470	螺栓 M24*70	4	
8	01602-22472	垫圈 24	4	
9	175-63-13630	密封盖	1	
10	07177-07515	衬套	1	
11	07000-13095	O形圈	1	
12	144-63-94170	防尘圈	1	
13	07179-00097	弹性挡环	1	
14	01010-51655	螺栓 M16*55	2	
15	01602-21648	垫圈 16	2	
16	175-63-13120	活塞杆	1	
17	07137-05008	向心关节轴承	1	
18	04065-01110	挡圈	2	
19	07000-13050	O形圈	2	
20	175-63-92662	活塞	1	
21	01010-51245	螺栓 M12*45	1	
22	01643-31232	垫圈 12	1	
23	04020-00616	圆柱销	2	
24	07155-01435	修整圈	1	
25	04059-01020	铁丝	1	
26	175-63-12352	挡圈	2	
27	171-62-01001	螺母	1	
28	175-63-12540	衬套	2	
29	175-63-12370	板	1	

# 快降阀 QUICK DROP VALVE

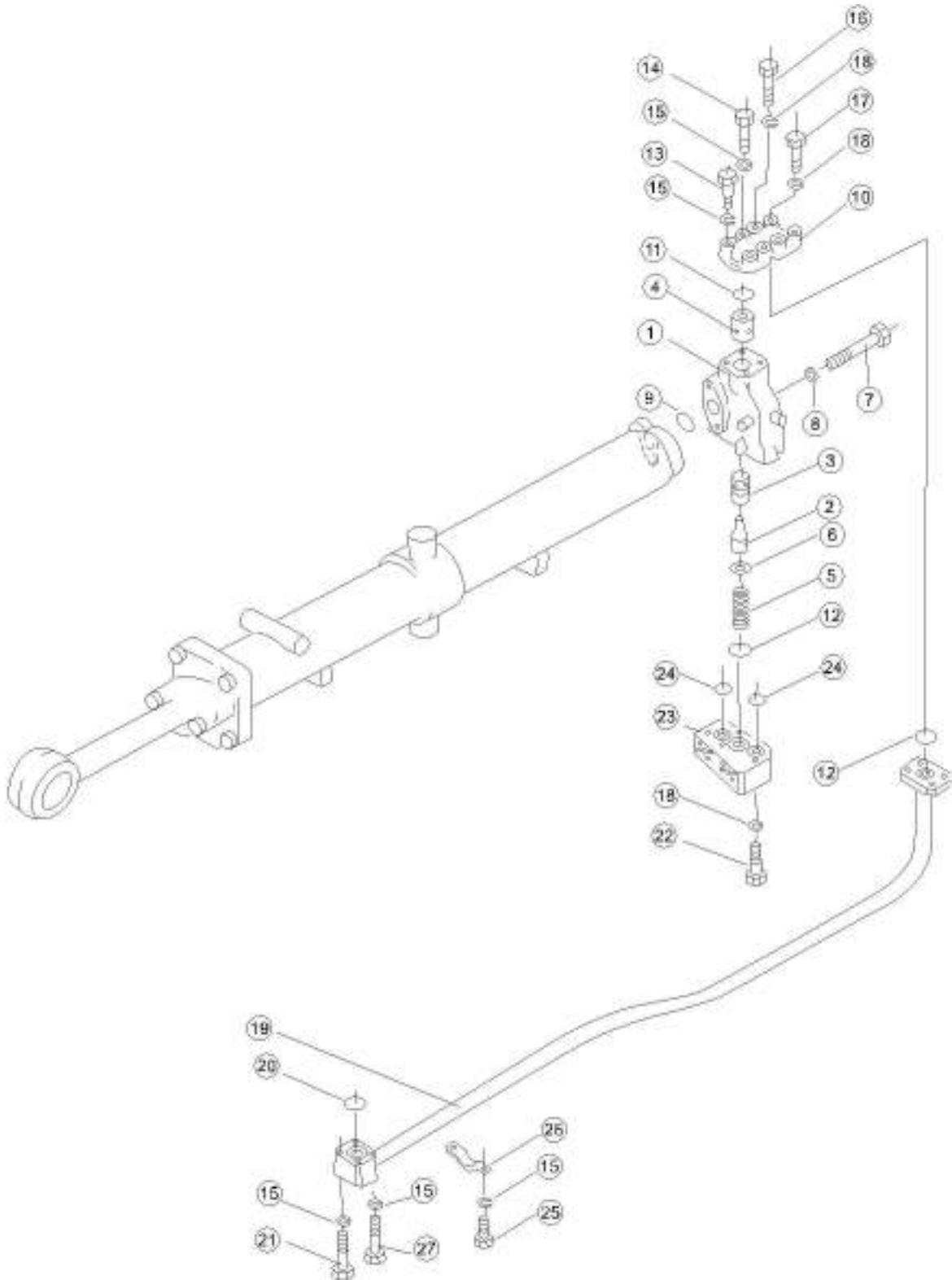

序号 NO.	部件号 PART NO.	零件名称 PART NAME	数量 Q'TY	适用机型 MODEL
0	175-63-13300	铲刀升降油缸总成 ( 左 ) Blade lift oil cylinder ass'y (L.H.)	1	
0	175-63-13400	铲刀升降油缸总成 ( 右 ) Blade lift oil cylinder ass'y (R.H.)	1	
0	195-63-14001	阀总成 Valve ass'y	1	
1	195-63-14111	阀体 Valve body	1	
2	195-63-14140	阀 Valve	1	
3	195-63-14150	阀 Valve	1	
4	195-63-14152	环 Ring	1	
5	195-63-14180	弹簧 Spring	1	
6	01642-21216	垫圈 12 Washer 12	1	
7	01011-51615	螺栓 M16*115 Bolt M16*115	2	
8	01602-21648	垫圈 16 Washer 16	2	
9	07000-12055	O 形圈 O-ring	1	
10	195-63-14130	弯头 Elbow	1	
11	07000-13048	O 形圈 O-ring	1	
12	07000-13045	O 形圈 O-ring	2	
13	01010-51065	螺栓 M10*65 Bolt M10*65	2	
14	01010-51075	螺栓 M10*75 Bolt M10*75	2	
15	01602-21030	垫圈 10 Washer 10	10	
16	01010-51280	螺栓 M12*80 Bolt M12*80	2	
17	01010-51270	螺栓 M12*70 Bolt M12*70	2	
18	01602-21236	垫圈 12 Washer 12	9	
19	175-63-13461	管 ( 左 ) Tube (L.H.)	1	
19	175-63-13471	管 ( 右 ) Tube (R.H.)	1	
20	07000-13035	O 形圈 O-ring	1	
21	01010-51085	螺栓 M10*85 Bolt M10*85	4	
22	01010-51275	螺栓 M12*75 Bolt M12*75	5	
23	175-63-13562	块 Block	1	
23	175-63-13572	块 Block	1	
24	07000-13038	O 形圈 O-ring	2	
25	01010-51020	螺栓 M10*20 Bolt M10*20	2	
26	07282-13411	管夹 Clip	1	
27	01010-51055	螺栓 M10*55 Bolt M10*55	2	

### 倾斜管路 ( 主机以内 ) TILT PIPING (WITHIN THE MAIN SYSTEM)

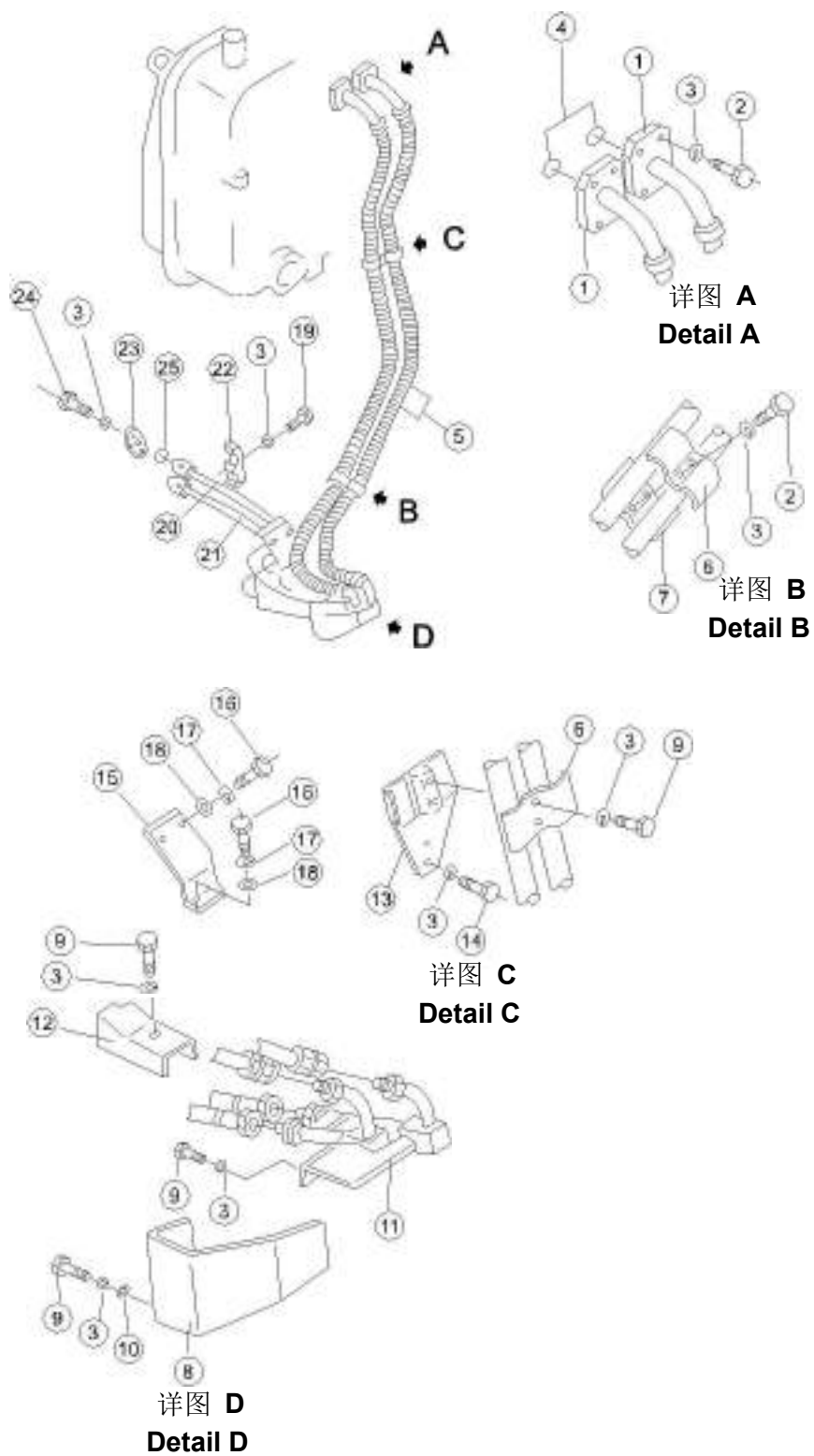

序号 NO.	部件号 PART NO.	零件名称 PART NAME	数量 Q'TY	适用机型 MODEL
1	175-914-4111	管子 Tube	2	
2	01010-51250	螺栓 M12*50 Bolt M12*50	10	
3	01602-21236	垫圈 12 Washer 12	25	
4	07000-13048	O 形圈 O-ring	2	
5	07109-20517	软管 Hose	2	
6	175-71-31370	夹子 Clamp	2	
7	175-914-4260	夹子 Clamp	1	
8	175-61-18162	托架 Bracket	1	
9	01010-51230	螺栓 M12*30 Bolt M12*30	8	
10	01643-31232	垫圈 12 Washer 12	2	
11	175-61-18112	管子 Tube	1	
12	175-61-18120	防护罩 Guard	1	
13	175-61-18210	托架 Bracket	1	
14	01010-51235	螺栓 M12*35 Bolt M12*35	2	
15	175-61-18221	防护罩 Guard	1	
16	01010-51435	螺栓 M14*35 Bolt M14*35	3	
17	01602-21442	垫圈 14 Washer 14	3	
18	01643-31445	垫圈 14 Washer 14	3	
19	01010-51260	螺栓 M12*60 Bolt M12*60	1	
20	175-61-18132	管子 Tube	1	
21	175-61-18142	管子 Tube	1	
22	175-61-18410	管夹 Clip	1	
23	175-61-18180	法兰 Flange	2	
24	01010-51240	螺栓 M12*40 Bolt M12*40	4	
25	07000-13022	O 形圈 O-ring	2	

### 倾斜管路 ( 主机以外 ) TILT PIPING (OUTSIDE THE MAIN SYSTEM)

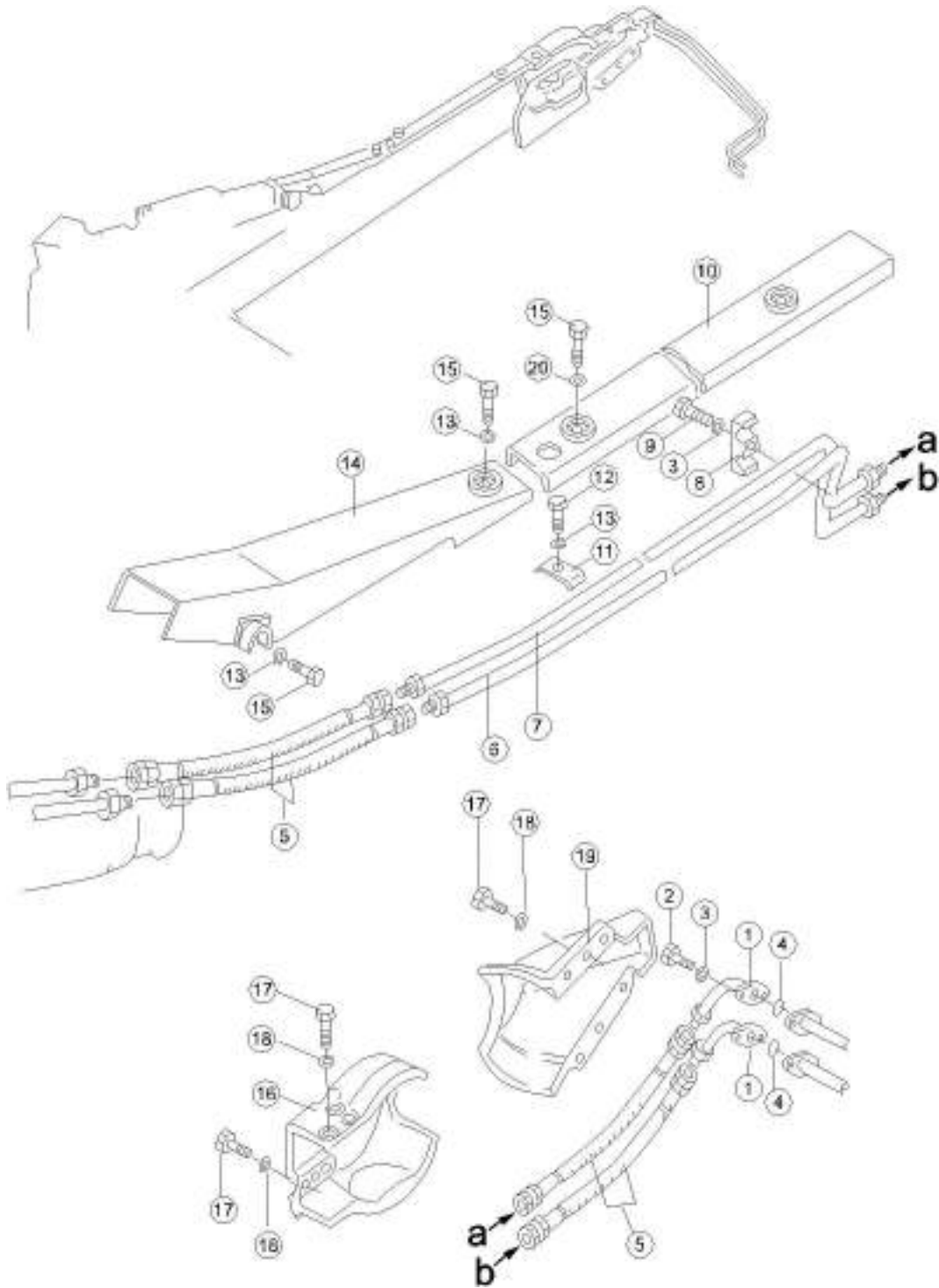

序号 NO.	部件号 PART NO.	零件名称 PART NAME	数量 Q'TY	适用机型 MODEL
1	175-71-31430	管 Tube	2	
2	01010-51240	螺栓 M12*40 Bolt M12*40	4	
3	01602-21236	垫圈 12 Washer 12	5	
4	07000-13022	O 形圈 O-ring	2	
5	07113-00506	软管 Hose	4	
6	175-71-31441	管子 Tube	1	
7	175-71-31451	管子 Tube	1	
8	175-61-18410	管夹 Clip	1	
9	01010-51255	螺栓 M12*55 Bolt M12*55	1	
10	175-71-31342	罩 Cover	1	
11	154-71-31410	夹子 Clamp	1	
12	01010-51425	螺栓 M14*25 Bolt M14*25	1	
13	01643-31445	垫圈 14 Washer 14	4	
14	175-71-31353	罩 Cover	1	
15	01010-51435	螺栓 M14*35 Bolt M14*35	5	
16	175-71-31321	罩 Cover	1	
17	01010-52050	螺栓 M20*50 Bolt M20*50	13	
18	01643-32060	垫圈 20 Washer 20	13	
19	175-71-31331	罩 Cover	1	
20	195-71-32220	垫圈 Washer	2	

### 倾斜油缸总成 TILT OIL CYLINDER ASS'Y

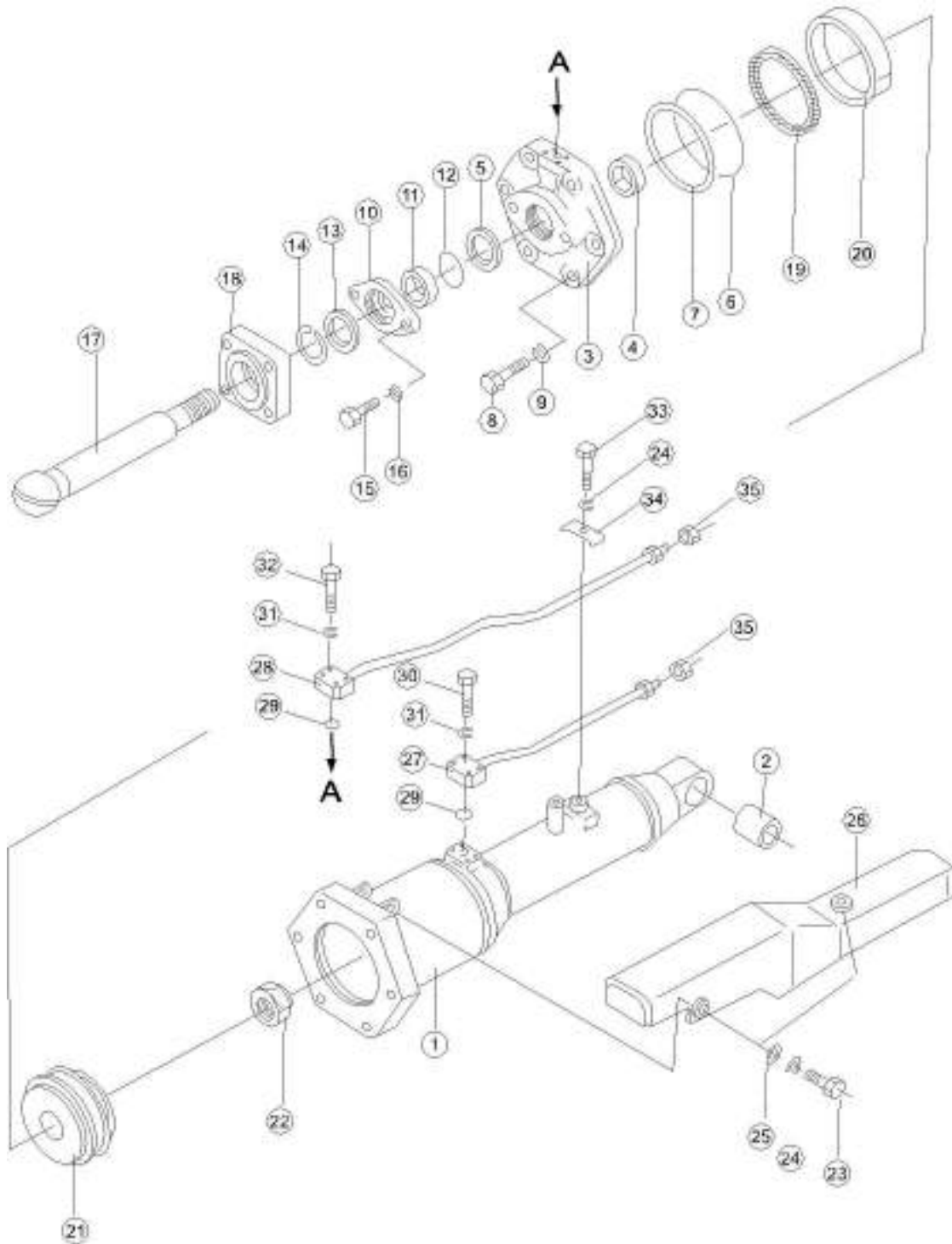

序号 NO.	部件号 PART NO.	零件名称 PART NAME	数量 Q'TY	适用机型 MODEL
1	175-63-52542	缸体 Cylinder body	1	
2	195-63-52160	衬套 Bushing	1	
3	195-63-42133	油缸头 Oil cylinder head	1	
4	07177-09035	衬套 Bushing	1	
5	707-51-90110	密封圈 Seal ring	1	
6	07000-15220	O 形圈 O-ring	1	
7	07001-05220	保护圈 Guard ring	1	
8	01011-53000	螺栓 M30*3*100 Bolt M30*3*100	6	
9	01601-23075	垫圈 30 Washer 30	6	
10	195-63-52470	密封盖 Seal cap	1	
11	07177-09020	衬套 Bushing	1	
12	07000-13110	O 形圈 O-ring	1	
13	195-63-94170	防尘圈 Ring, Dust	1	
14	07179-00113	弹性挡环 Retainer	1	
15	01010-51865	螺栓 M18*65 Bolt M18*65	2	
16	01602-21854	垫圈 18 Washer 18	2	
17	175-63-52422	活塞杆 Piston rod	1	
18	175-71-11211	盖 Cover	1	
19	707-44-22080	活塞密封圈 Piston ring	1	
20	07155-02250	修整圈 Trim ring	1	
21	707-36-22550	活塞 Piston	1	
22	07165-16870	螺母 Nut	1	
23	01010-51440	螺栓 M14*40 Bolt M14*40	3	
24	01602-21442	垫圈 14 Washer 14	4	
25	01643-31445	垫圈 14 Washer 14	3	
26	175-63-52572	罩 Cover	1	
27	175-63-52552	油管 Oil tube	1	
28	175-63-52562	管子 Tube	1	
29	07000-13035	O 形圈 O-ring	2	
30	01010-51050	螺栓 M10*50 Bolt M10*50	4	
31	01602-21030	垫圈 10 Washer 10	8	
32	01010-51030	螺栓 M10*30 Bolt M10*30	4	
33	01010-51420	螺栓 M14*20 Bolt M14*20	1	
34	195-63-52871	弓形夹 Bow-shaped clip	1	
35	195-63-52990	螺塞 Screw plug	2	

# 松土器管路 RIPPER PIPING

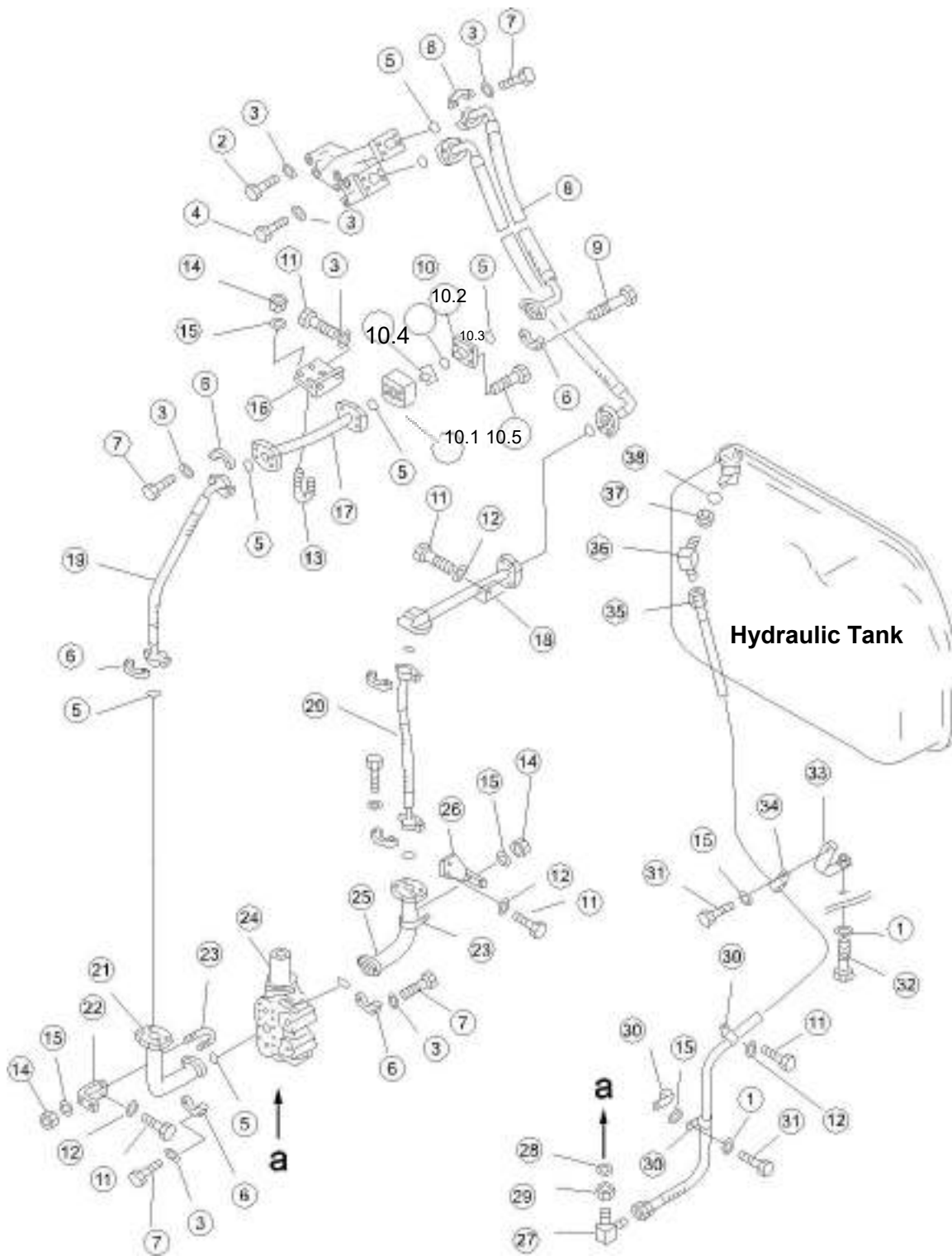

序号 NO.	部件号 PART NO.	零件名称 PART NAME		数量 Q'TY	适用机型 MODEL
1	01602-21030	垫圈 10	Washer 10	4	
2	01010-51270	螺栓 M12*70	Bolt M12*70	3	
3	01602-21236	垫圈 12	Washer 12	49	
4	01011-51205	螺栓 M12*105	Bolt M12*105	4	
5	07000-13048	O 形圈	O-ring	11	
6	07371-31465	法兰	Flange	20	
7	01010-51240	螺栓 M12*40	Bolt M12*40	38	
8	175-78-62480	软管	Hose	2	
9	01010-51295	螺栓 M12*95	Bolt M12*95	4	
10.30	07000-12055	O 形圈	O-ring	1	
10.10	01010-51290	螺栓 M12*90	Bolt M12*90	4	
10	175-78-62101	阀总成	Valve ass'y	1	
10.20	175-78-62140	法兰	Flange	1	
10.40	175-78-62151	阀	Valve	1	
11	01010-51235	螺栓 M12*35	Bolt M12*35	8	
10.50	175-78-62260	法兰	Flange	1	
12	01643-31232	垫圈 12	Washer 12	6	
13	07283-24354	管夹	Clip	2	
14	01599-01011	螺母 M10*1.25	Nut M10*1.25	8	
15	01643-31032	垫圈 10	Washer 10	10	
16	175-78-62123	托架	Bracket	1	
17	175-78-62173	管	Tube	1	
18	175-78-62163	管	Tube	1	
19	07114-01407	软管	Hose	1	
20	07114-01406	软管	Hose	1	
21	175-78-63110	管	Tube	1	
22	175-78-63230	托板	Plate	1	
23	07283-24346	管夹	Clip	2	
24	700-61-13006	DC 和 PC 阀总成	DC & PC valve ass'y	1	
25	175-78-63250	管	Tube	1	
26	175-78-63241	托板	Plate	1	
27	175-78-32170	弯管接头	Elbow	1	

# 松土器管路 RIPPER PIPING

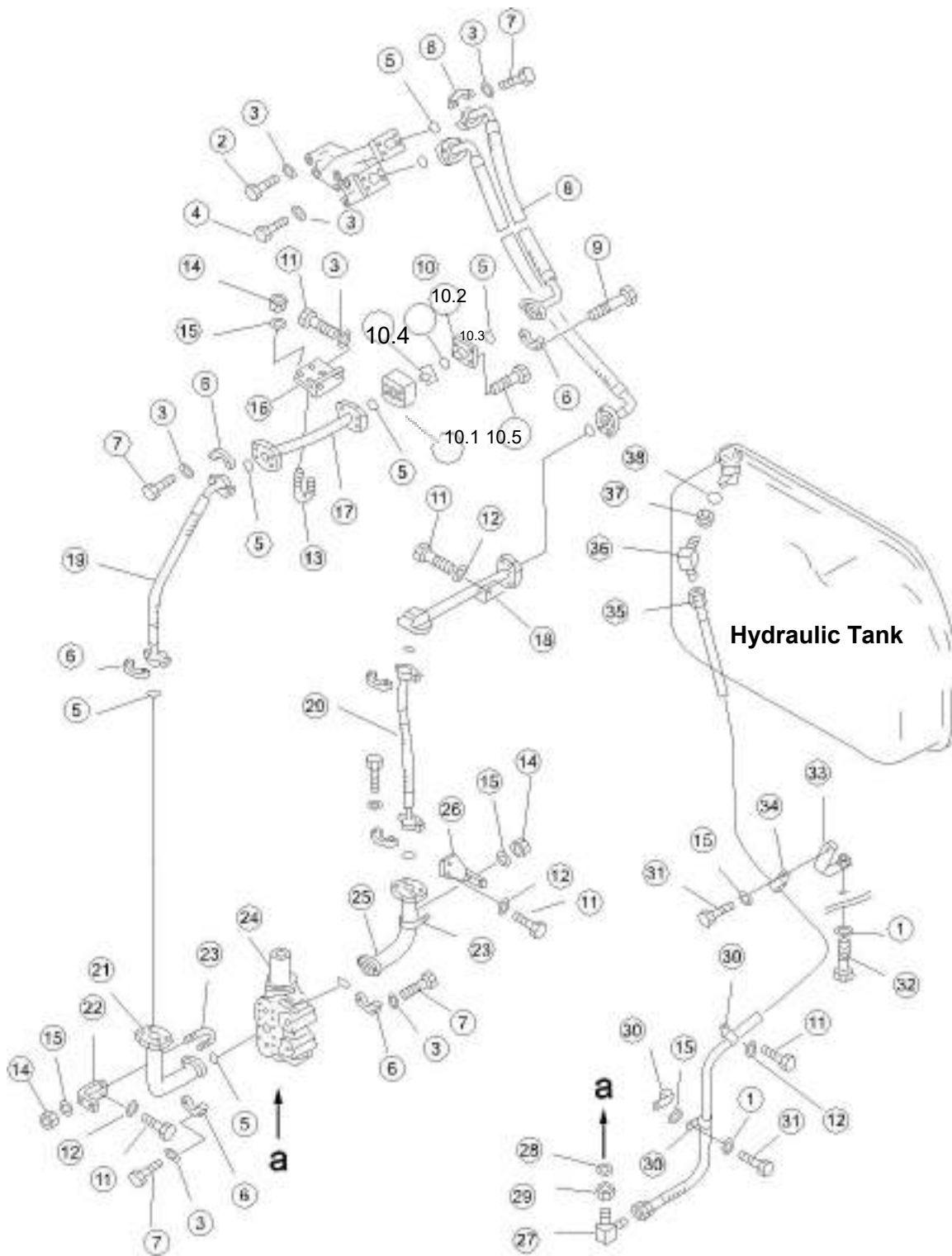

序号 NO.	部件号 PART NO.	零件名称 PART NAME		数量 Q'TY	适用机型 MODEL
28	07002-11623	O 形圈	O-ring	1	
29	01583-51610	螺母 M16*1.5	Nut M16*1.5	1	
30	195-78-22471	夹	Clip	2	
31	01010-51025	螺栓 M10*25	Bolt M10*25	2	
32	01010-51030	螺栓 M10*30	Bolt M10*30	2	
33	175-78-65120	托架	Bracket	1	
34	195-79-12181	夹	Clip	2	
35	07113-00320	软管	Hose	1	
36	07234-10315	接头体	Body, Joint	1	
37	07239-12009	螺母	Nut	1	
38	07002-02034	O 形圈	O-ring	1	

## 松土器油缸管路 RIPPER CYLINDER PIPING

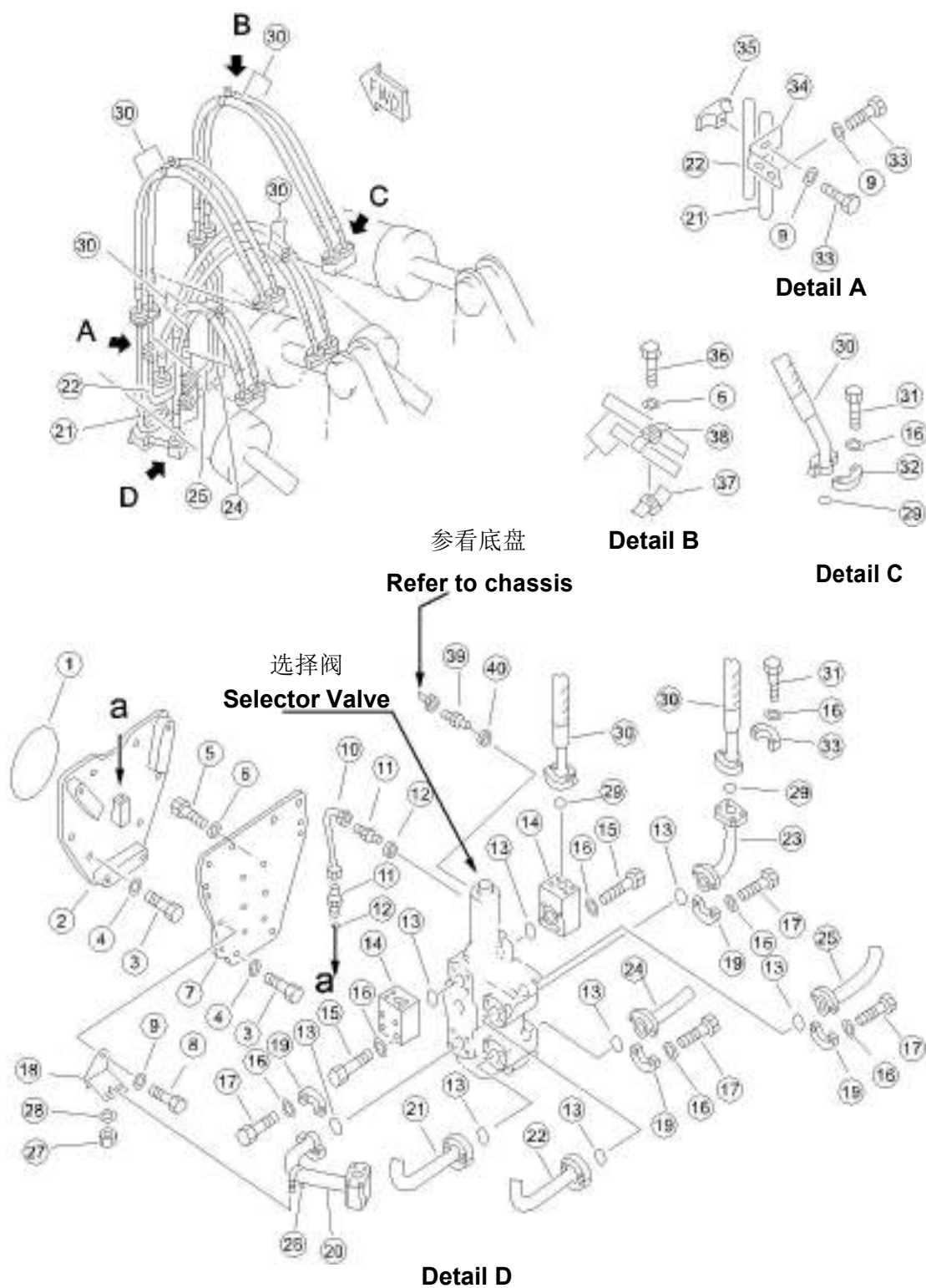

序号 NO.	部件号 PART NO.	零件名称 PART NAME		数量 Q'TY	适用机型 MODEL
1	07000-15195	O 形圈	O-ring	1	
2	195-78-45240	板	Plate	1	
3	01010-52050	螺栓 M20*50	Bolt M20*50	10	
4	01602-22060	弹簧垫圈 20	Spring washer 20	10	
5	01050-51230	螺栓 M12*1.5*30	Bolt M12*1.5*30	6	
6	01602-21236	垫圈 12	Washer 12	18	
7	195-78-45250	板	Plate	1	
8	01010-51240	螺栓 M12*40	Bolt M12*40	2	
9	01643-31232	垫圈 12	Washer 12	8	
10	195-78-22651	管	Tube	1	
11	07211-81016	接头	Nipple	2	
12	07005-01612	密封垫圈	Sealing gasket	2	
13	07000-13038	O 形圈	O-ring	8	
14	195-78-22150	弯头	Elbow	2	
15	01010-51085	螺栓 M10*85	Bolt M10*85	8	
16	01602-21030	垫圈 10	Washer 10	104	
17	01010-51035	螺栓 M10*35	Bolt M10*35	32	
18	195-78-45260	托架	Bracket	1	
19	07371-31255	法兰	Flange	16	
20	175-78-63130	弯头	Elbow	1	
21	175-78-63210	管	Tube	1	
22	175-78-63180	管	Tube	1	
23	175-78-63161	管	Tube	1	
24	175-78-63190	管	Tube	1	
25	175-78-63220	管	Tube	1	
26	07283-23450	管夹	Clip	1	
27	01599-01011	螺母 M10*1.25	Nut M10*1.25	2	
28	01643-31032	垫圈 10	Washer 10	2	
29	07000-13032	O 形圈	O-ring	16	
30	07114-01015	软管	Hose	8	
31	01010-51030	螺栓 M10*30	Bolt M10*30	64	
32	07371-31049	法兰	Flange	32	

# 松土器油缸管路 RIPPER CYLINDER PIPING

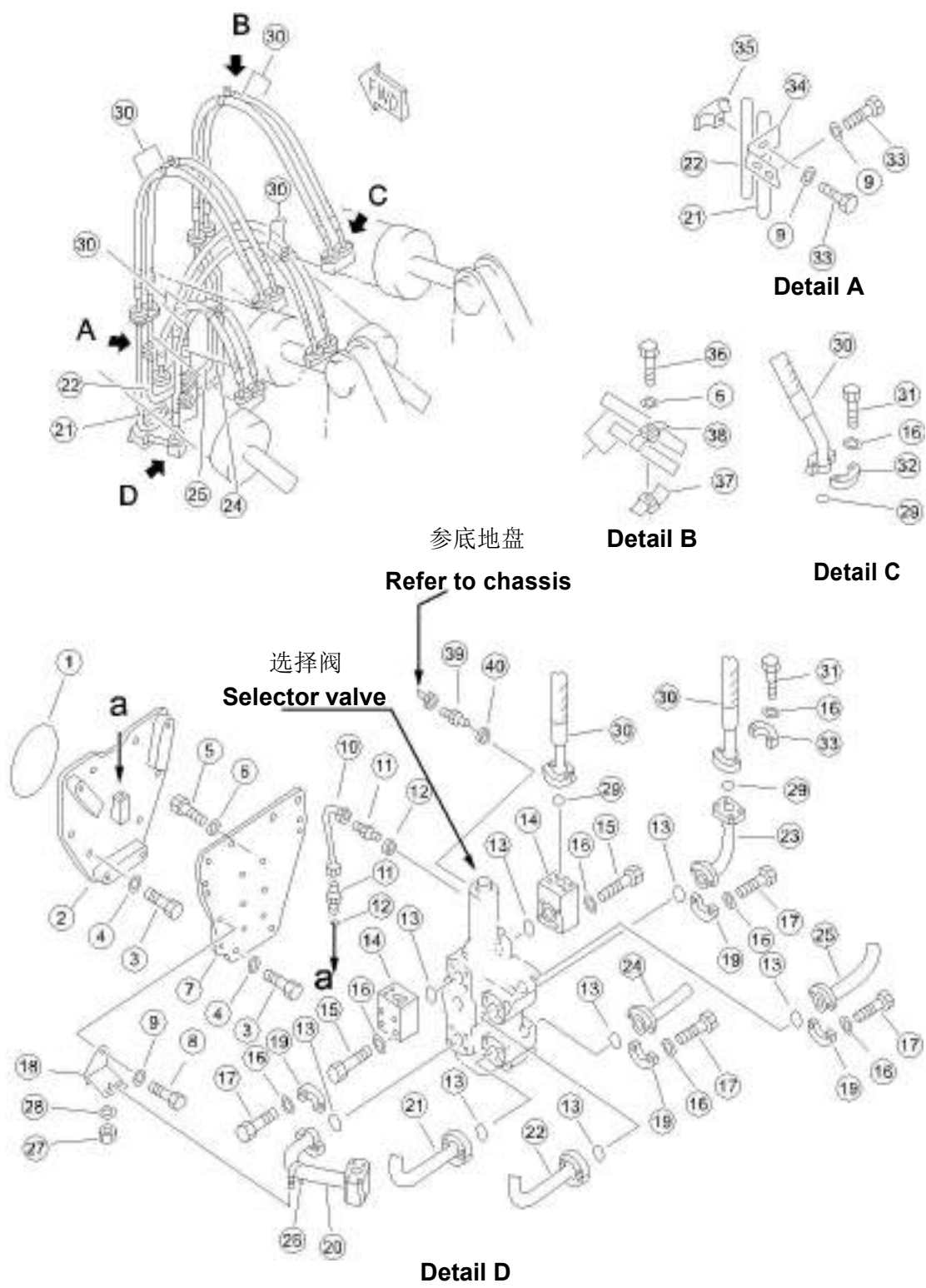

序号 NO.	部件号 PART NO.	零件名称 PART NAME		数量 Q'TY	适用机型 MODEL
33	01010-51235	螺栓 M12*35	Bolt M12*35	6	
34	195-78-45211	托板	Plate	2	
35	195-78-45270	夹	Clip	2	
36	01010-51265	螺栓 M12*65	Bolt M12*65	4	
37	195-78-22320	夹	Clip	4	
38	195-78-22330	管夹	Clip	4	
39	07230-20315	管接头	Nipple	1	
40	07002-01034	O 形圈	O-ring	1	

### DC 和 PC 阀总成 DC & PC VALVE ASS'Y

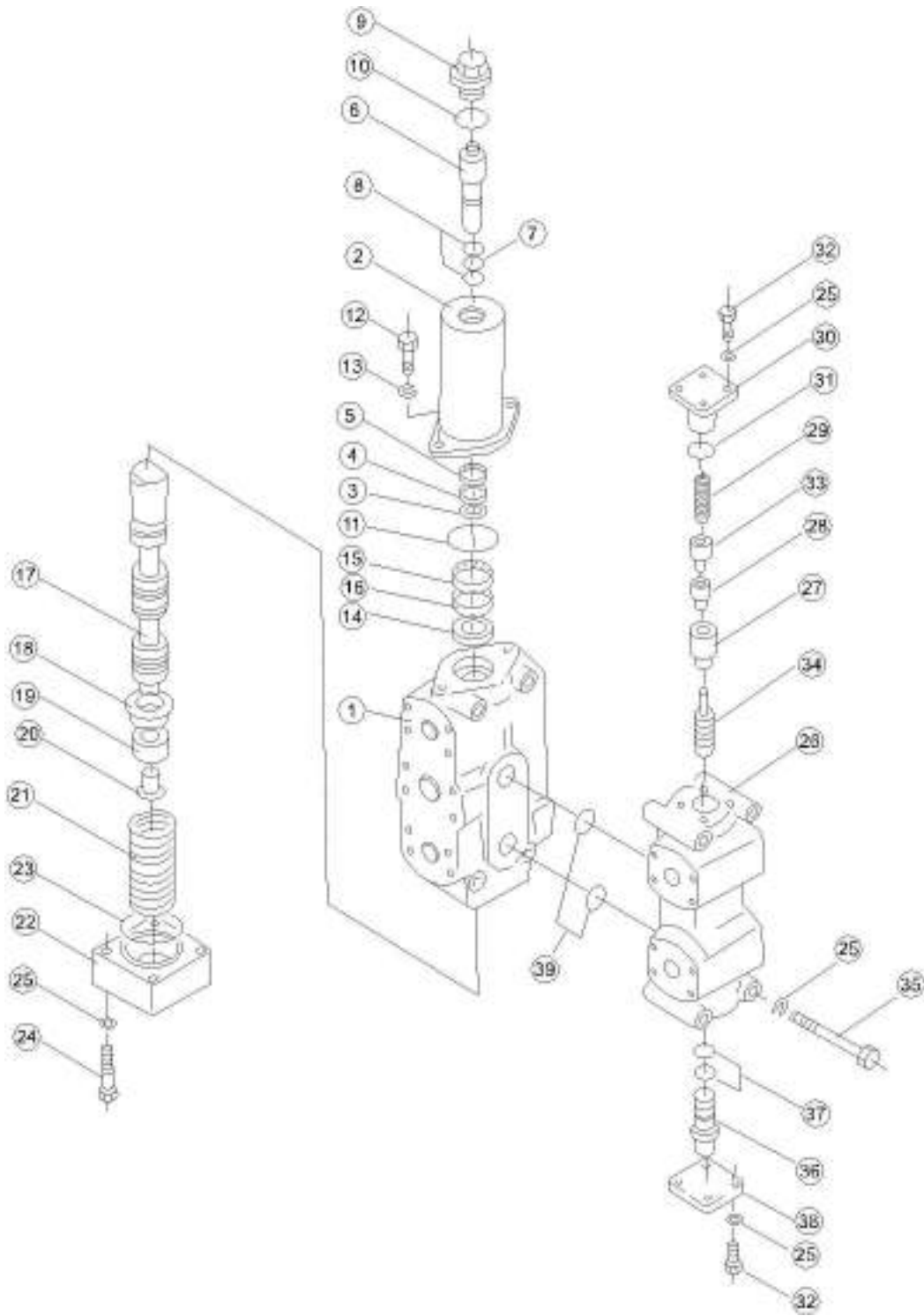

序号 NO.	部件号 PART NO.	零件名称 PART NAME		数量 Q'TY	适用机型 MODEL
1	700-61-33111	阀体	Valve body	1	
2	700-61-33410	主体	Main body	1	
3	700-61-33450	挡圈	Retainer ring	1	
4	700-61-33440	衬套	Bushing	1	
5	07016-00226	防尘圈	Ring, Dust	1	
6	700-61-33430	阀杆	Valve stem	1	
7	07000-12018	O 形圈	O-ring	1	
8	07001-02018	保护圈	Guard ring	2	
9	700-61-33420	螺塞	Screw plug	1	
10	07002-13034	O 形圈	O-ring	1	
11	07000-12065	O 形圈	O-ring	1	
12	01010-51235	螺栓 M12*35	Bolt M12*35	2	
13	01602-21236	垫圈 12	Washer 12	2	
14	07006-00040	U 型油封	U-seal	1	
15	07016-00407	防尘圈	Ring, Dust	1	
16	700-52-31310	套环	Collar	1	
17	700-61-33460	阀杆	Valve stem	1	
18	700-61-33470	护圈	Guard ring	1	
19	700-61-33510	套环	Collar	1	
20	700-61-33520	螺塞	Screw plug	1	
21	700-61-33481	弹簧	Spring	1	
22	700-61-33490	盖	Cover	1	
23	07000-12070	O 形圈	O-ring	1	
24	01010-51060	螺栓 M10*60	Bolt M10*60	4	
25	01602-21030	垫圈 10	Washer 10	16	
26	700-61-34111	阀体	Valve body	1	
27	700-61-34220	阀芯	Valve core	1	
28	700-61-34340	阀芯	Valve core	1	
29	700-61-34230	弹簧	Spring	1	
30	700-61-34141	法兰	Flange	1	
31	07000-13025	O 形圈	O-ring	1	
32	01010-51030	螺栓 M10*30	Bolt M10*30	8	
33	700-61-34510	柱塞	Plunger	1	
34	700-61-34330	阀杆	Valve stem	1	
35	01011-51000	螺栓 M10*100	Bolt M10*100	4	
36	700-61-34320	阀杆	Valve stem	1	
37	07000-12021	O 形圈	O-ring	2	
38	700-61-34310	块	Block	1	
39	07000-13035	O 形圈	O-ring	2	

# 松土器提升油缸 RIPPER LIFT CYLINDER

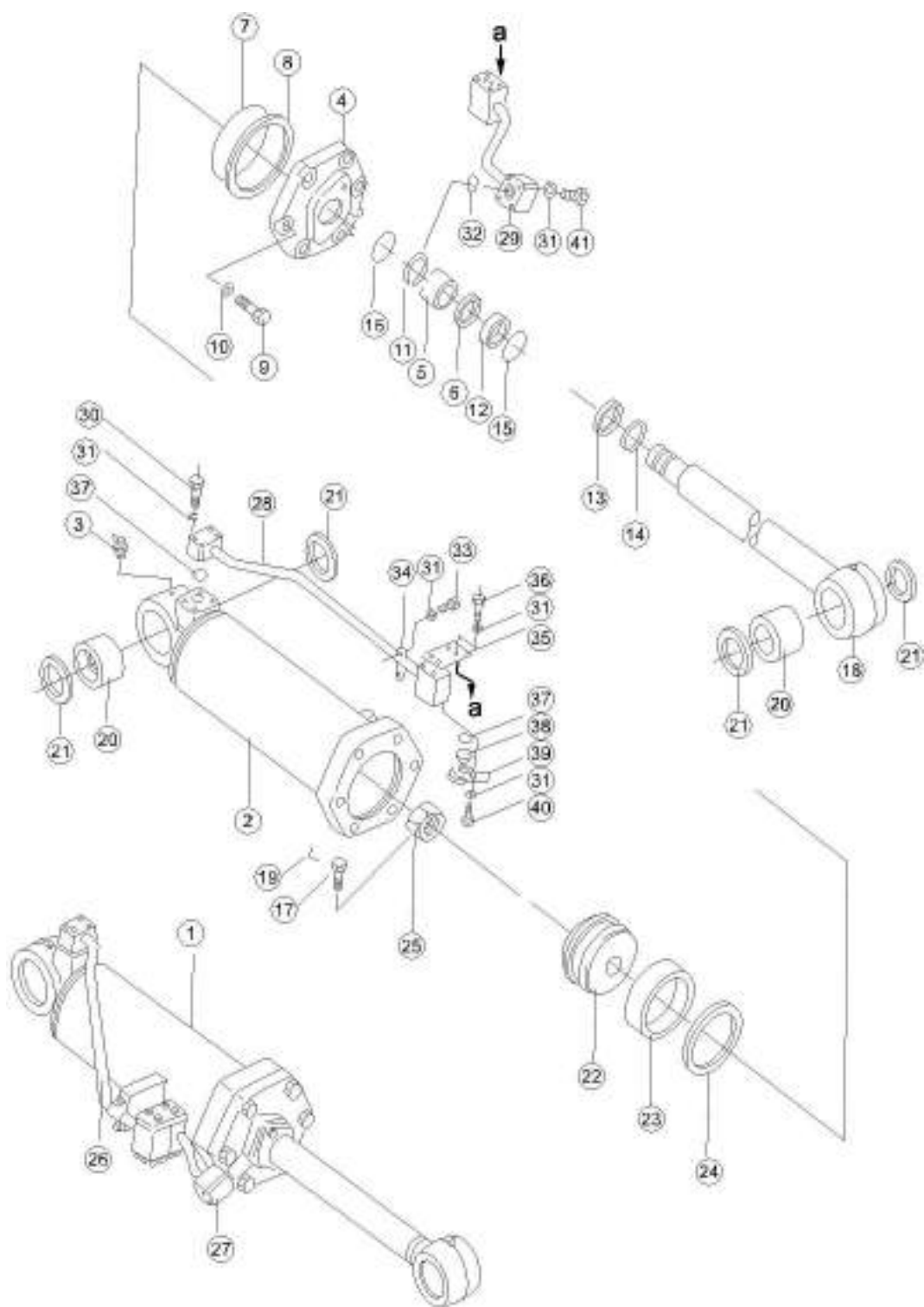

序号 NO.	部件号 PART NO.	零件名称 PART NAME	数量 Q'TY	适用机型 MODEL
0	171-64-01000	松土器提升油缸 (左) Ripper lift cylinder (L.H.)	1	
0	171-64-02000	松土器提升油缸 (右) Ripper lift cylinder (R.H.)	1	
1	171-64-01300	缸 (左) Cylinder body (L.H.)	1	
2	171-64-02200	缸 (右) Cylinder body (R.H.)	1	
3	07021-01060	油杯 60° M10*1 Oil cup 60° M10*1	2	
4	171-63-01001	缸头 Cylinder head	1	
5	07177-09035	衬套 Bushing	1	
6	171-63-01005	KY 圈 KY-Ring	1	
7	07000-15220	O 形圈 O-ring	1	
8	171-63-01002	保护圈 Guard ring	1	
9	01252-42090	螺栓 M20*90 Bolt M20*90	12	
10	01643-32060	垫圈 20 Washer 20	12	
11	171-63-01300	斯特封 Step seal	1	
12	07177-09020	衬套 Bushing	1	
13	171-63-01400	防尘圈 Ring, Dust	1	
14	07179-00113	弹性挡环 Retainer	1	
15	07000-12065	O 形圈 O-ring	1	
16	GB895.1-95	挡圈 Retainer ring	1	
17	01322-41025	紧定螺钉 Set screw	1	
18	171-64-01100	活塞杆 Piston rod	1	
19	04059-01032	铁丝 Iron wire	1	
20	07144-11110	衬套 Bushing	2	
21	07145-10110	防尘圈 Ring, Dust	4	
22	171-63-01003	活塞 Piston	1	
23	07155-02250	修整圈 Trim ring	1	
24	707-44-22080	活塞密封圈 Piston ring	1	
25	171-63-01004	螺母 Nut	1	
26	175-63-42581	管子 (左) Tube (L.H.)	1	
27	171-64-01200	管子 (左) Tube (L.H.)	1	
28	175-63-42591	管子 (右) Tube (R.H.)	1	
29	171-64-02100	管子 (右) Tube (R.H.)	1	
30	01010-51065	螺栓 M10*65 Bolt M10*65	4	

# 松土器提升油缸 RIPPER LIFT CYLINDER

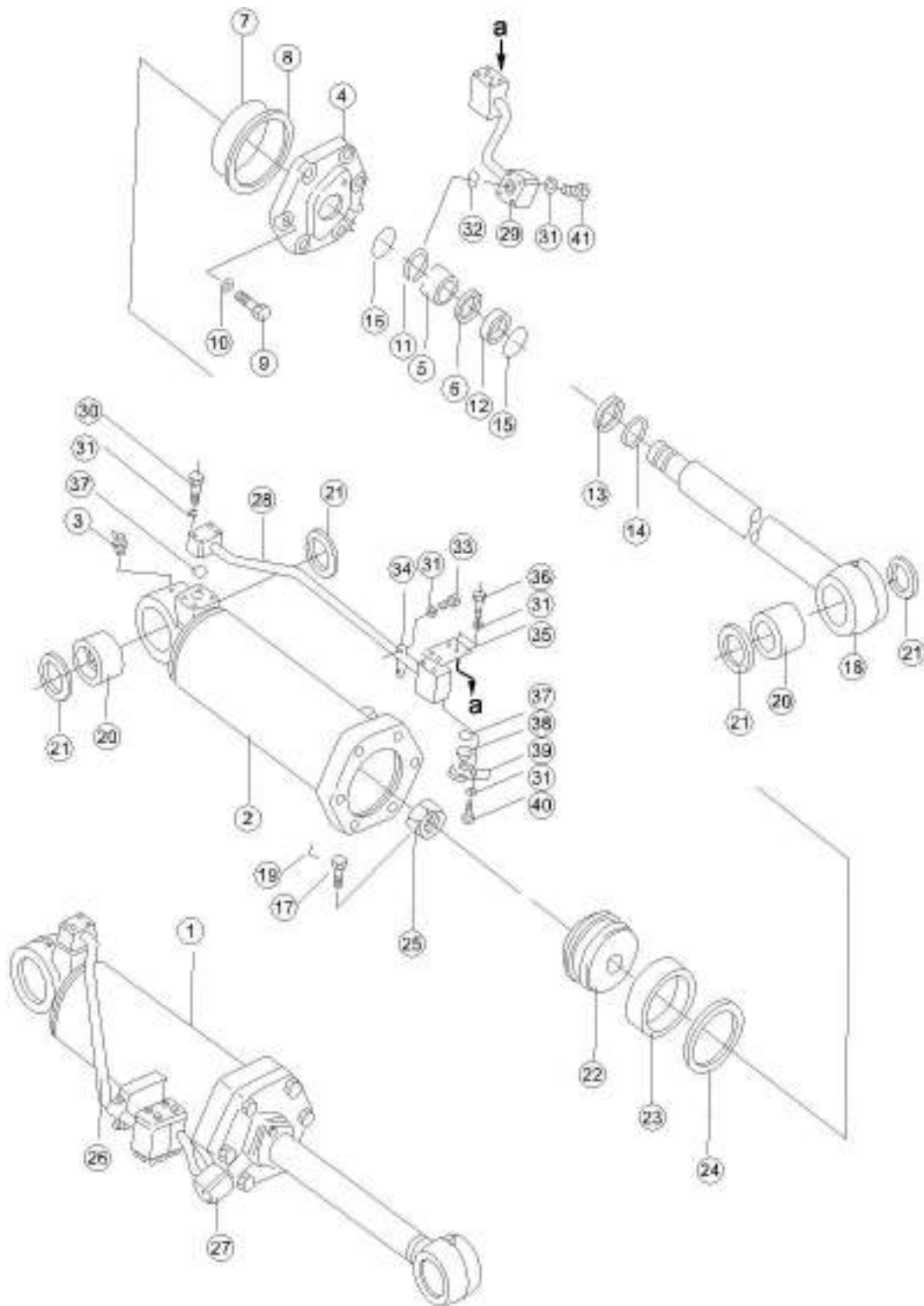

序号 NO.	部件号 PART NO.	零件名称 PART NAME		数量 Q'TY	适用机型 MODEL
31	01643-31032	垫圈 10	Washer 10	22	
32	07000-13038	O 形圈	O-ring	2	
33	01010-51020	螺栓 M10*20	Bolt M10*20	2	
34	07282-13411	管夹	Clip	1	
35	171-64-01001	板	Plate	1	
36	01010-51025	螺栓 M10*25	Bolt M10*25	4	
37	07000-13032	O 形圈	O-ring	2	
38	07378-11000	防尘盖	Cover, Dust	2	
39	07371-31049	法兰	Flange	4	
40	01010-51030	螺栓 M10*30	Bolt M10*30	8	
41	01010-51070	螺栓 M10*70	Bolt M10*70	4	

# 松土器倾斜油缸 RIPPER TILT OIL CYLINDER

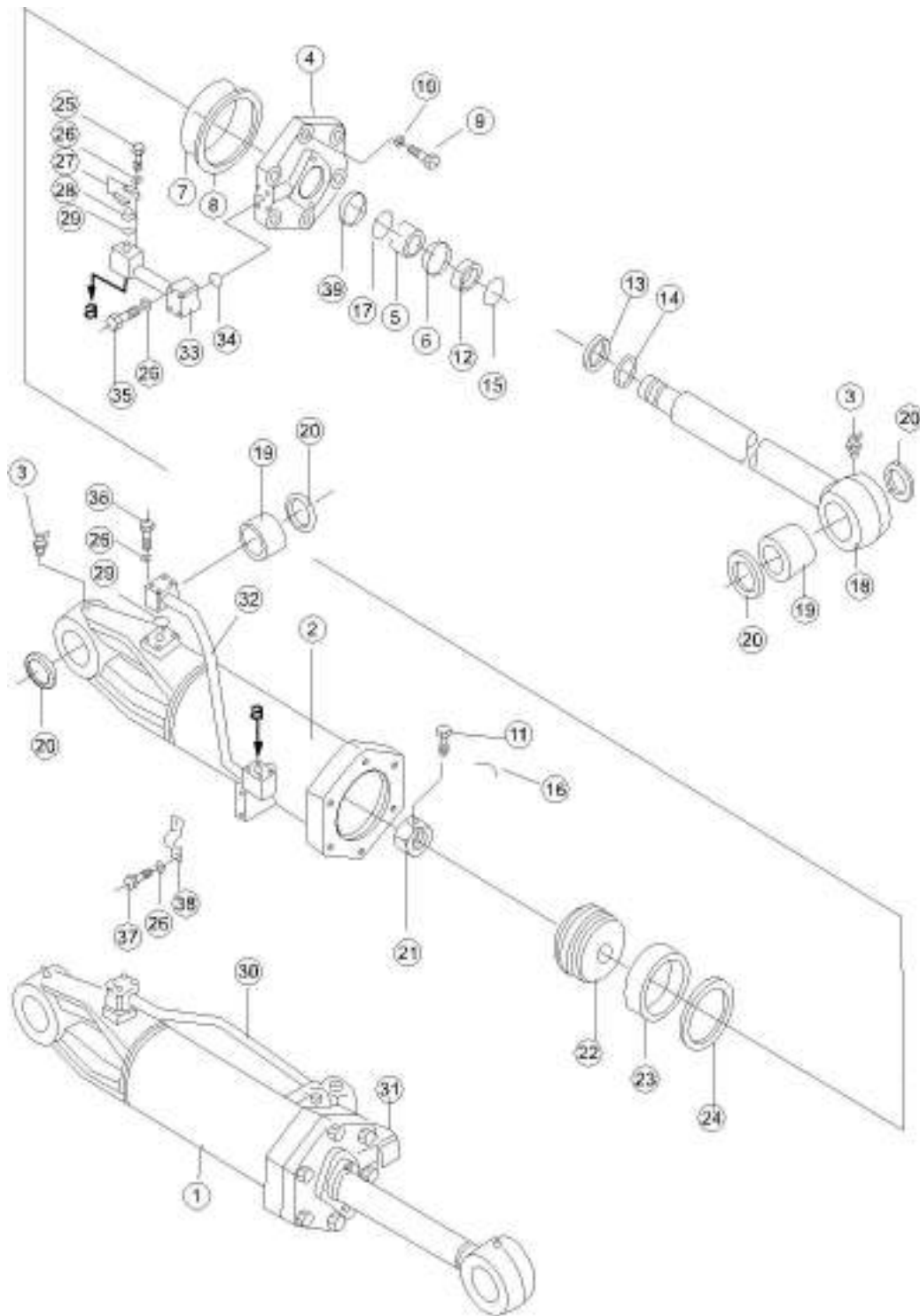

序号 NO.	部件号 PART NO.	零件名称 PART NAME	数量 Q'TY	适用机型 MODEL
0	171-64-03000	松土器倾斜油缸 (左)	1	
0	171-64-04000	松土器倾斜油缸 (右)	1	
1	171-64-03300	缸体 (左)	1	
2	171-64-04200	油缸 (右)	1	
3	07021-01060	油杯 60° M10*1	2	
4	171-63-01001	缸头	1	
5	07177-09035	衬套	1	
6	171-63-01005	KY 圈	1	
7	07000-15215	O 形圈	1	
8	171-63-01002	保护圈	1	
9	01252-42090	螺栓 M20*90	12	
10	01643-32060	垫圈 20	12	
11	01322-41025	紧定螺钉	1	
12	07177-09020	衬套	1	
13	171-63-01400	防尘圈	1	
14	07179-00113	弹性挡环	1	
15	07000-12065	O 形圈	1	
16	04059-01032	铁丝	1	
17	GB895.1-95	挡圈	1	
18	175-63-43121	活塞杆	1	
19	07144-11110	衬套	2	
20	07145-00110	防尘圈	4	
21	171-63-01004	螺母	1	
22	171-63-01003	活塞	1	
23	07155-02250	修整圈	1	
24	707-44-22080	活塞密封圈	1	
25	01010-51030	螺栓 M10*30	8	
26	01643-31032	垫圈 10	18	
27	07371-31049	法兰	4	
28	07378-11000	防尘盖	2	
29	07000-13032	O 形圈	2	
30	171-64-03400	管 (左)	1	



序号 NO.	部件号 PART NO.	零件名称 PART NAME		数量 Q'TY	适用机型 MODEL
31	171-64-03200	管 ( 左 )	Tube (L.H.)	1	
32	171-64-04300	管 ( 右 )	Tube (R.H.)	1	
33	171-64-04100	管 ( 右 )	Tube (R.H.)	1	
34	07000-13038	O 形圈	O-ring	1	
35	01010-51070	螺栓 M10*70	Bolt M10*70	4	
36	01010-51065	螺栓 M10*65	Bolt M10*65	4	
37	01010-51020	螺栓 M10*20	Bolt M10*20	2	
38	07282-13411	管夹	Clip	1	
39	171-63-01300	斯特封	Step seal	1	

# 升降操纵伺服阀 LIFT CONTROL SERVO VALVE

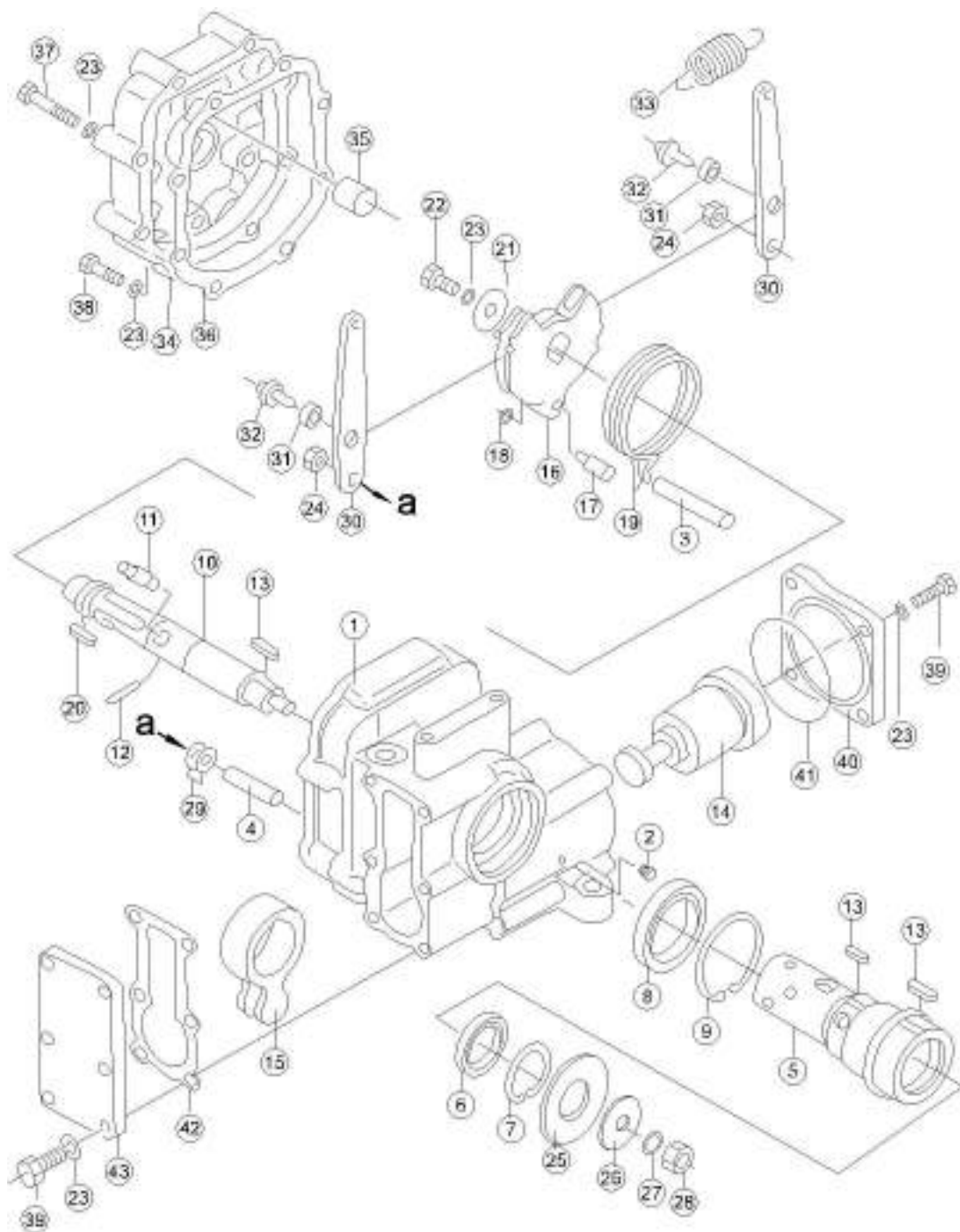

序号 NO.	部件号 PART NO.	零件名称 PART NAME		数量 Q'TY	适用机型 MODEL
0	702-12-13001	升降操纵伺服阀	Lift control servo valve	1	
1	702-12-13110	阀体	Valve body	1	
2	07043-70108	螺塞	Screw plug	2	
3	702-12-12140	销	Pin	1	
4	702-12-12150	销	Pin	2	
5	702-12-12160	轴套	Sleeve	1	
6	702-12-12390	油封	Oil seal	1	
7	04065-04018	挡圈	Retainer ring	1	
8	702-12-12410	油封	Oil seal	1	
9	04065-06020	挡圈	Retainer ring	1	
10	702-12-12170	转子	Roller	1	
11	702-12-12180	销	Pin	1	
12	04025-00316	圆柱销	Cylindrical pin	1	
13	04000-10520	平键	Flat key	3	
14	702-12-12191	活塞	Piston	1	
15	702-12-12210	杠杆	Lever	1	
16	702-12-12221	止动片	Stopper	1	
17	702-12-12230	销	Pin	1	
18	702-12-12240	卡环	Snap ring	1	
19	702-12-12251	弹簧	Spring	1	
20	04000-10515	平键	Flat key	1	
21	702-12-12420	垫圈	Washer	1	
22	01010-50816	螺栓 M8*16	Bolt M8*16	1	
23	01602-20825	垫圈 8	Washer 8	19	
24	702-12-12361	衬套	Bushing	2	
25	702-12-12280	垫圈	Washer	1	
26	702-12-12270	垫圈	Washer	1	
27	01580-11008	螺母 M10	Nut M10	1	
28	01602-21030	垫圈 10	Washer 10	1	
29	01641-21016	垫圈 10	Washer 10	4	
30	702-12-12291	杠杆	Lever	2	
31	702-12-12310	轴承	Bearing	2	



序号 NO.	部件号 PART NO.	零件名称 PART NAME	数量 Q'TY	适用机型 MODEL
32	702-12-12320	滚子 Roller	2	
33	702-12-12331	弹簧 Spring	1	
34	702-12-13120	盖 Cover	1	
35	702-12-12340	销 Pin	1	
36	702-12-13140	垫 Pad	1	
37	01010-50845	螺栓 M8*45 Bolt M8*45	6	
38	01010-50835	螺栓 M8*35 Bolt M8*35	2	
39	01010-50825	螺栓 M8*25 Bolt M8*25	10	
40	702-12-13160	盖 Cover	1	
41	07000-E2070	O 形圈 O-ring	1	
42	702-12-13150	垫 Pad	1	
43	702-12-13130	盖 Cover	1	

# 倾斜及松土器操纵伺服阀 TILT AND RIPPER CONTROL SERVO VALVE

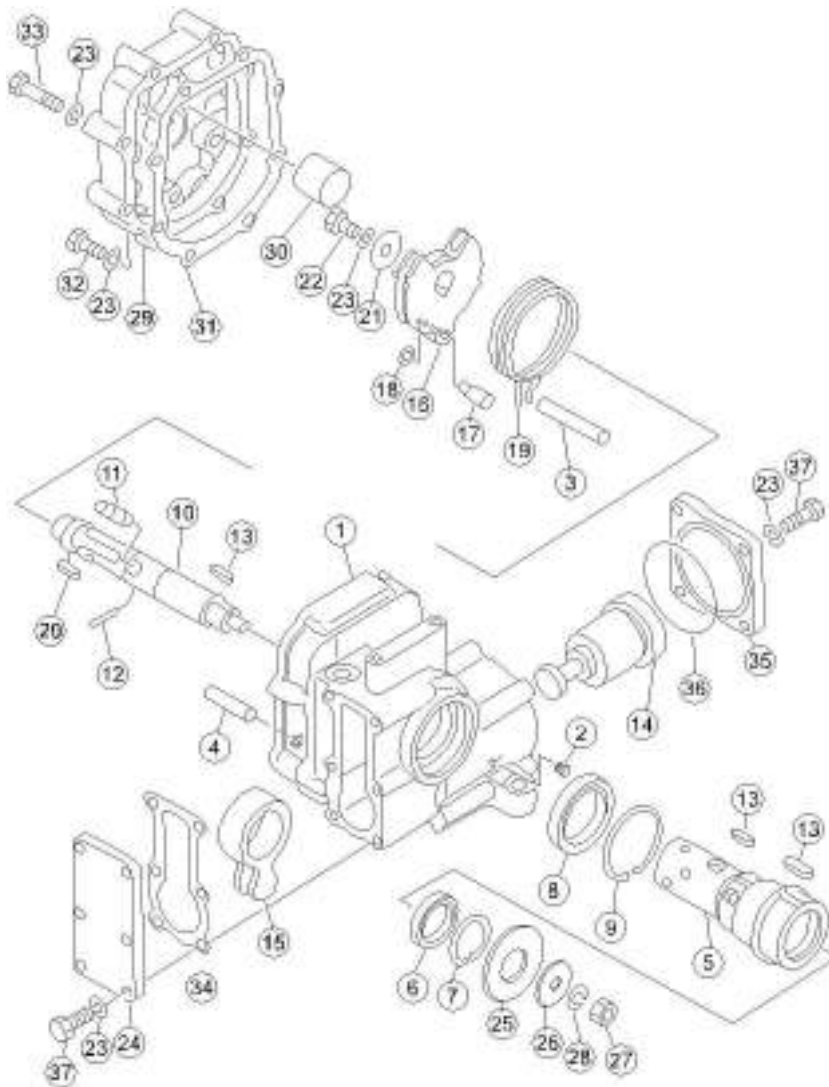

序号 NO.	部件号 PART NO.	零件名称 PART NAME	数量 Q'TY	适用机型 MODEL
1	702-12-13110	阀体 Valve body	1	
2	07043-70108	螺塞 Screw plug	2	
3	702-12-12140	销 Pin	1	
4	702-12-12150	销 Pin	2	
5	702-12-12160	轴套 Sleeve	1	
6	702-12-12390	油封 Oil seal	1	
7	04065-04018	挡圈 Retainer ring	1	
8	702-12-12410	油封 Oil seal	1	
9	04065-06020	挡圈 Retainer ring	1	
10	702-12-12170	转子 Roller	1	
11	702-12-12180	销 Pin	1	
12	04025-00316	圆柱销 Cylindrical pin	1	
13	04000-10520	平键 Flat key	3	
14	702-12-12191	活塞 Piston	1	
15	702-12-12210	杠杆 Lever	1	
16	702-12-12451	止动片 Stopper	1	
17	702-12-12230	销 Pin	1	
18	702-12-12240	卡环 Snap ring	1	
19	702-12-12251	弹簧 Spring	1	
20	04000-10515	平键 Flat key	1	
21	702-12-12420	垫圈 Washer	1	
22	01010-50816	螺栓 M8*16 Bolt M8*16	1	
23	01602-20825	垫圈 8 Washer 8	19	
24	702-12-13130	盖 Cover	1	
25	702-12-12280	垫圈 Washer	1	
26	702-12-12270	垫圈 Washer	1	
27	01580-11008	螺母 M10 Nut M10	1	
28	01602-21030	垫圈 10 Washer 10	1	
29	702-12-13220	盖 Cover	1	
30	702-12-13210	销 Pin	1	
31	702-12-13140	垫 Pad	1	
32	01010-50835	螺栓 M8*35 Bolt M8*35	2	
33	01010-50845	螺栓 M8*45 Bolt M8*45	6	
34	702-12-13150	垫 Pad	1	
35	702-12-13160	盖 Cover	1	
36	07000-E2070	O形圈 O-ring	1	
37	01010-50825	螺栓 M8*25 Bolt M8*25	10	

# 伺服管路总成 SERVO PIPING ASS'Y

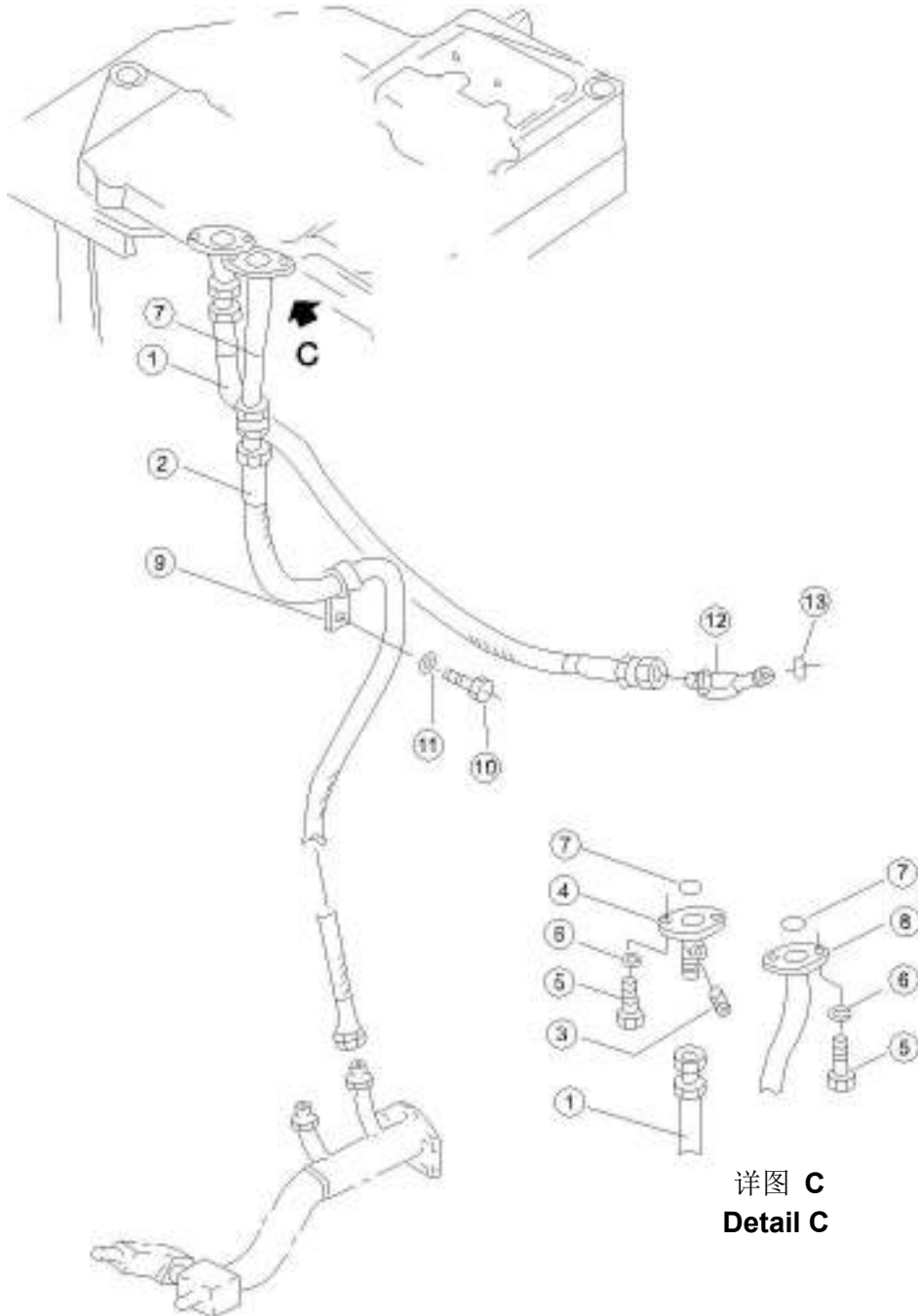

详图 C  
Detail C

序号 NO.	部件号 PART NO.	零件名称 PART NAME	数量 Q'TY	适用机型 MODEL
1	07102-20410	软管 Hose	1	
2	07102-20413	软管 Hose	1	
3	07042-20108	螺塞 Screw plug	1	
4	195-61-21391	管子 Tube	1	
5	01010-51045	螺栓 M10*45 Bolt M10*45	4	
6	01602-21030	垫圈 10 Washer 10	4	
7	07000-13025	O 形圈 O-ring	2	
8	195-61-21471	管子 Tube	1	
9	08036-12514	线夹 Wire clip	3	
10	01010-51025	螺栓 M10*25 Bolt M10*25	1	
11	01643-31032	垫圈 10 Washer 10	1	
12	07236-10422	弯头 Elbow	1	
13	07002-12034	O 形圈 O-ring	1	

### 伺服阀与阀座 SERVO VALVE AND VALVE SEAT

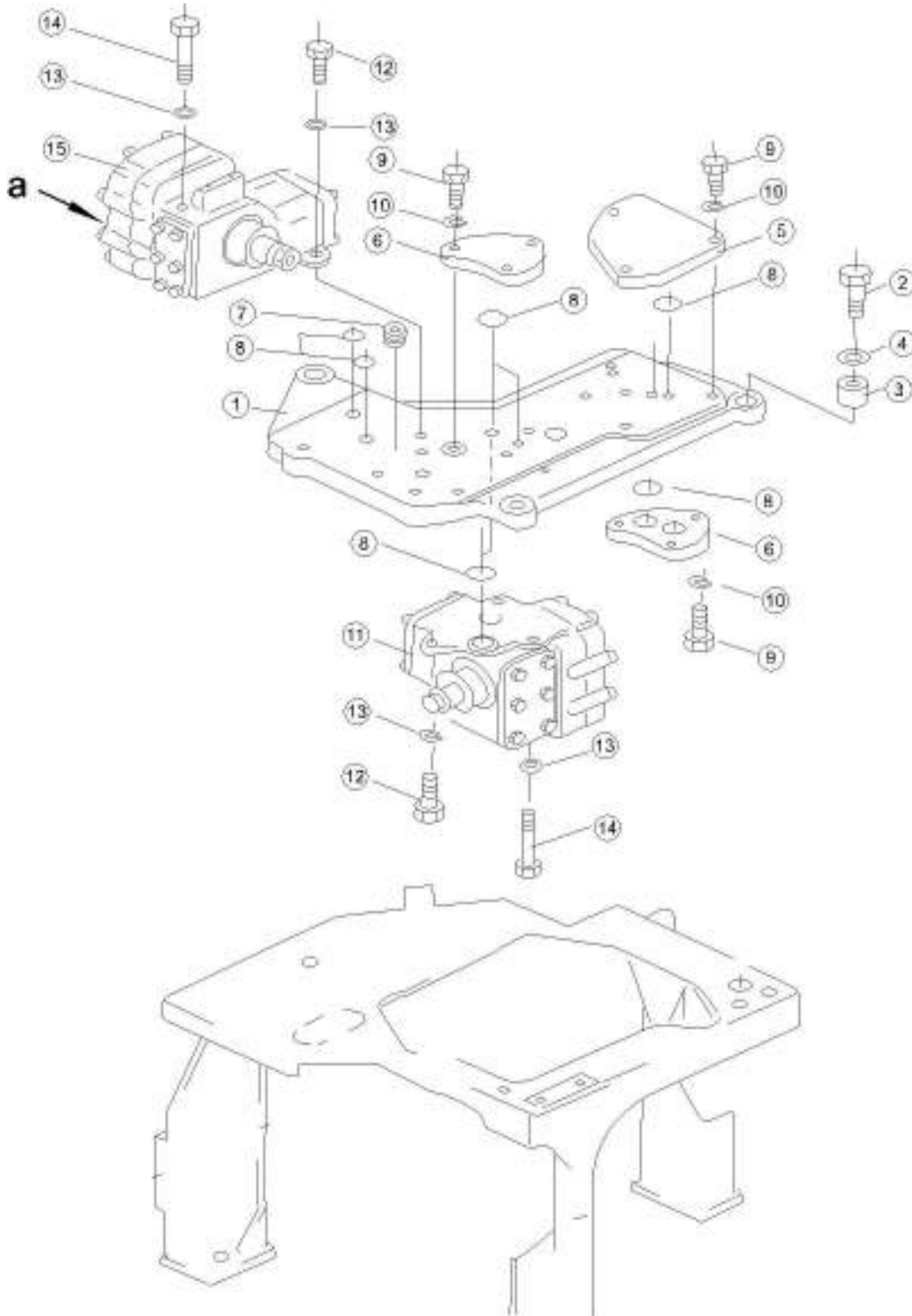

序号 NO.	部件号 PART NO.	零件名称 PART NAME	数量 Q'TY	适用机型 MODEL
1	195-61-21230	阀座 Valve seat	1	
2	01010-51485	螺栓 M14*85 Bolt M14*85	3	
3	198-21-12240	轴套 Sleeve	3	
4	01643-31445	垫圈 14 Washer 14	3	
5	195-61-21420	板 Plate	1	
6	195-61-21430	垫板 Plate	1	
7	07043-70617	螺塞 Screw plug	7	
8	07000-13022	O 形圈 O-ring	10	
9	01010-51030	螺栓 M10*30 Bolt M10*30	9	
10	01602-21030	垫圈 10 Washer 10	9	
11	702-12-14000	倾斜及松土器操纵伺服 阀 Tilt and ripper control servo valve	1	
12	01010-51040	螺栓 M10*40 Bolt M10*40	4	
13	01643-31032	垫圈 10 Washer 10	6	
14	01011-51040	螺栓 M10*140 Bolt M10*140	2	
15	702-12-13001	升降操纵伺服阀 Lift control servo valve	1	

# 铲刀操纵杆 BLADE CONTROL LEVER

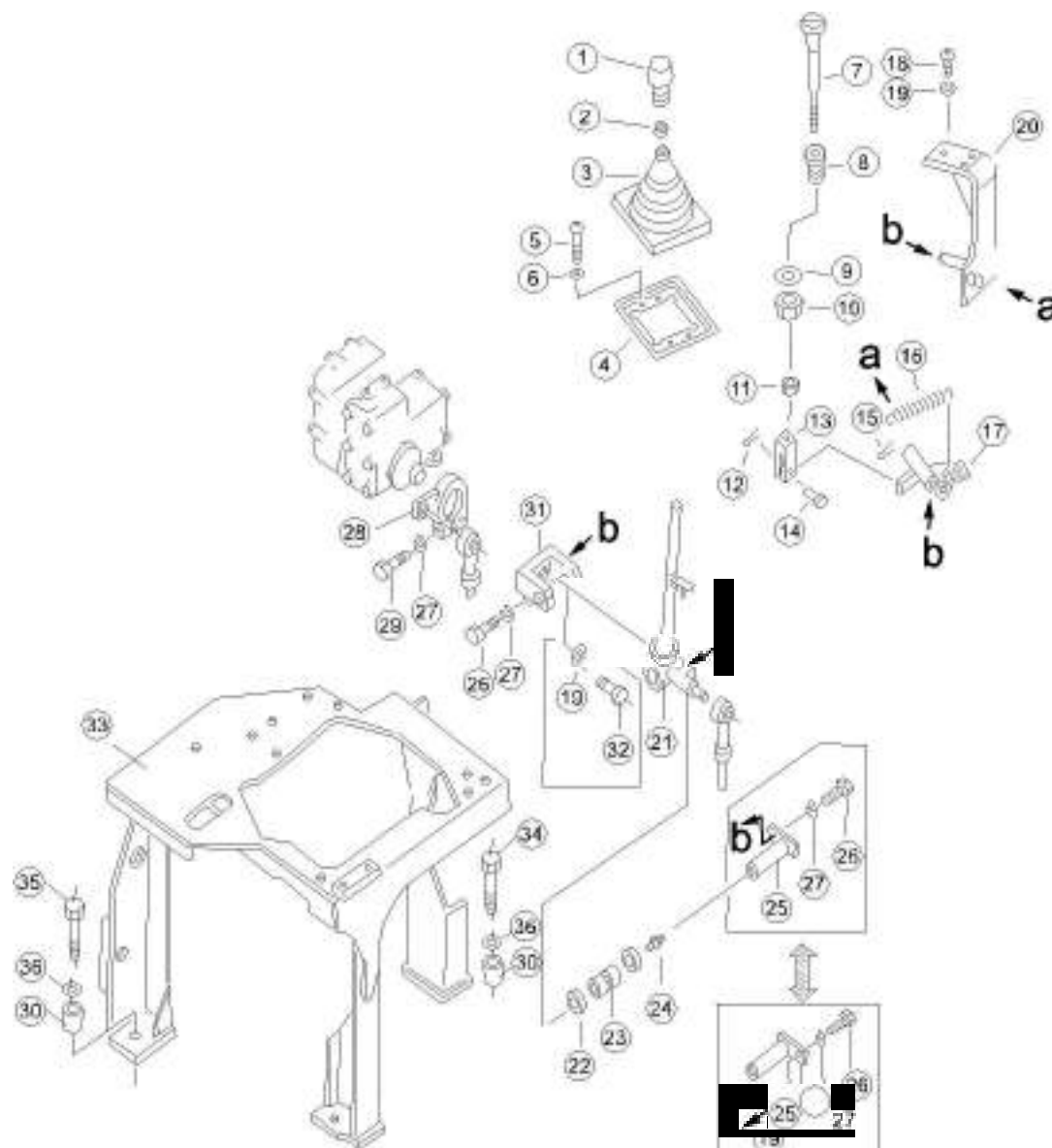

带零件只用于定位  
Parts With Are Use Only For Fix Position

控制杆的定位零件  
Fix Position Parts For Lever

序号 NO.	部件号 PART NO.	零件名称 PART NAME	数量 Q'TY	适用机型 MODEL
1	16Y-86C-11000	手柄 Handle	1	
2	195-43-44220	螺母 Nut	1	
3	195-61-45140	护罩 Guard	1	
4	23Y-86B-00002	座 Seat	1	
5	01220-40508	螺钉 M5*8 Screw M5*8	4	
6	01601-20513	垫圈 5 Washer 5	4	
7	23Y-86B-02000	按钮 Button	1	
8	175-61-31750	凸块 Block	1	
9	01640-22232	垫圈 22 Washer 22	1	
10	195-61-45230	螺母 Nut	1	
11	01580-10806	螺母 M8 Nut M8	1	
12	04050-13018	开口销 Cotter pin	1	
13	04211-20844	叉口板 Fork plate	1	
14	04205-10822	销轴 Pin shaft	1	
15	04050-12016	开口销 Cotter pin	1	
16	195-61-45290	弹簧 Spring	1	
17	171-86-02000	摇臂 Rock arm	1	
18	01010-50816	螺栓 M8*16 Bolt M8*16	3	
19	01643-30823	垫圈 8 Washer 8	5	
20	23Y-86B-03000	支架 Bracket	1	
21	171-86-01000	操纵杆 Control lever	1	
22	06122-02504	防尘密封圈 Ring, Dust	2	
23	GB290-HK2516	冲压外圈滚针轴承 Needle roller bearing	2	
24	07020-01021	油杯 M10*1 Oil cup M10*1	1	
25	175-61-13632	轴 Shaft	1	
26	01010-50820	螺栓 M8*20 Bolt M8*20	3	
27	01602-20825	垫圈 8 Washer 8	4	
28	175-61-13641	摇臂 Rock arm	1	
29	01010-50840	螺栓 M8*40 Bolt M8*40	1	
30	198-21-12240	轴套 Sleeve	3	
31	175-61-13621	架 Frame	1	
32	01010-50835	螺栓 M8*35 Bolt M8*35	1	
33	171-86-03000	支架 Bracket	1	
34	01010-51475	螺栓 M14*75 Bolt M14*75	1	
35	01010-51465	螺栓 M14*65 Bolt M14*65	2	
36	01643-31445	垫圈 14 Washer 14	3	

# 铲刀操纵联动机构 BLADE CONTROL LINKAGE

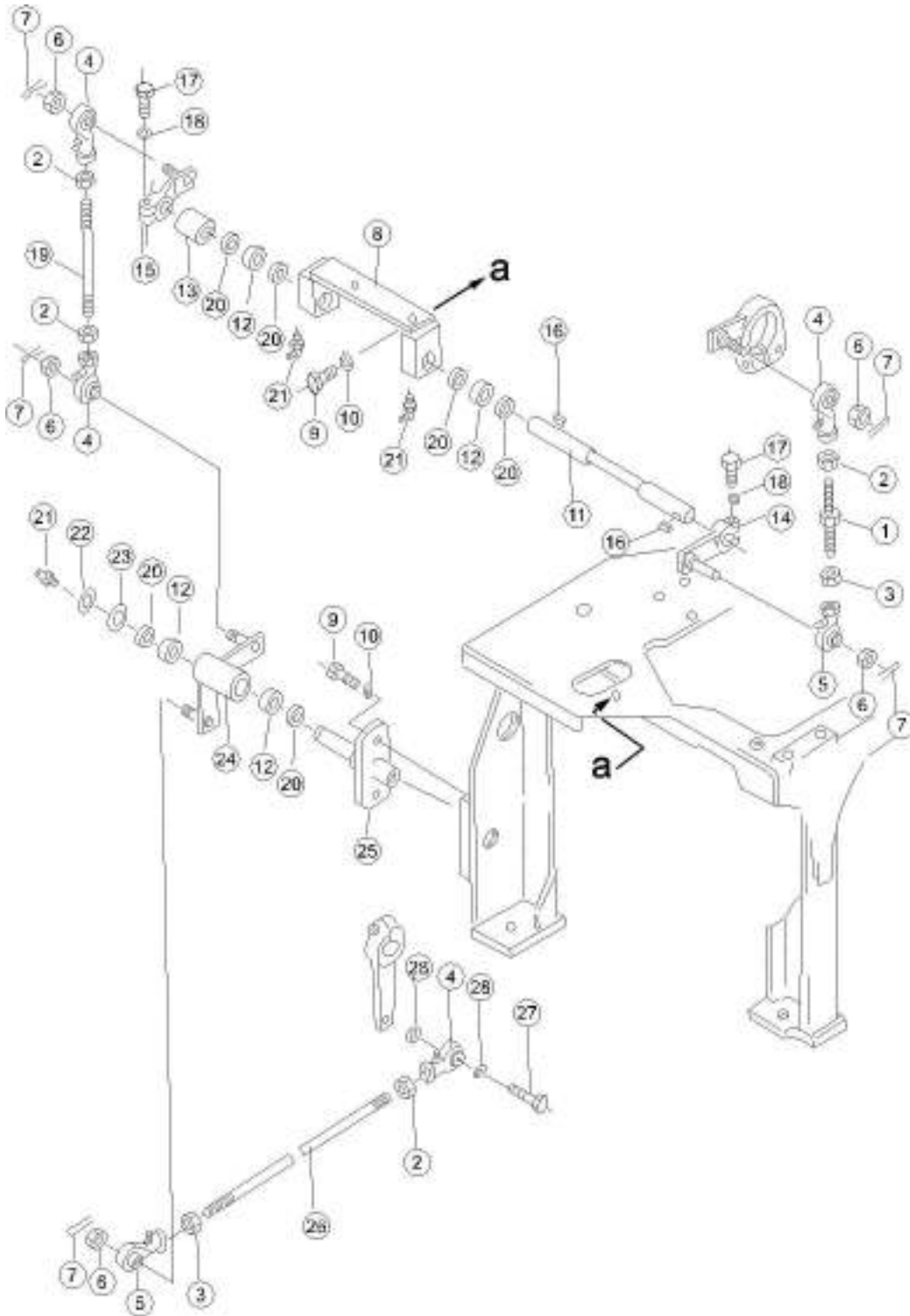

序号 NO.	部件号 PART NO.	零件名称 PART NAME		数量 Q'TY	适用机型 MODEL
1	04248-31211	杆	Lever	1	
2	01582-11210	螺母 M12*1.5	Nut M12*1.5	4	
3	01508-41207	螺母 M12*1.5 左	Nut (L.H.) M12*1.5	2	
4	04250-41265	关节轴承	Joint bearing	4	
5	04250-61265	关节轴承	Joint bearing	2	
6	01593-31210	螺母 M12*1.5	Nut M12*1.5	5	
7	04050-13020	开口销	Cotter pin	5	
8	195-61-21281	托架	Bracket	1	
9	01010-51230	螺栓 M12*30	Bolt M12*30	4	
10	01602-21236	垫圈 12	Washer 12	4	
11	175-61-13662	轴	Shaft	1	
12	GB290-HK2016	冲压外圈滚针轴承	Needle roller bearing	4	
13	195-61-21321	套管	Sleeve	1	
14	195-61-21290	摇臂	Rock arm	1	
15	175-61-21290	杆	Lever	1	
16	04010-10519	半圆键	Woodruff Key	2	
17	01010-50830	螺栓 M8*30	Bolt M8*30	2	
18	01602-20825	垫圈 8	Washer 8	2	
19	04245-41217	杆	Lever	1	
20	06122-02004	防尘密封圈	Ring, Dust	6	
21	07020-01021	油杯 M10*1	Oil cup M10*1	3	
22	04064-02012	挡圈	Retainer ring	1	
23	01640-22032	垫圈 20	Washer 20	1	
24	175-61-21310	摇臂	Rock arm	1	
25	195-61-21312	隔套	Spacer	1	
26	04248-31257	杆	Lever	1	
27	01090-51240	螺栓 M12*1.5*40	Bolt M12*1.5*40	1	
28	04254-11232	垫圈	Washer	2	

## 铲刀倾斜与松土器操纵联动机构 BLADE TILT AND RIPPER CONTROL LINKAGE

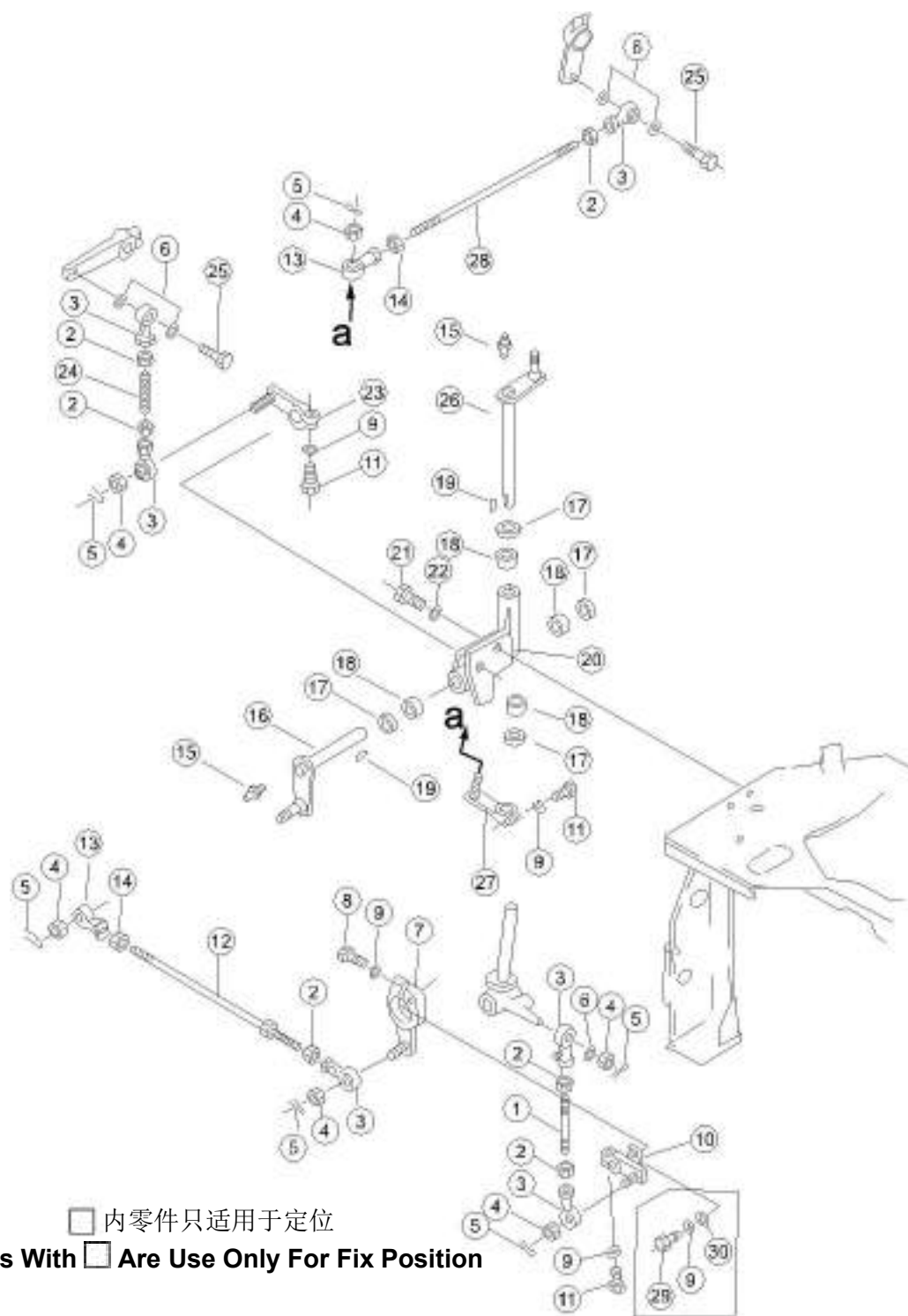

序号 NO.	部件号 PART NO.	零件名称 PART NAME		数量 Q'TY	适用机型 MODEL
1	04245-41213	杆	Lever	1	
2	01582-11210	螺母 M12*1.5	Nut M12*1.5	6	
3	04250-41265	关节轴承	Joint bearing	6	
4	01593-31210	螺母 M12*1.5	Nut M12*1.5	6	
5	04050-13020	开口销	Cotter pin	6	
6	04254-11232	垫圈	Washer	5	
7	175-61-13691	摇臂	Rock arm	1	
8	01010-50840	螺栓 M8*40	Bolt M8*40	1	
9	01602-20825	垫圈 8	Washer 8	5	
10	175-61-13681	摇臂	Rock arm	1	
11	01010-50830	螺栓 M8*30	Bolt M8*30	3	
12	04248-31230	杆	Lever	1	
13	04250-61265	关节轴承	Joint bearing	2	
14	01508-41207	螺母 M12*1.5 左	Nut (L.H.) M12*1.5	2	
15	07020-01021	油杯 M10*1	Oil cup M10*1	2	
16	195-61-21240	轴	Shaft	1	
17	06122-02004	防尘密封圈	Ring, Dust	4	
18	GB290-HK2016	冲压外圈滚针轴承	Needle roller bearing	4	
19	04010-00519	半圆键	Woodruff Key	2	
20	175-61-21280	托架	Bracket	1	
21	01010-51235	螺栓 M12*35	Bolt M12*35	2	
22	01643-31232	垫圈 12	Washer 12	2	
23	195-61-21290	摇臂	Rock arm	1	
24	175-61-13870	杆	Lever	1	
25	01090-51240	螺栓 M12*1.5*40	Bolt M12*1.5*40	2	
26	195-78-42291	轴	Shaft	1	
27	195-78-42310	拉杆	Lever	1	
28	04248-31237	杆	Lever	1	
29	01010-50825	螺栓 M8*25	Bolt M8*25	1	
30	01643-30823	垫圈 8	Washer 8	1	

## 松土器操纵杆 (1/2) RIPPER CONTROL LEVER (1/2)

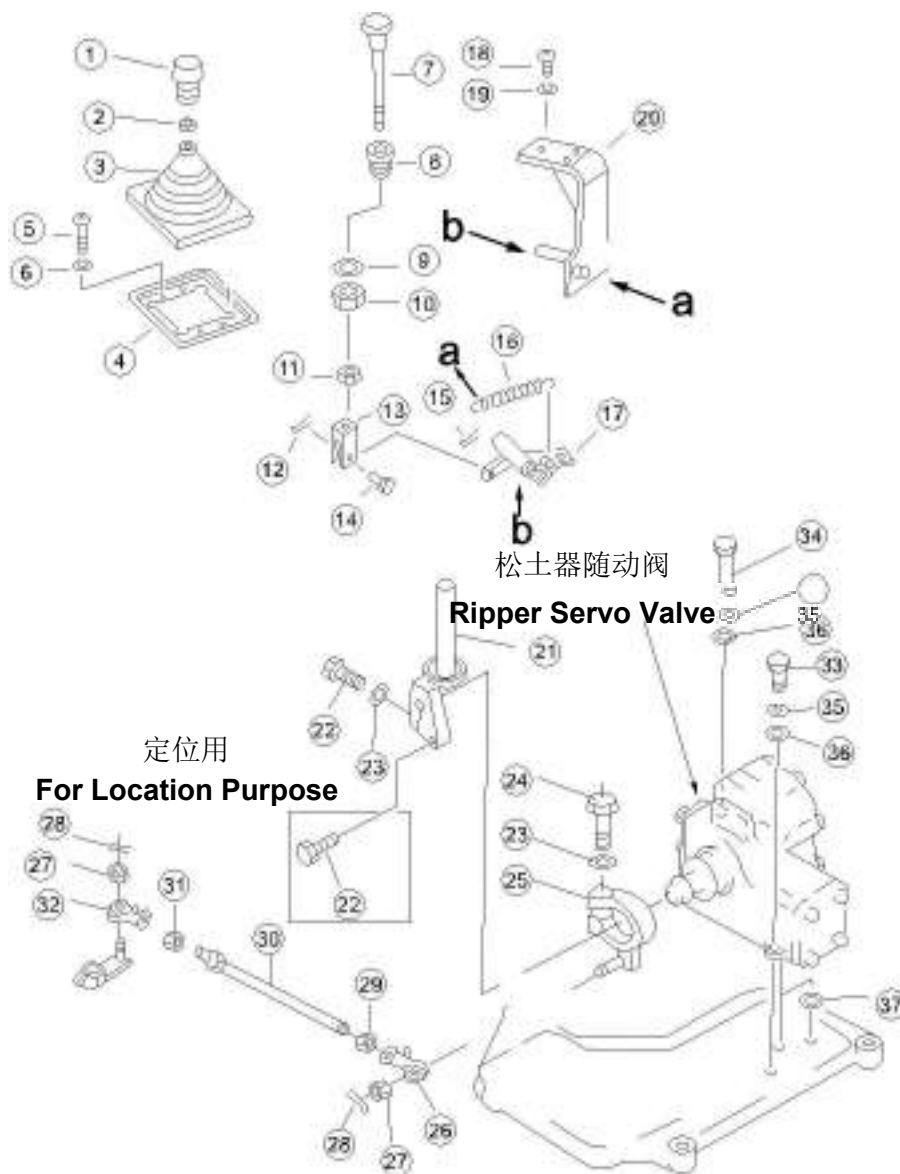

序号 NO.	部件号 PART NO.	零件名称 PART NAME		数量 Q'TY	适用机型 MODEL
1	171-87-02000	手柄	Handle	1	
2	195-43-44220	螺母	Nut	1	
3	195-61-45140	护罩	Guard	1	
4	23Y-86B-00002	座	Seat	1	
5	01220-40508	螺钉 M5*8	Screw M5*8	4	
6	01601-20513	垫圈 5	Washer 5	4	
7	23Y-86B-02000	按钮	Button	1	
8	175-61-31750	凸块	Block	1	
9	01640-22232	垫圈 22	Washer 22	1	
10	195-61-45230	螺母	Nut	1	
11	01580-10806	螺母 M8	Nut M8	1	
12	04050-13018	开口销	Cotter pin	1	
13	04211-20844	叉口板	Fork plate	1	
14	04205-10822	销轴	Pin shaft	1	
15	04050-02015	开口销	Cotter pin	1	
16	195-61-45290	弹簧	Spring	1	
17	23Y-86B-04000	摇臂	Rock arm	1	
18	01010-50816	螺栓 M8*16	Bolt M8*16	3	
19	01643-30823	垫圈 8	Washer 8	3	
20	23Y-86B-03000	支架	Bracket	1	
21	171-87-01000	操纵杆	Control lever	1	
22	01010-50835	螺栓 M8*35	Bolt M8*35	2	
23	01602-20825	垫圈 8	Washer 8	2	
24	01010-50840	螺栓 M8*40	Bolt M8*40	1	
25	195-78-42360	杠杆	Lever	1	
26	04250-61265	关节轴承	Joint bearing	1	
27	01593-31210	螺母 M12*1.5	Nut M12*1.5	2	
28	04050-13020	开口销	Cotter pin	2	
29	01508-41207	螺母 M12*1.5 左	Nut (L.H.) M12*1.5	1	
30	04248-31228	杆	Lever	1	
31	01582-11210	螺母 M12*1.5	Nut M12*1.5	1	
32	04250-41265	关节轴承	Joint bearing	1	
33	01010-51040	螺栓 M10*40	Bolt M10*40	2	
34	01011-51045	螺栓 M10*145	Bolt M10*145	1	
35	01602-21030	垫圈 10	Washer 10	3	
36	01643-31032	垫圈 10	Washer 10	3	
37	07000-13022	O 形圈	O-ring	2	

# 松土器操纵杆 (2/2) RIPPER CONTROL LEVER (2/2)

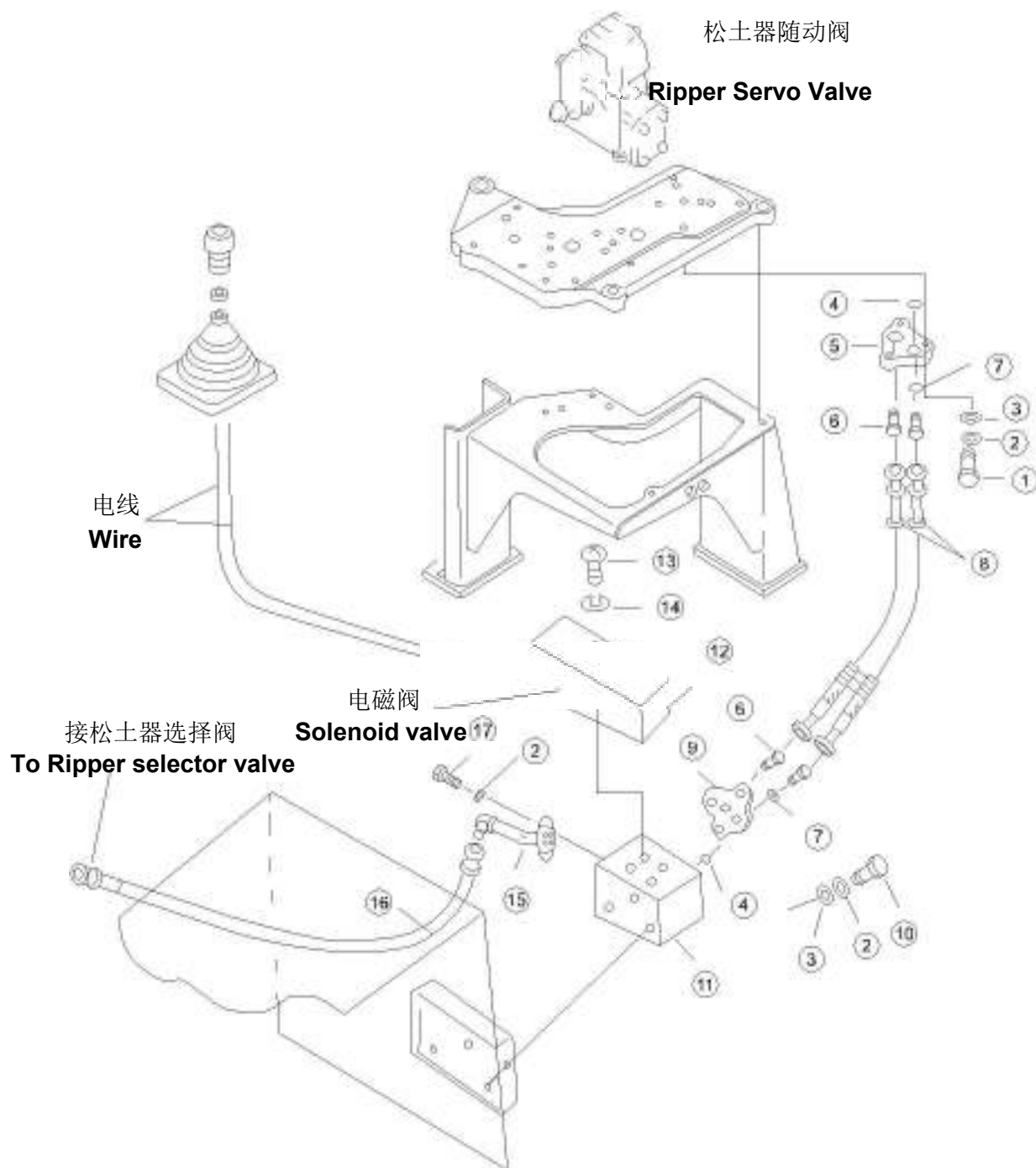

序号 NO.	部件号 PART NO.	零件名称 PART NAME		数量 Q'TY	适用机型 MODEL
1	01010-51035	螺栓 M10*35	Bolt M10*35	6	
2	01602-21030	垫圈 10	Washer 10	11	
3	01643-31032	垫圈 10	Washer 10	9	
4	07000-13022	O 形圈	O-ring	4	
5	23Y-89B-00001	法兰	Flange	1	
6	07230-20210	管接头	Nipple	4	
7	07005-01412	密封垫圈	Sealing gasket	4	
8	07102-20204	软管	Hose	2	
9	23Y-89B-00002	法兰	Flange	1	
10	01011-51005	螺栓 M10*105	Bolt M10*105	4	
11	171-86-04000	阀座	Valve seat	1	
12	171-86-05000	电磁阀	Solenoid valve	1	
13	01252-70640	螺钉 M6*40	Screw M6*40	4	
14	01602-20619	垫圈 6	Washer 6	4	
15	23Y-89-12100	接头	Nipple	2	
16	07102-20314	软管	Hose	1	
17	01010-51025	螺栓 M10*25	Bolt M10*25	2	

A series of horizontal dashed lines for writing notes.

工作装置

**WORK EQUIPMENT**

# 直倾铲 STRAIGHT TILT BLADE

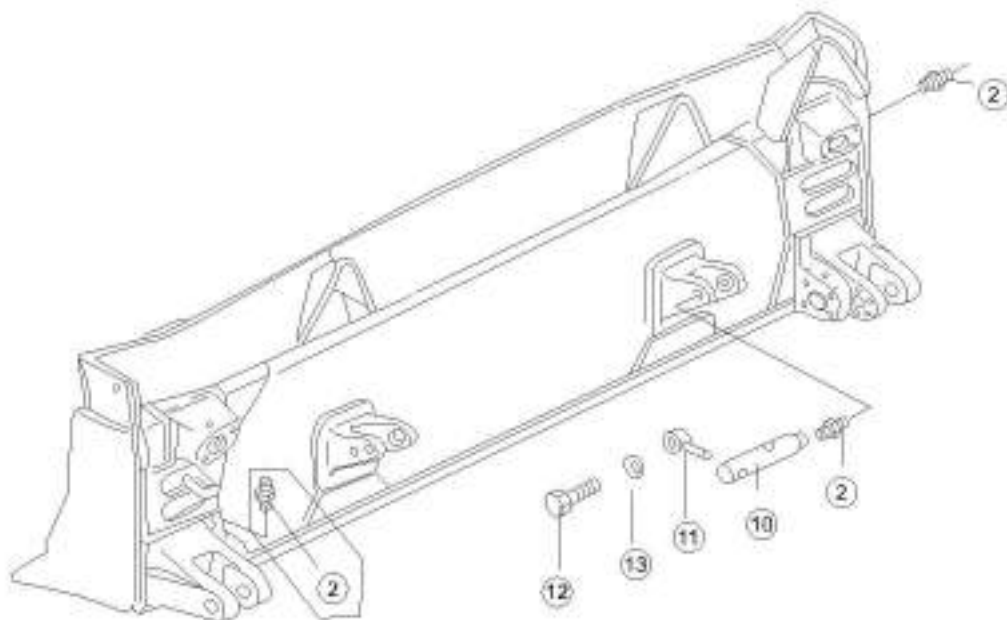
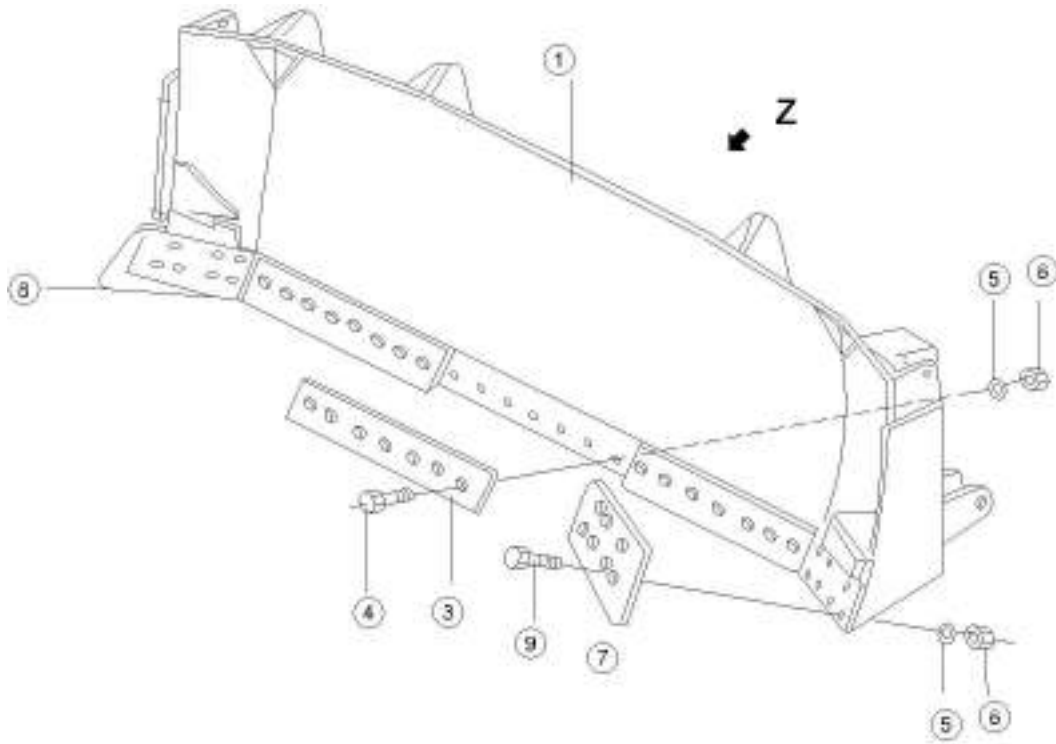

序号 NO.	部件号 PART NO.	零件名称 PART NAME		数量 Q'TY	适用机型 MODEL
1	175-71-31000	刀头总成	Blade ass'y	1	
2	07020-01021	油杯 M10*1	Oil cup M10*1	10	
3	175-70-26310	刀片	Cutting edge	3	
4	175-71-11454	螺栓	Bolt	21	
5	01643-52245	垫圈 22	Washer 22	35	
6	175-71-11530	螺帽	Nut	35	
7	175-71-22272	左刀角	Bit, End (L.H.)	1	
8	175-71-22282	右刀角	Bit, End (R.H.)	1	
9	175-71-11463	螺栓	Bolt	14	
10	175-71-11351	轴	Shaft	2	
11	195-71-11520	销	Pin	2	
12	01010-51435	螺栓 M14*35	Bolt M14*35	2	
13	01643-31445	垫圈 14	Washer 14	2	

# 直倾铲推杆 STRAIGHT TILT FRAME

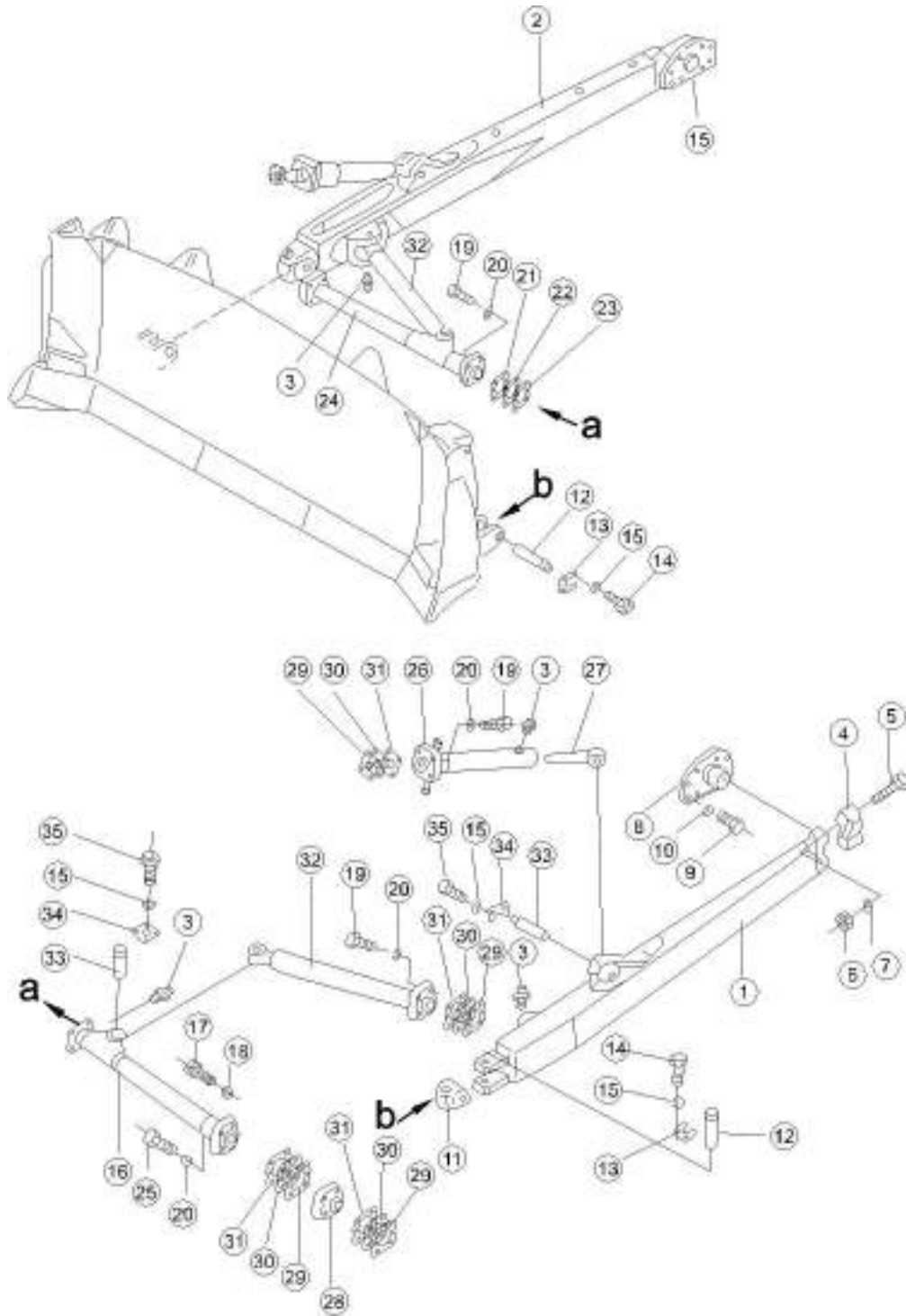

序号 NO.	部件号 PART NO.	零件名称 PART NAME		数量 Q'TY	适用机型 MODEL
1	175-71-31152	左推杆	Push rod (L.H.)	1	
2	175-71-31166	右推杆	Push rod (R.H.)	1	
3	07020-01021	油杯 M10*1	Oil cup M10*1	4	
4	175-71-11482	端盖	End cover	2	
5	175-71-11491	螺栓	Bolt	8	
6	175-71-11520	螺母	Nut	8	
7	01643-32260	垫圈 22	Washer 22	8	
8	175-70-23133	球接头	Ball Joint	2	
9	01010-52450	螺栓 M24*50	Bolt M24*50	16	
10	01643-32460	垫圈 24	Washer 24	16	
11	175-71-21261	接头	Nipple	2	
12	175-71-21221	销	Pin	4	
13	175-71-21230	锁板	Lock plate	4	
14	01010-51440	螺栓 M14*40	Bolt M14*40	16	
15	01643-31445	垫圈 14	Washer 14	32	
16	175-71-31183	左臂	Arm (L.H.)	1	
17	01010-51270	螺栓 M12*70	Bolt M12*70	4	
18	01643-31232	垫圈 12	Washer 12	4	
19	01011-82700	螺栓 M27*100	Bolt M27*100	20	
20	01643-32780	垫圈 27	Washer 27	28	
21	175-71-31390	垫片	Shim	4	
22	175-71-31410	垫片	Shim	8	
23	175-71-31420	垫片	Shim	4	
24	175-71-31233	右臂	Arm (R.H.)	1	
25	175-71-21351	螺栓	Bolt	8	
26	175-71-21272	支杆	Support bar	1	
27	175-71-11281	螺杆	Screw	1	
28	175-71-31280	端盖	End cover	2	
29	175-71-31250	垫片	Shim	32	
30	175-71-31260	垫片	Shim	56	
31	175-71-31270	垫片	Shim	48	
32	175-71-31293	支臂	Support	2	
33	154-71-21290	销	Pin	4	
34	175-71-21330	锁垫	Lock washer	4	
35	01010-51435	螺栓 M14*35	Bolt M14*35	16	

# 角铲 ANGLE BLADE

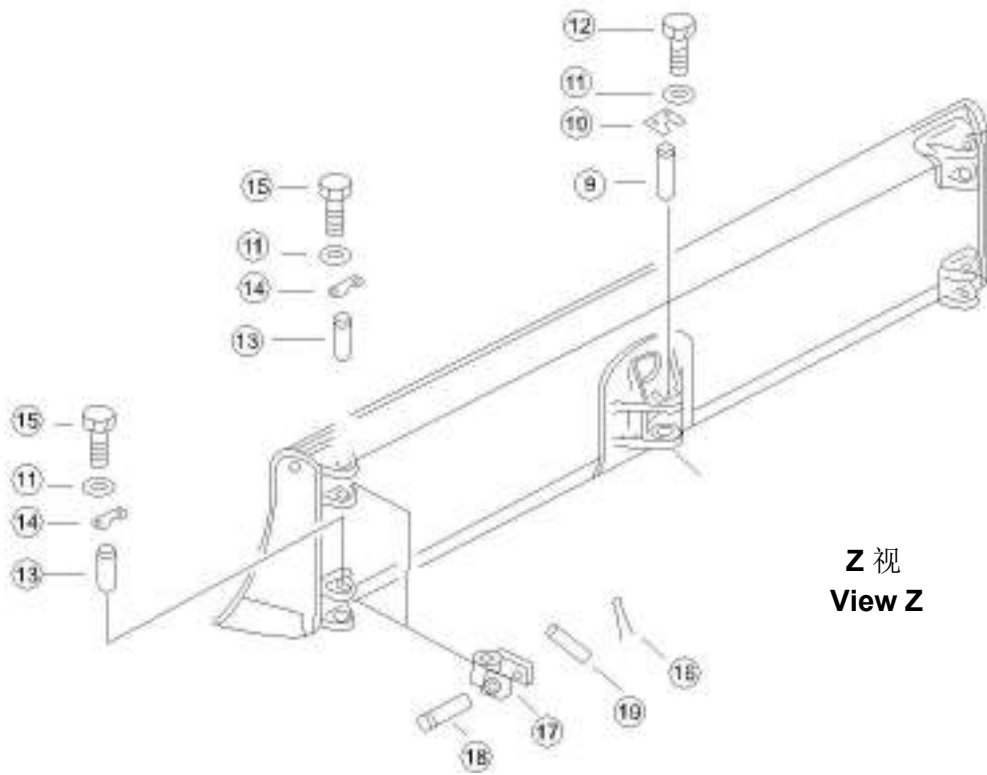
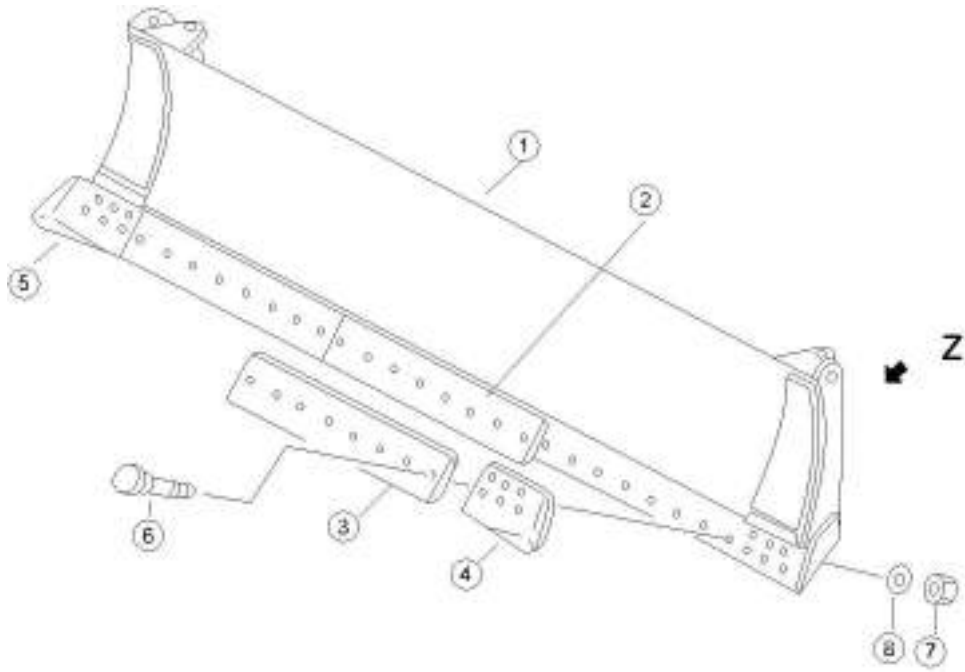

Z 视  
View Z

序号 NO.	部件号 PART NO.	零件名称 PART NAME		数量 Q'TY	适用机型 MODEL
1	24Y-81-01000	刀头	Blade	1	
2	175-70-26310	刀片	Edge, Cutting	1	
3	24Y-81-00006	刀片	Edge, Cutting	2	
4	24Y-81-00001	左刀角	Bit, End (L.H.)	1	
5	24Y-81-00002	右刀角	Bit, End (L.H.)	1	
6	175-71-11454	螺栓	Bolt	41	
7	175-71-11530	螺帽	Nut	41	
8	01643-52245	垫圈 22	Washer 22	39	
9	24Y-81-00010	轴销	Shaft pin	1	
10	09257-06009	锁紧垫	Lock washer	1	
11	01643-21445	垫圈	Washer	12	
12	01010-51435	螺栓 M14*35	Bolt M14*35	4	
13	24Y-81-00008	销	Pin	4	
14	24Y-81-00007	板	Plate	4	
15	01010-51430	螺栓 M14*30	Bolt M14*30	8	
16	04050-04026	开口销	Cotter pin	4	
17	24Y-81-02000	连节	Link	4	
18	24Y-81-00003	轴销	Shaft pin	4	
19	170-70-12240	插销	Pin	2	

# 弓形架 C-FRAME

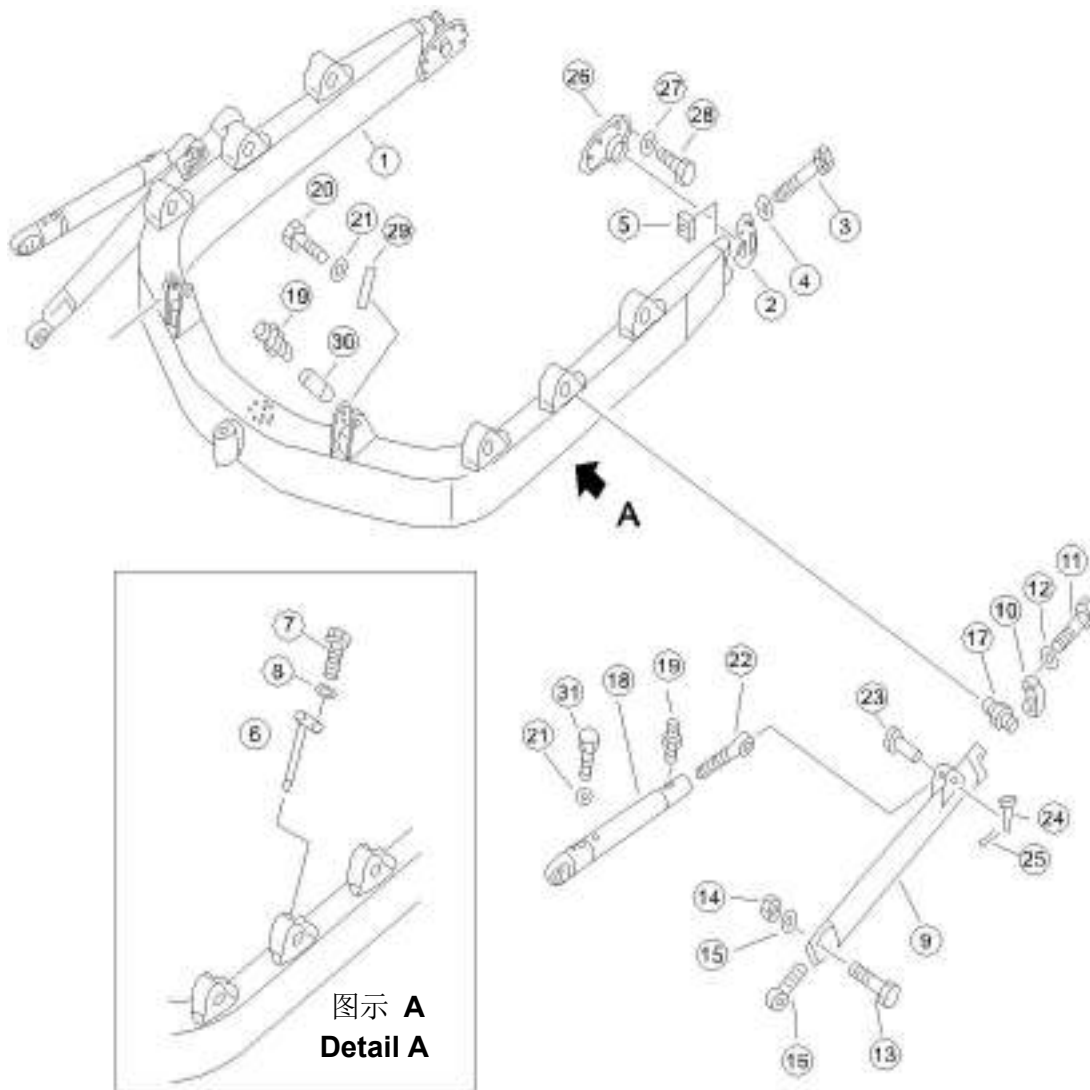

序号 NO.	部件号 PART NO.	零件名称 PART NAME		数量 Q'TY	适用机型 MODEL
1	24Y-81-05000	弓形架	C-Frame	1	
2	175-71-11482	端盖	End cover	2	
3	175-71-11491	螺栓	Bolt	8	
4	01643-52245	垫圈 22	Washer 22	8	
5	01580-12218	螺母 M22	Nut M22	8	
6	154-70-19181	插销	Pin	2	
7	01010-51430	螺栓 M14*30	Bolt M14*30	2	
8	205-06-62270	垫圈	Washer	2	
9	24Y-81-03000	撑杆	Support rod	2	
10	175-70-12160	轴盖	Shaft cover	2	
11	01010-52095	螺栓 M20*95	Bolt M20*95	8	
12	01643-32060	垫圈 20	Washer 20	8	
13	01010-51870	螺栓 M18*70	Bolt M18*70	4	
14	01580-11815	螺母 M18	Nut M18	4	
15	01643-51845	垫圈 18	Washer 18	4	
16	175-70-12130	螺杆	Screw	2	
17	24Y-81-00005	球接头	Ball Joint	2	
18	24Y-81-04000	撑杆	Support rod	2	
19	07020-01021	油杯 M10*1	Oil cup M10*1	4	
20	01010-51435	螺栓 M14*35	Bolt M14*35	2	
21	01643-21445	垫圈	Washer	4	
22	24Y-81-00004	螺杆	Screw	2	
23	150-70-13411	插销	Pin	2	
24	170-70-12240	插销	Pin	2	
25	04050-04026	开口销	Cotter pin	2	
26	175-70-23133	球接头	Ball Joint	2	
27	01643-32460	垫圈 24	Washer 24	16	
28	01010-52450	螺栓 M24*50	Bolt M24*50	16	
29	195-71-11520	销	Pin	2	
30	175-71-11351	轴	Shaft	2	
31	24Y-81-00011	锁止螺栓	Lock bolt	2	

# 半 U 形铲 SEMI-U BLADE

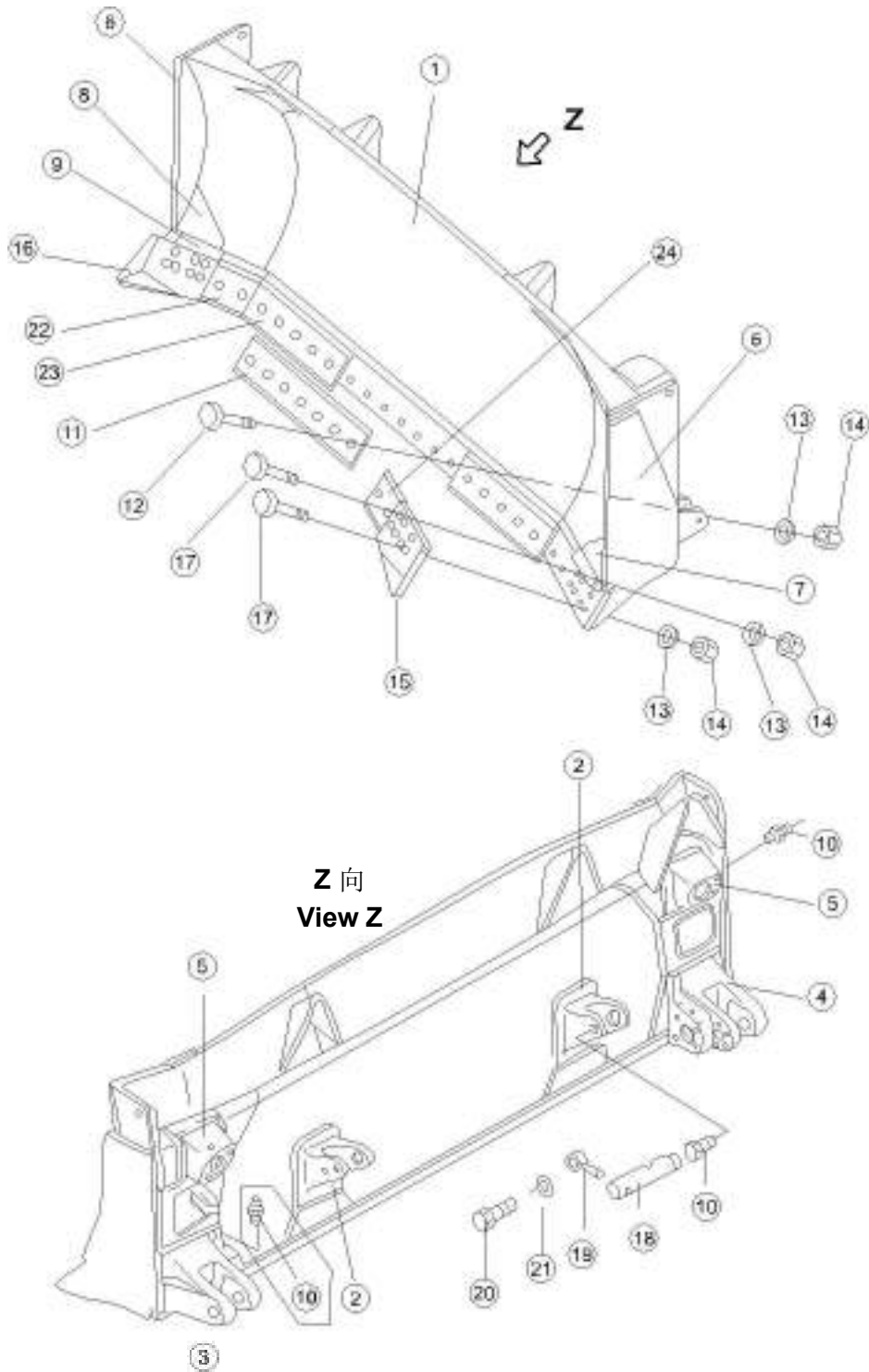

序号 NO.	部件号 PART NO.	零件名称 PART NAME	数量 Q'TY	适用机型 MODEL
1	171-82-01000	半 U 形铲刀头 Semi-U blade	1	
2	175-71-27842A	托架 Bracket	2	
3	175-71-31121	左托架 L.H. Bracket	1	
4	175-71-31131	右托架 R.H. Bracket	1	
5	175-71-31141	支座 Seat	2	
6	171-82-01122	板 Plate	2	
7	175-71-22350	左板 Plate (L.H.)	1	
8	175-71-22360	右板 Plate (R.H.)	1	
9	175-71-22340	限位块 Limit stop	2	
10	07020-01021	油杯 M10*1 Oil cup M10*1	6	
11	175-71-26310	刀片 Edge, Cutting	1	
12	175-71-11454	螺栓 Bolt	17	
13	01643-52245	垫圈 22 Washer 22	35	
14	175-71-11530	螺帽 Nut	35	
15	175-71-22272	左刀角 Bit, End (L.H.)	1	
16	175-71-22282	右刀角 Bit, End (L.H.)	1	
17	175-71-11463	螺栓 Bolt	18	
18	175-71-11351	轴 Shaft	2	
19	195-71-11520	销 Pin	2	
20	01010-51435	螺栓 M14*35 Bolt M14*35	2	
21	01643-31445	垫圈 14 Washer 14	2	
22	171-82-00003	刀片 Edge, Cutting	1	
23	171-82-00002	刀片 Edge, Cutting	2	
24	171-82-00001	刀片 Edge, Cutting	1	

# 半 U 形铲推杆 SEMI-U BLADE FRAME

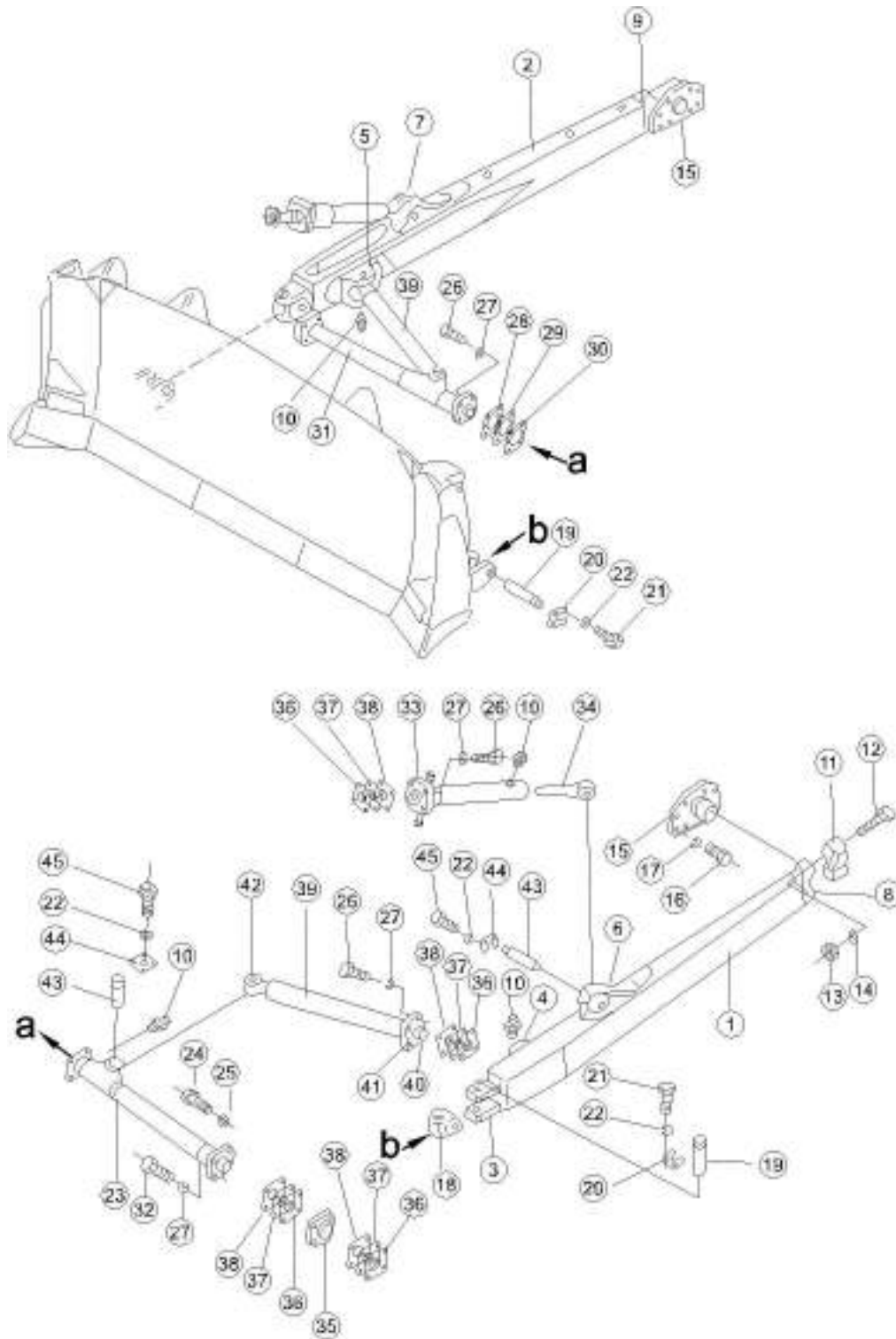

序号 NO.	部件号 PART NO.	零件名称 PART NAME		数量 Q'TY	适用机型 MODEL
1	175-71-31152	左推杆	Push rod (L.H.)	1	
2	175-71-31166	右推杆	Push rod (R.H.)	1	
3	175-71-21182	支架	Bracket	2	
4	175-71-31173	左支架	Bracket (L.H.)	1	
5	175-71-31622	右支架	Bracket (R.H.)	1	
6	175-71-31650	左托架	L.H. Bracket	1	
7	175-71-31660	右托架	R.H. Bracket	1	
8	175-71-11272	轴承座	Bearing support	1	
9	175-71-31311	托架	Bracket	1	
10	07020-01021	油杯 M10*1	Oil cup M10*1	4	
11	175-71-11482	端盖	End cover	2	
12	175-71-11491	螺栓	Bolt	8	
13	175-71-11520	螺母	Nut	8	
14	01643-32260	垫圈 22	Washer 22	8	
15	175-70-23133	球接头	Ball Joint	2	
16	01010-52450	螺栓 M24*50	Bolt M24*50	16	
17	01643-32460	垫圈 24	Washer 24	16	
18	175-71-21261	接头	Nipple	2	
19	175-71-21221	销	Pin	4	
20	175-71-21230	锁板	Lock plate	4	
21	01010-51440	螺栓 M14*40	Bolt M14*40	16	
22	01643-31445	垫圈 14	Washer 14	32	
23	175-71-31183	左臂	Arm (L.H.)	1	
24	01010-51270	螺栓 M12*70	Bolt M12*70	4	
25	01643-31232	垫圈 12	Washer 12	4	
26	01011-82700	螺栓 M27*100	Bolt M27*100	20	
27	01643-32780	垫圈 27	Washer 27	28	
28	175-71-31390	垫片	Shim	4	
29	175-71-31410	垫片	Shim	8	
30	175-71-31420	垫片	Shim	4	
31	175-71-31233	右臂	Arm (R.H.)	1	
32	175-71-21351	螺栓	Bolt	8	

# 半 U 形铲推杆 SEMI-U BLADE FRAME

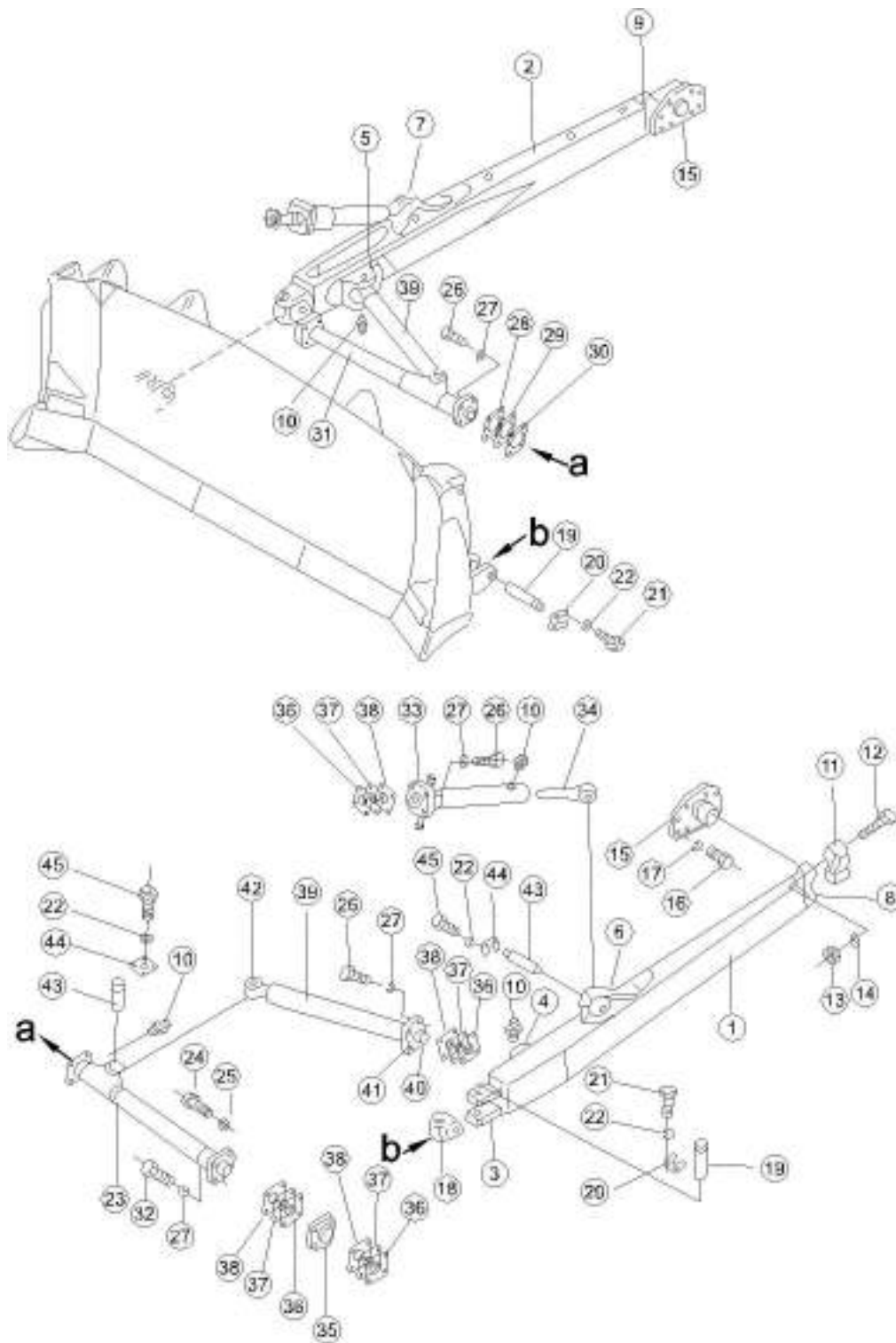

序号 NO.	部件号 PART NO.	零件名称 PART NAME		数量 Q'TY	适用机型 MODEL
33	175-71-21272	支杆	Support bar	1	
34	175-71-11281	螺杆	Screw	1	
35	175-71-31280	端盖	End cover	2	
36	175-71-31250	垫片	Shim	32	
37	175-71-31260	垫片	Shim	56	
38	175-71-31270	垫片	Shim	48	
39	175-71-31293	支臂	Support	2	
40	175-71-31562	球接头	Ball Joint	2	
41	175-71-31190	端盖	End cover	2	
42	195-71-22681	接头	Nipple	2	
43	154-71-21290	销	Pin	4	
44	175-71-21330	锁垫	Lock washer	4	
45	01010-51435	螺栓 M14*35	Bolt M14*35	16	

# 牵引装置 TRACTION DEVICE

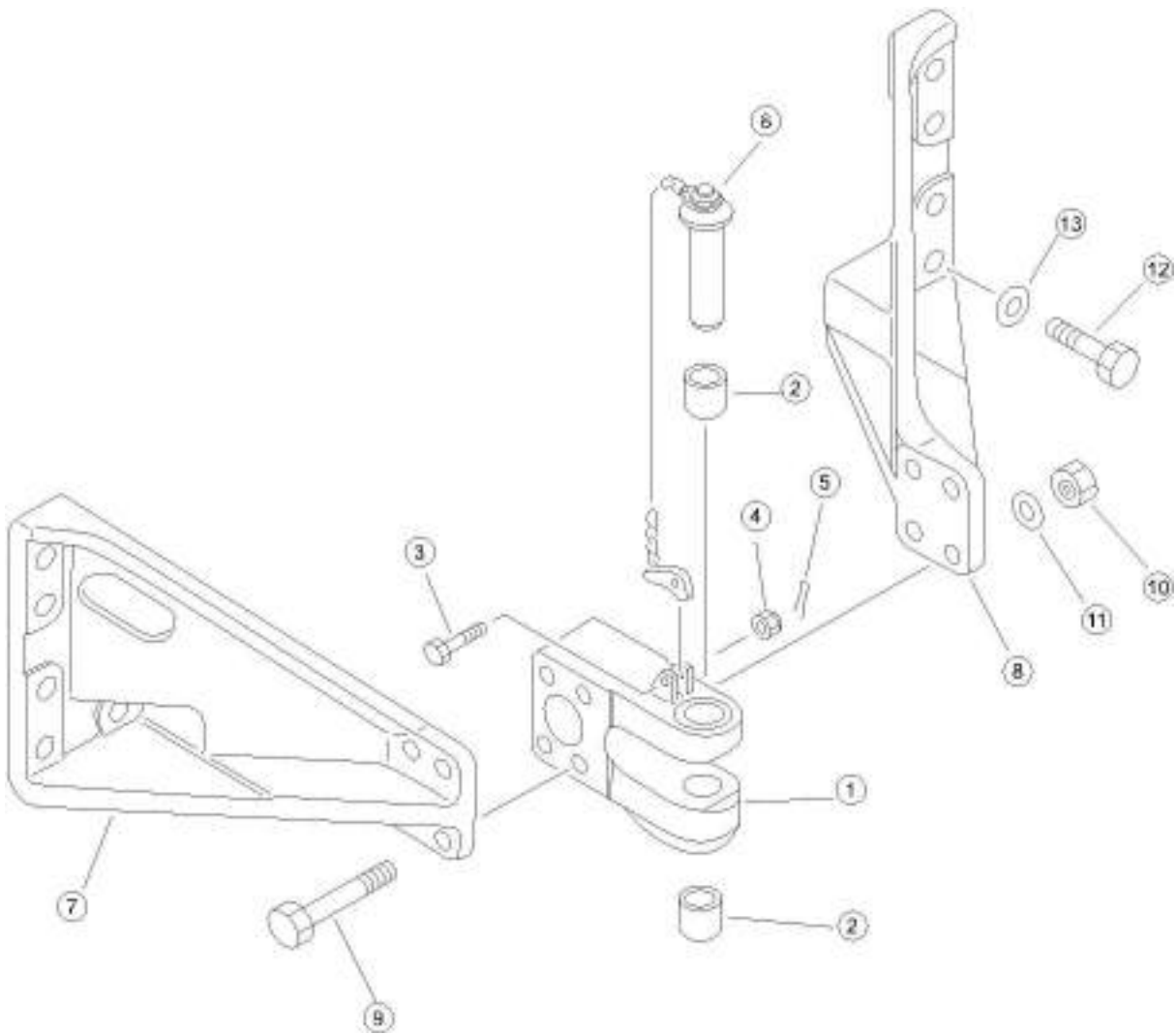

序号 NO.	部件号 PART NO.	零件名称 PART NAME		数量 Q'TY	适用机型 MODEL
1	175-69-21212	挂钩座	Seat, Hook	1	
2	195-69-11230	衬套	Bushing	2	
3	01052-51675	螺栓 M16*1.5*75	Bolt M16*1.5*75	1	
4	01592-11619	螺母 M16*1.5	Nut M16*1.5	1	
5	04050-14030	开口销	Cotter pin	1	
6	195-69-11223	销子总成	Pin ass'y	1	
7	175-69-21111	左牵引架	Traction frame (L.H.)	1	
8	175-69-21121	右牵引架	Traction frame (R.H.)	1	
9	170-69-11143	螺栓	Bolt	4	
10	01580-03326	螺母 M33*3	Nut M33*3	4	
11	01643-33380	垫圈 33	Washer 33	4	
12	01018-33990	螺栓 M39*3*90	Bolt M39*3*90	10	
13	195-69-11140	垫圈	Washer	10	

### 三齿松土器总成 TRIPLE-SHANK RIPPLER ASS'Y

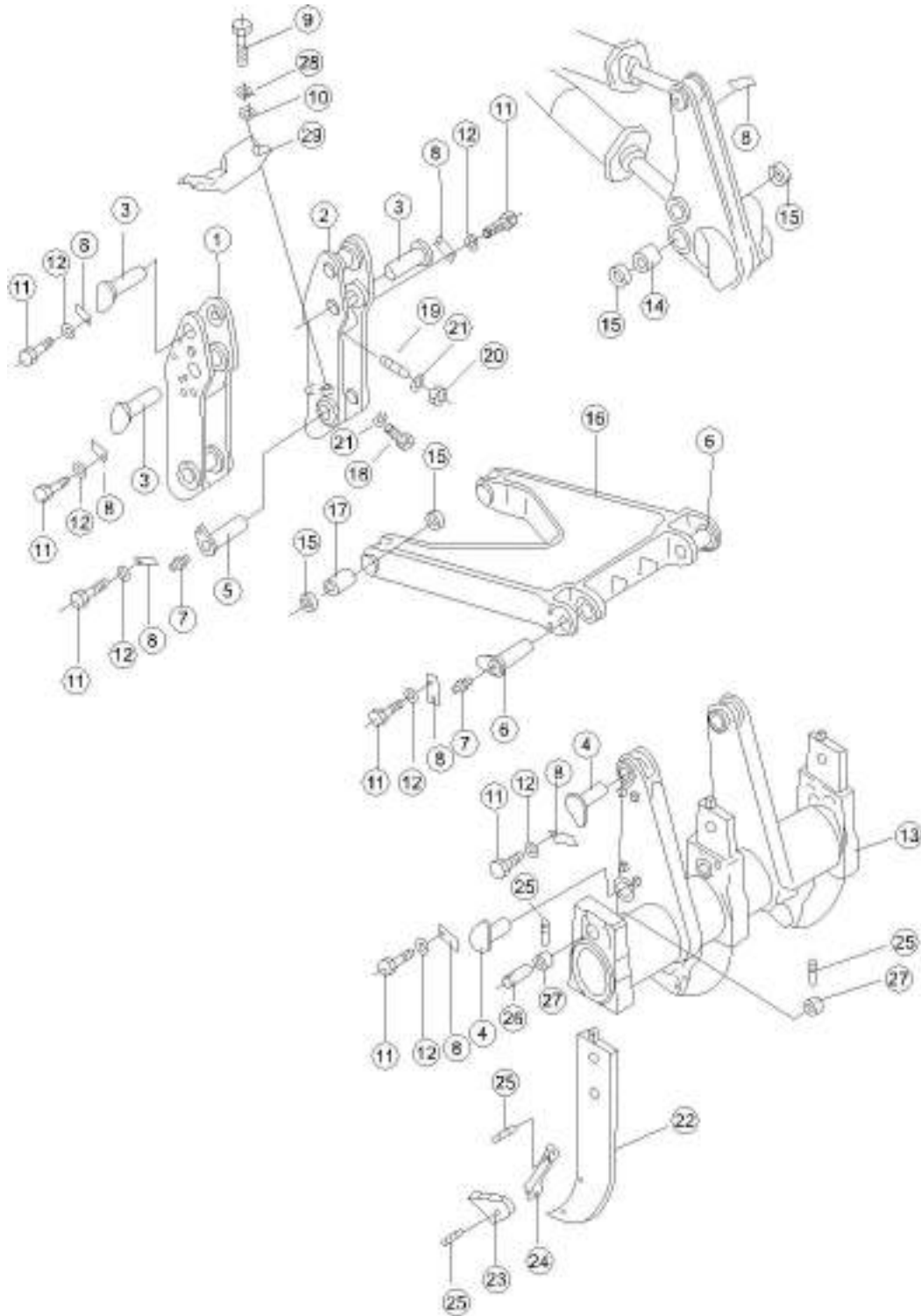

序号 NO.	部件号 PART NO.	零件名称 PART NAME		数量 Q'TY	适用机型 MODEL
1	175-78-61113	左托架	L.H. Bracket	1	
2	175-78-61124	右托架	R.H. Bracket	1	
3	175-78-61151	销	Pin	4	
4	175-78-61181	销	Pin	4	
5	175-78-61161	销	Pin	2	
6	175-78-61171	销	Pin	2	
7	07020-01021	油杯 M10*1	Oil cup M10*1	4	
8	195-78-21171	板	Plate	12	
9	01010-51645	螺栓 M16*45	Bolt M16*45	4	
10	01643-21645	垫圈	Washer	4	
11	01010-52040	螺栓 M20*40	Bolt M20*40	25	
12	01643-32060	垫圈 20	Washer 20	25	
13	175-78-61141	横梁	Cross beam	1	
14	175-78-61271	轴瓦	Bushing	2	
15	175-78-61281	密封圈	Seal ring	8	
16	175-78-61132	连接架	Connecting frame	1	
17	175-78-61261	轴瓦	Bushing	2	
18	01018-33990	螺栓 M39*3*90	Bolt M39*3*90	10	
19	195-78-11270	双头螺栓	Studs	4	
20	195-69-11131	螺母	Nut	4	
21	195-69-11140	垫圈	Washer	14	
22	175-78-21615	松土支角	Ripper shank	3	
23	175-78-31230	齿尖	Tooth tip	3	
24	195-78-21320	保护器	Holder	3	
25	175-78-21740	销套	Bushing	15	
26	175-78-61331	销	Pin	3	
27	175-78-61341	环	Ring	6	
28	01602-21648	垫圈 16	Washer 16	4	
29	175-78-61320	防护板	Guard plate	1	

# 单齿松土器总成 SINGLE-SHANK RIPPER ASS'Y

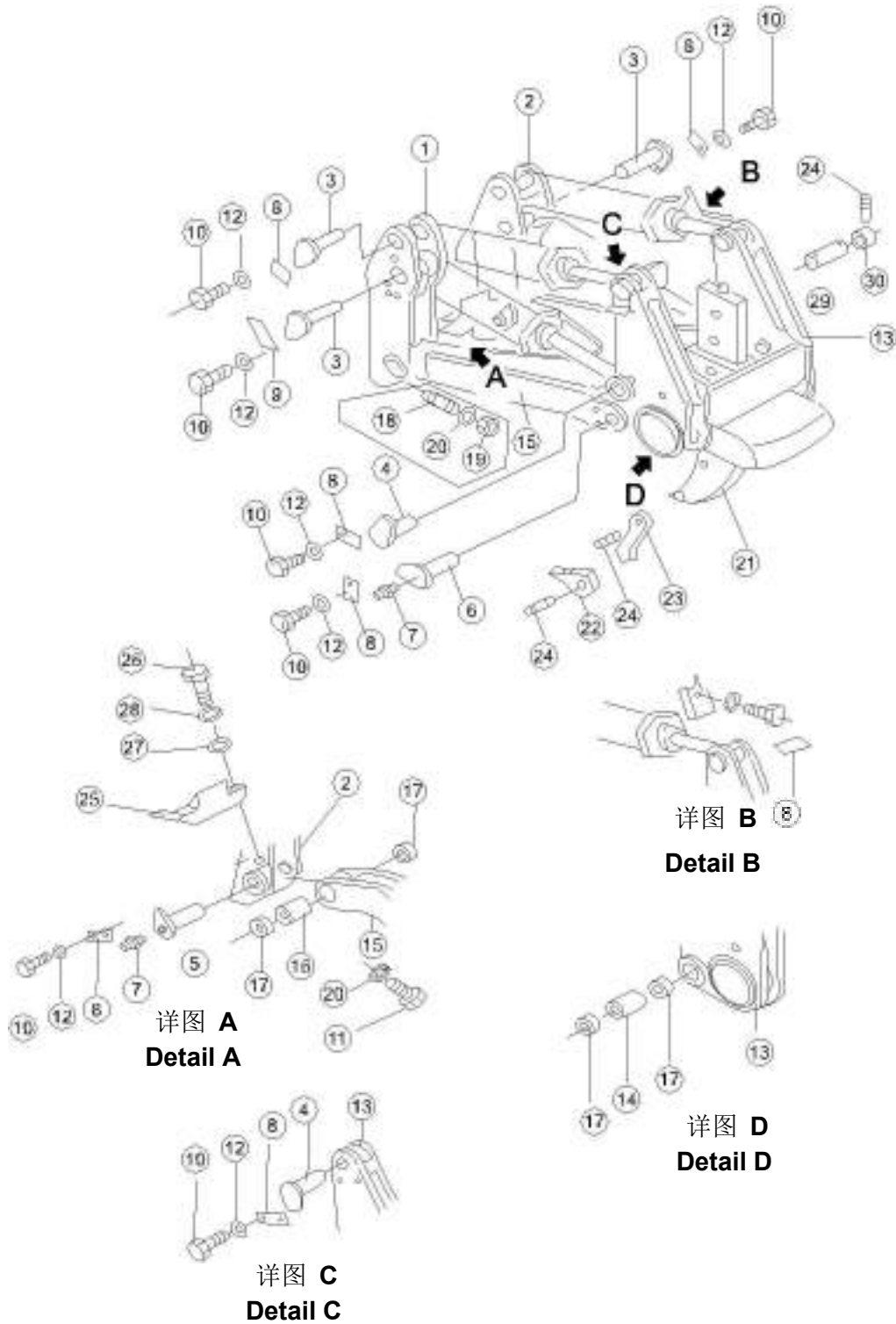

序号 NO.	部件号 PART NO.	零件名称 PART NAME		数量 Q'TY	适用机型 MODEL
1	175-78-61113	左托架	Bracket (L.H.)	1	
2	175-78-61124	右托架	Bracket (R.H.)	1	
3	175-78-61151	销	Pin	4	
4	175-78-61181	销	Pin	4	
5	175-78-61161	销	Pin	2	
6	175-78-61171	销	Pin	2	
7	07020-01021	油杯 M10*1	Oil cup M10*1	4	
8	195-78-21171	板	Plate	11	
9	24Y-89-10000	板	Plate	1	
10	01010-52045	螺栓 M20*45	Bolt M20*45	25	
11	01018-33990	螺栓 M39*3*90	Bolt M39*3*90	10	
12	01643-32060	垫圈 20	Washer 20	25	
13	24Y-89-20000	横梁	Cross beam	1	
14	175-78-61271	轴瓦	Bushing	2	
15	175-78-61132	连接架	Connecting frame	1	
16	175-78-61261	轴瓦	Bushing	2	
17	175-78-61281	密封圈	Seal ring	8	
18	195-78-11270	双头螺栓	Studs	4	
19	195-69-11131	螺母	Nut	4	
20	195-69-11140	垫圈	Washer	14	
21	24Y-89-30000	齿杆	Tooth lever	1	
22	175-78-31230	齿尖	Tooth tip	1	
23	195-78-21320	保护器	Holder	1	
24	175-78-21740	销套	Bushing	5	
25	175-78-61320	防护板	Guard plate	1	
26	01010-51640	螺栓 M16*40	Bolt M16*40	4	
27	01643-31645	垫圈 16	Washer 16	4	
28	01602-21648	垫圈 16	Washer 16	4	
29	24Y-89-00001	销	Pin	1	
30	24Y-89-00002	环	Ring	2	



电气系统 (不装 **GPS**)

**ELECTRICAL SYSTEM (WITHOUT GPS)**

# 电气系统 (1/2) ELECTRICAL SYSTEM (1/2)

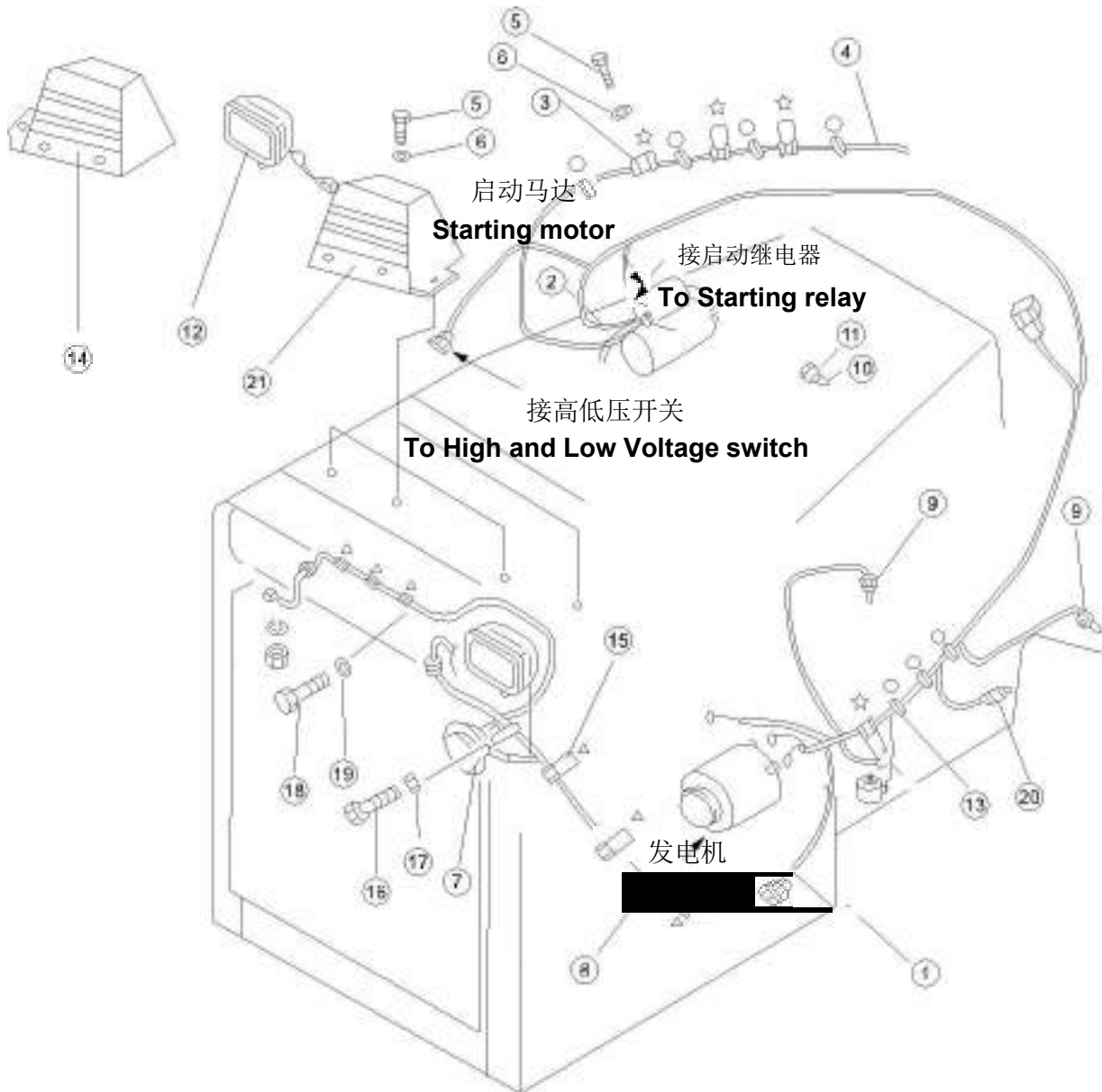

零件图册 | 电气系统 (不装 GPS)

序号 NO.	部件号 PART NO.	零件名称 PART NAME		数量 Q'TY	适用机型 MODEL
1	171-07-03000	发动机线束	Engine wiring harness	1	
2	23Y-07B-08000	启动机搭铁线	Starter's bond strap	1	
3	08035-12510	线夹	Wire clip	4	
4	171-07-01000	电缆	Cable	1	
5	01010-51016	螺栓 M10*16	Bolt M10*16	6	
6	01643-31032	垫圈 10	Washer 10	6	
7	D2711-10500	喇叭	Horn	1	
8	171-07-04000	前灯线束	Headlight wiring harness	1	
9	D2320-15000	油温传感器	Oil temperature sensor	2	
10	23Y-07E-00003	接头	Nipple	1	
11	D2160-00800	空气滤清器保养指示器	Air filter indicator	1	
12	D2401-07000	工作灯	Working lamp	2	
13	08034-20519	箍	Clamp	7	
14	23Y-07B-13000	灯罩 ( 右 )	Lamp cover (R.H.)	1	
15	08035-11014	线夹	Wire clip	6	
16	01010-50816	螺栓 M8*16	Bolt M8*16	1	
17	01643-30823	垫圈 8	Washer 8	1	
18	01010-51216	螺栓 M12*16	Bolt M12*16	6	
19	01643-31232	垫圈 12	Washer 12	6	
20	D2300-00700	压力传感器	Pressure sensor	1	
21	23Y-07B-12000	灯罩 ( 左 )	Lamp cover (L.H.)	1	

# 电气系统 (2/2) ELECTRICAL SYSTEM (2/2)

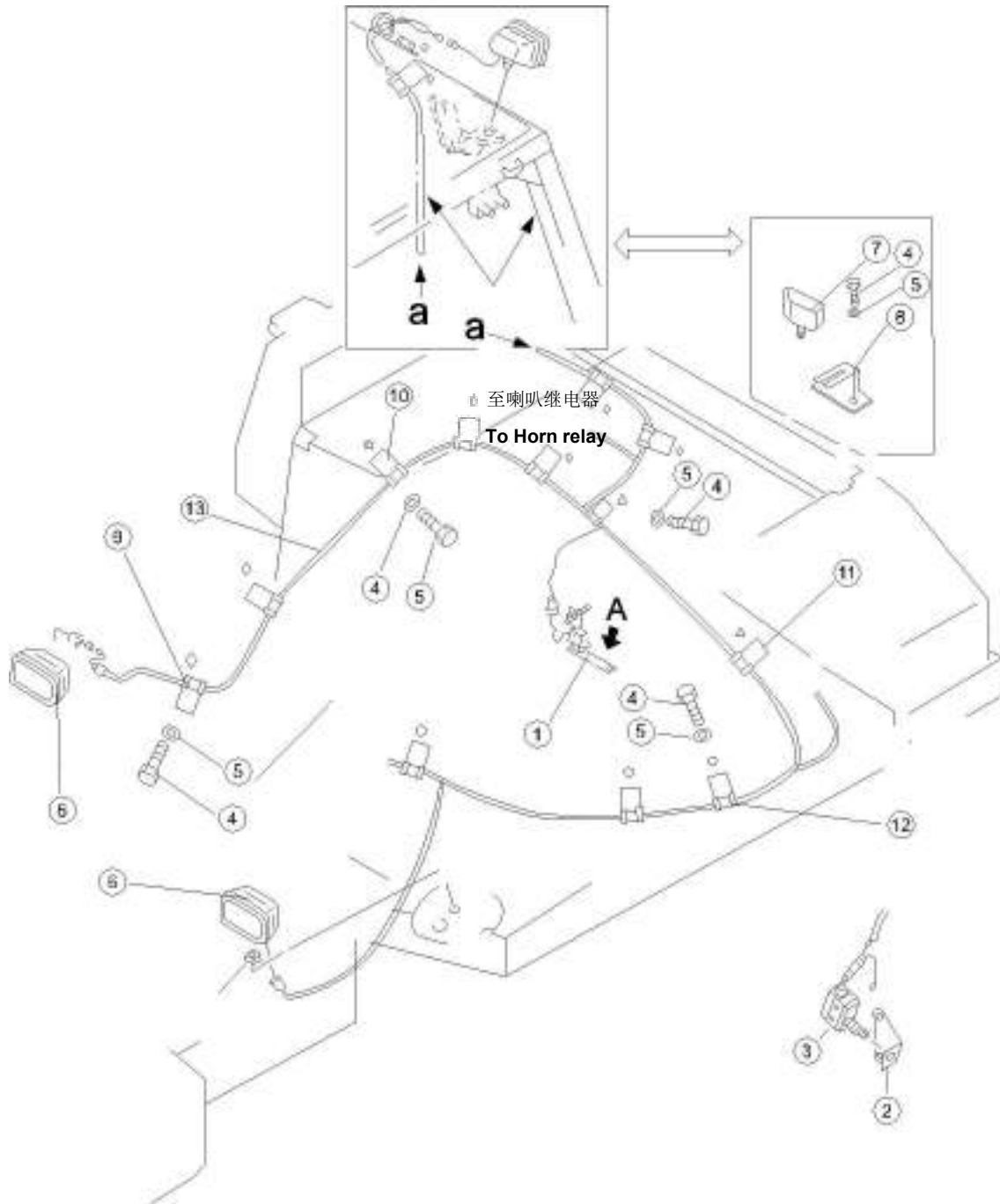

零件图册 | 电气系统 (不装 GPS)

序号 NO.	部件号 PART NO.	零件名称 PART NAME	数量 Q'TY	适用机型 MODEL
1	175-06-38561	支架 Bracket	1	
2	175-06-38810	支架 Bracket	1	
3	D2590-00820	行程开关 Stroke switch	1	
4	01010-51016	螺栓 M10*16 Bolt M10*16	14	
5	01643-31032	垫圈 10 Washer 10	14	
6	D2401-07040	灯 Lamp	2	
7	D2401-07000	工作灯 Working lamp	1	
8	16Y-07C-00008	支架 Bracket	1	
9	08035-11010	线夹 Wire clip	8	
10	08035-12510	线夹 Wire clip	1	
11	08035-11510	线夹 Wire clip	2	
12	08035-12010	线夹 Wire clip	3	
13	171-07-02000	地板架线束 Floor frame wiring harness	1	

# 仪表箱 METER BOX

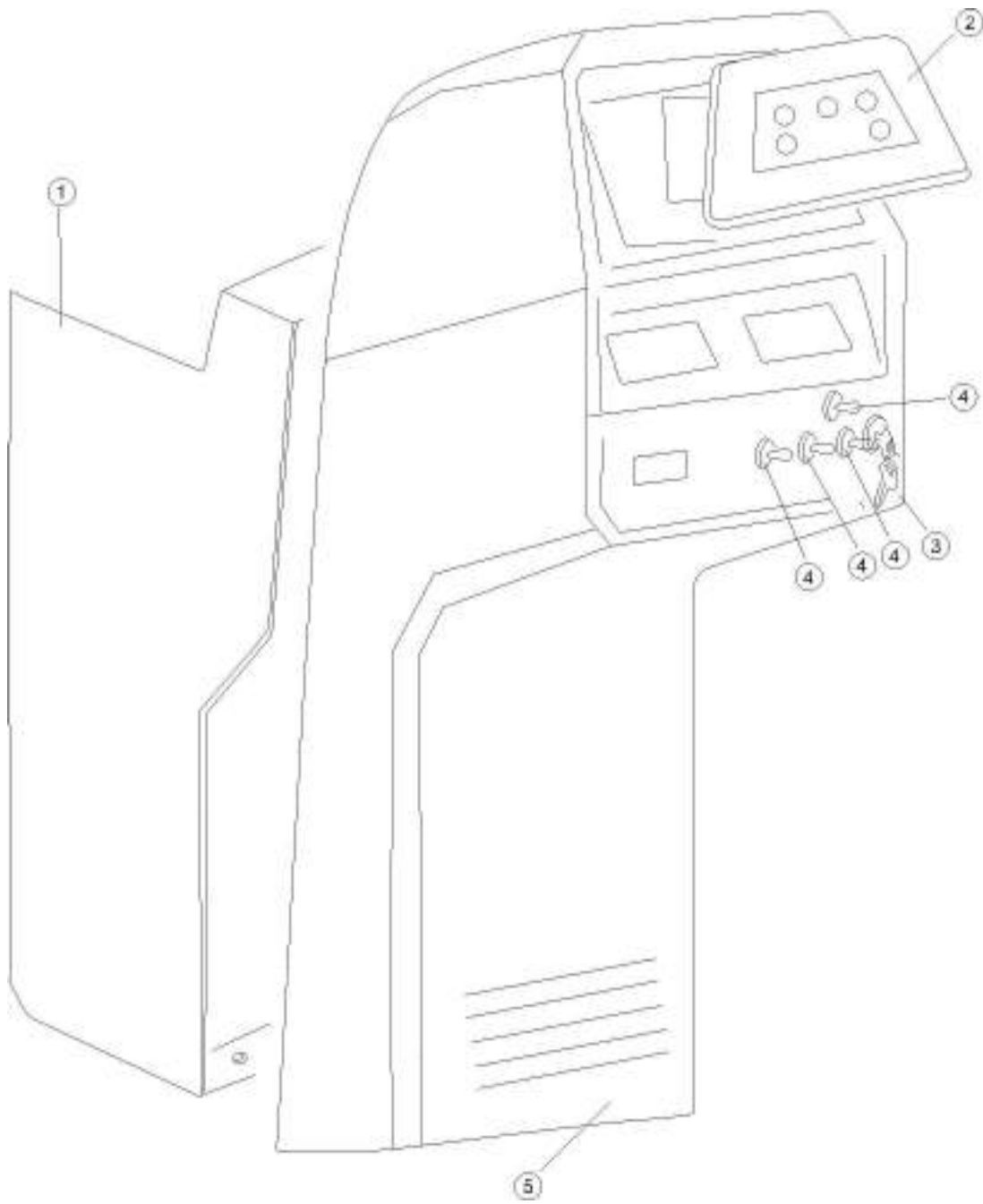

零件图册 | 电气系统 (不装 GPS)

序号 NO.	部件号 PART NO.	零件名称 PART NAME		数量 Q'TY	适用机型 MODEL
1	171-07-07000	箱体	Box body	1	
2	D2210-00000	组合仪表 (VDO)	Combination meter (VOD)	1	
3	D2500-00000	启动开关	Start switch	1	
4	D2530-01500	开关	Switch	4	
5	23Y-91B-01000	仪表台	Meter platform	1	

## 继电器与保险丝盒 RELAY AND FUSE BOX

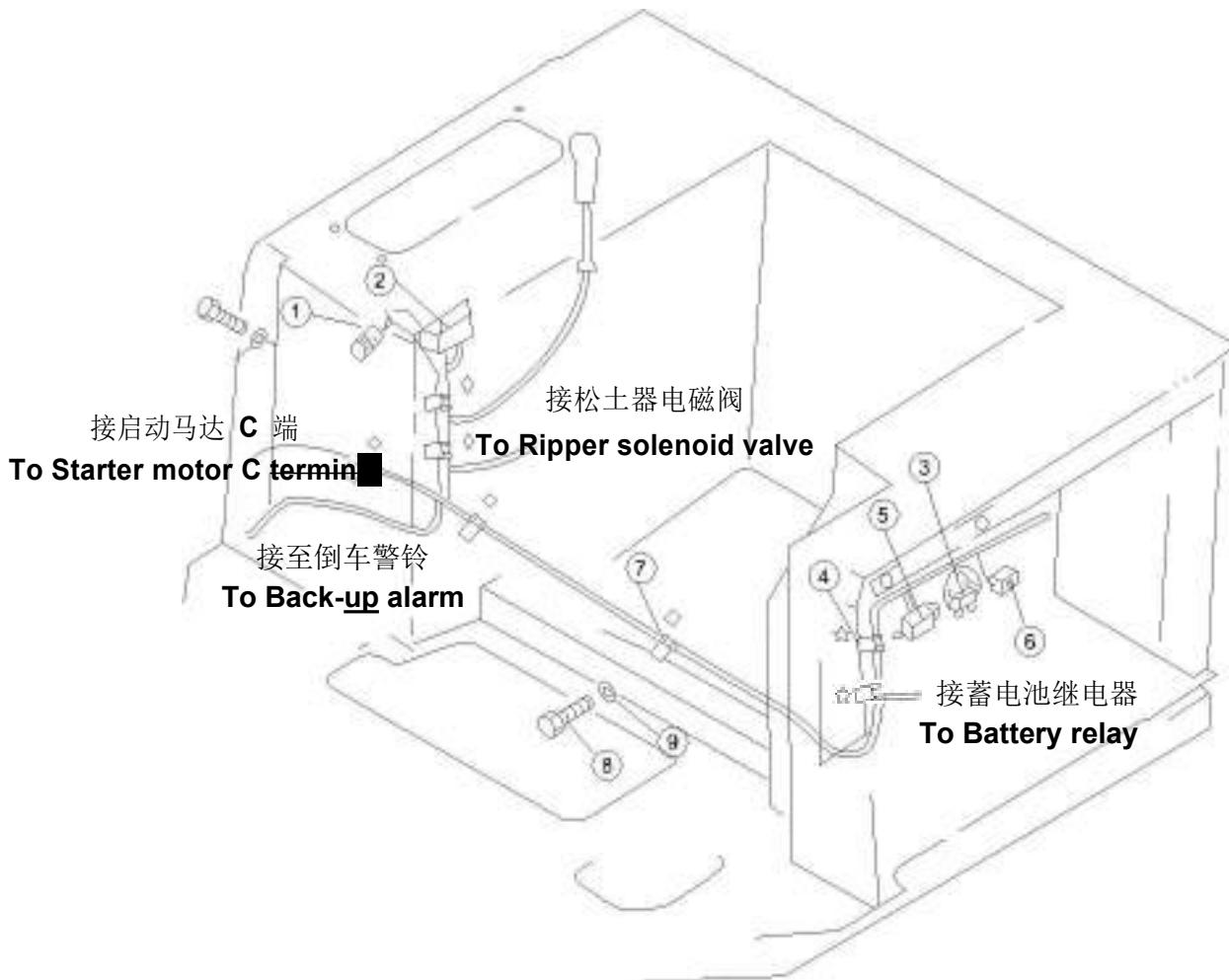

零件图册 | 电气系统 (不装 GPS)

序号 NO.	部件号 PART NO.	零件名称 PART NAME		数量 Q'TY	适用机型 MODEL
1	D2510-00600	喇叭开关	Horn switch	1	
2	D2650-01100	喇叭继电器	Horn relay	1	
3	D1620-00000	电压继电器	Voltage relay	1	
4	08035-12010	线夹	Wire clip	2	
5	D2763-00900	保险丝盒	Fuse box	1	
6	D2660-02000	通用继电器	Universal Relay	1	
7	08035-11510	线夹	Wire clip	5	
8	01010-51016	螺栓 M10*16	Bolt M10*16	7	
9	01643-31032	垫圈 10	Washer 10	7	

# 蓄电池与继电器 BATTERY AND RELAY

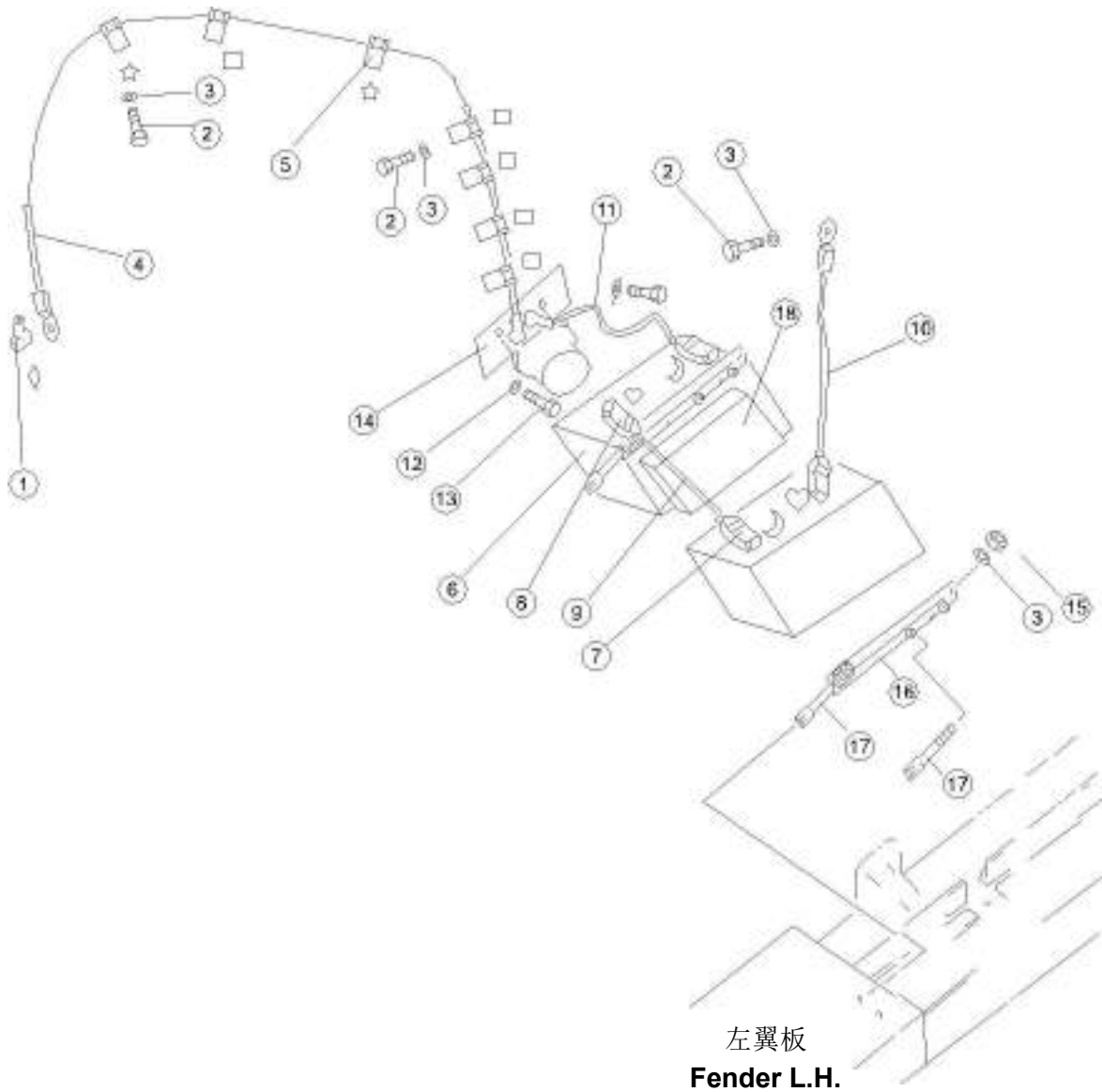

零件图册 | 电气系统 (不装 GPS)

序号 NO.	部件号 PART NO.	零件名称 PART NAME	数量 Q'TY	适用机型 MODEL
1	08038-00035	罩 Cover	3	
2	01010-51016	螺栓 M10*16 Bolt M10*16	8	
3	01643-31032	垫圈 10 Washer 10	12	
4	171-07-01000	电缆 Cable	1	
5	08035-12510	线夹 Wire clip	2	
6	D1011-07500	电池 Battery	2	
7	D2000-00000	绝缘套 Insulating sleeve	2	
8	D2000-00001	绝缘套 Insulating sleeve	2	
9	171-07-13000	电缆 ( 蓄电池 + 至蓄电 池 - ) Cable (Battery+ To Battery-) Cable (Battery negative	1	
10	171-07-14000	电缆( 蓄电池负极- 搭铁) - Bond strapping)	1	
11	171-07-15000	电缆 ( 蓄电池 +- 继电器 ) Cable (Battery+-Relay)	1	
12	01643-30823	垫圈 8 Washer 8	2	
13	01010-50825	螺栓 M8*25 Bolt M8*25	2	
14	D2610-60000	蓄电池继电器 Battery relay	1	
15	01580-11008	螺母 M10 Nut M10	8	
16	121-07-16000	压板 Binder plate	2	
17	175-06-39621	拉杆 Lever	4	
18	171-07-00001	垫 Pad	1	

# 驾驶室电气 CAB ELECTRIC

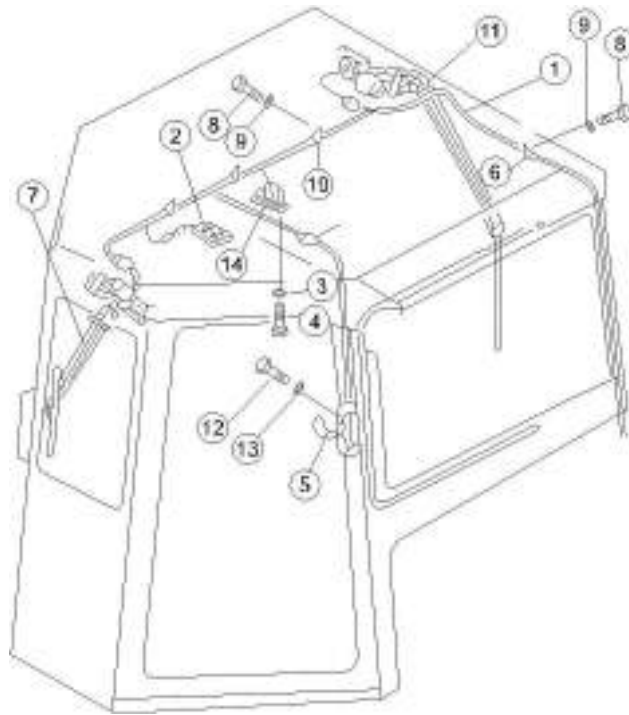

零件图册 | 电气系统 (不装 GPS)

序号 NO.	部件号 PART NO.	零件名称 PART NAME		数量 Q'TY	适用机型 MODEL
1	171-08-01000	驾驶室线束	Cab wiring harness	1	
2	D2430-01000	室内灯	Interior lamp	1	
3	01643-30823	垫圈 8	Washer 8	2	
4	01220-40820	螺钉 M8*20	Screw M8*20	2	
5	D2830-42500	风扇	Fan	1	
6	08035-11010	线夹	Wire clip	6	
7	D2801-05030	刮雨器	Wiper	1	
8	01010-51016	螺栓 M10*16	Bolt M10*16	4	
9	01643-31032	垫圈 10	Washer 10	4	
10	08035-11510	线夹	Wire clip	3	
11	D2801-09510	刮雨器	Wiper	1	
12	01252-70620	螺钉 M6*20	Screw M6*20	4	
13	01643-30623	垫圈 6	Washer 6	4	
14	171-08-00001	板	Plate	1	

A series of horizontal dashed lines for writing notes.

电气系统 (装 **GPS**)  
**ELECTRICAL SYSTEM (WITH GPS)**

# 电气系统 (1/2) ELECTRICAL SYSTEM (1/2)

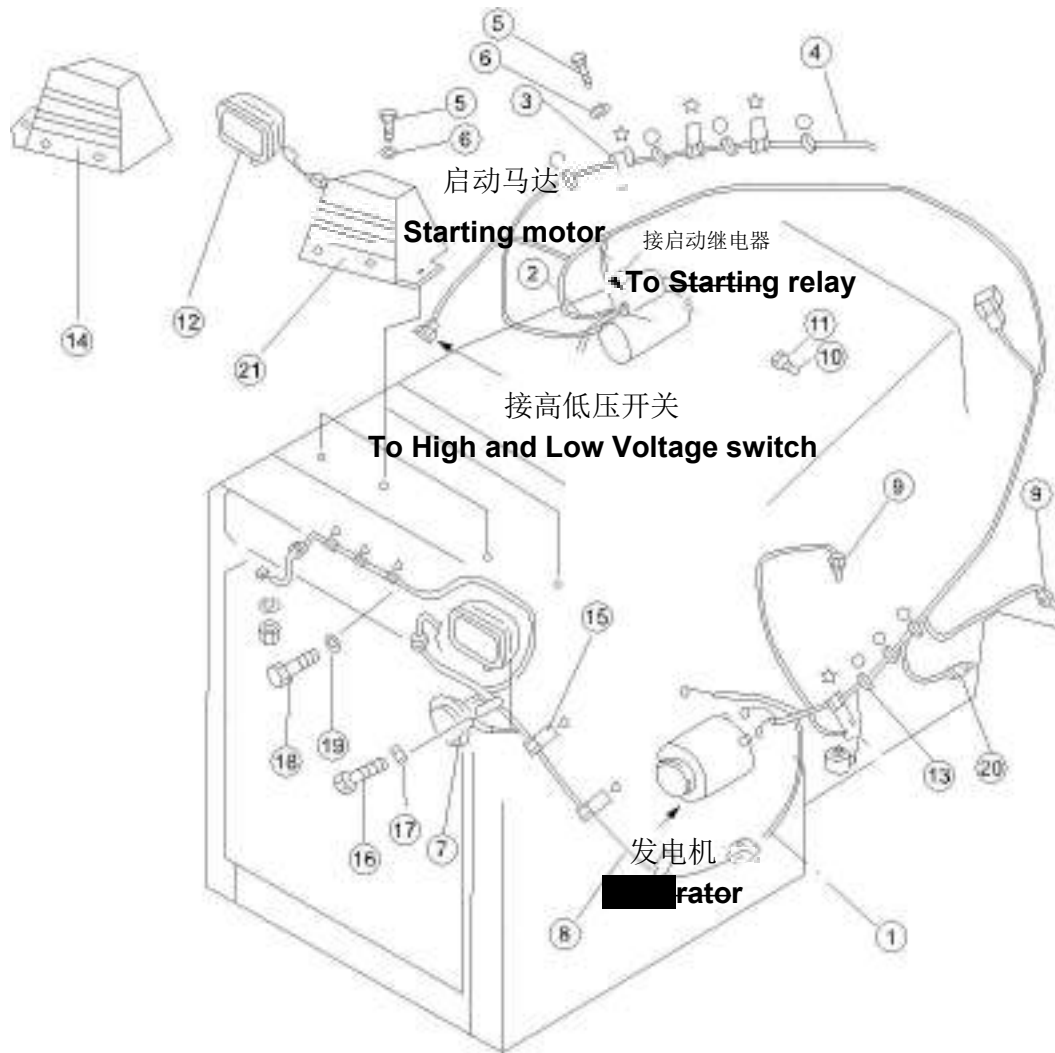

零件图册 | 电气系统 (装 GPS)

序号 NO.	部件号 PART NO.	零件名称 PART NAME		数量 Q'TY	适用机型 MODEL
1	175-06-38561	支架	Bracket	1	
2	175-06-38810	支架	Bracket	1	
3	D2590-00820	行程开关	Stroke switch	1	
4	01010-51016	螺栓 M10*16	Bolt M10*16	14	
5	01643-31032	垫圈 10	Washer 10	14	
6	D2401-07040	灯	Lamp	2	
7	D2401-07000	工作灯	Working lamp	1	
8	16Y-07C-00008	支架	Bracket	1	
9	08035-11010	线夹	Wire clip	8	
10	08035-12510	线夹	Wire clip	1	
11	08035-11510	线夹	Wire clip	2	
12	08035-12010	线夹	Wire clip	3	
13	171-07-02000	地板架线束	Floor frame wiring harness	1	
14	23Y-07B-13000	灯罩 ( 右 )	Lamp cover (R.H.)	1	
15	08035-11014	线夹	Wire clip	6	
16	01010-50816	螺栓 M8*16	Bolt M8*16	1	
17	01643-30823	垫圈 8	Washer 8	1	
18	01010-51216	螺栓 M12*16	Bolt M12*16	6	
19	01643-31232	垫圈 12	Washer 12	6	
20	D2300-01000	压力传感器	Pressure sensor	1	
21	23Y-07B-12000	灯罩 ( 左 )	Lamp cover (L.H.)	1	

# 电气系统 (2/2) ELECTRICAL SYSTEM (2/2)

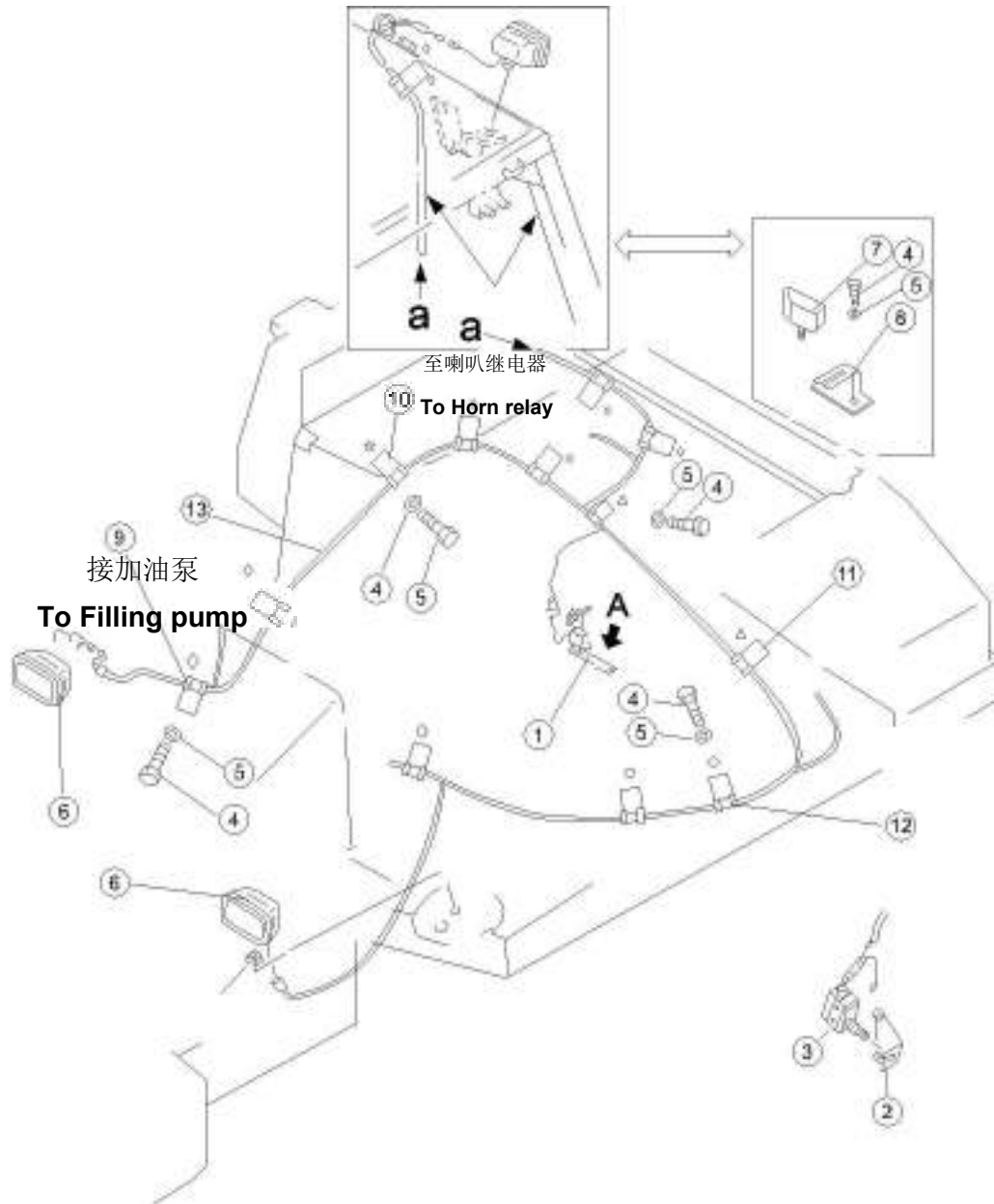

零件图册 | 电气系统 (装 GPS)

序号 NO.	部件号 PART NO.	零件名称 PART NAME		数量 Q'TY	适用机型 MODEL
1	175-06-38561	支架	Bracket	1	
2	175-06-38810	支架	Bracket	1	
3	D2590-00820	行程开关	Stroke switch	1	
4	01010-51016	螺栓 M10*16	Bolt M10*16	14	
5	01643-31032	垫圈 10	Washer 10	14	
6	D2401-07040	灯	Lamp	2	
7	D2401-07000	工作灯	Working lamp	1	
8	16Y-07C-00008	支架	Bracket	1	
9	08035-11010	线夹	Wire clip	8	
10	08035-12510	线夹	Wire clip	1	
11	08035-11510	线夹	Wire clip	2	
12	08035-12010	线夹	Wire clip	3	
13	171-07-02000	地板架线束	Floor frame wiring harness	1	

# 仪表箱 METER BOX

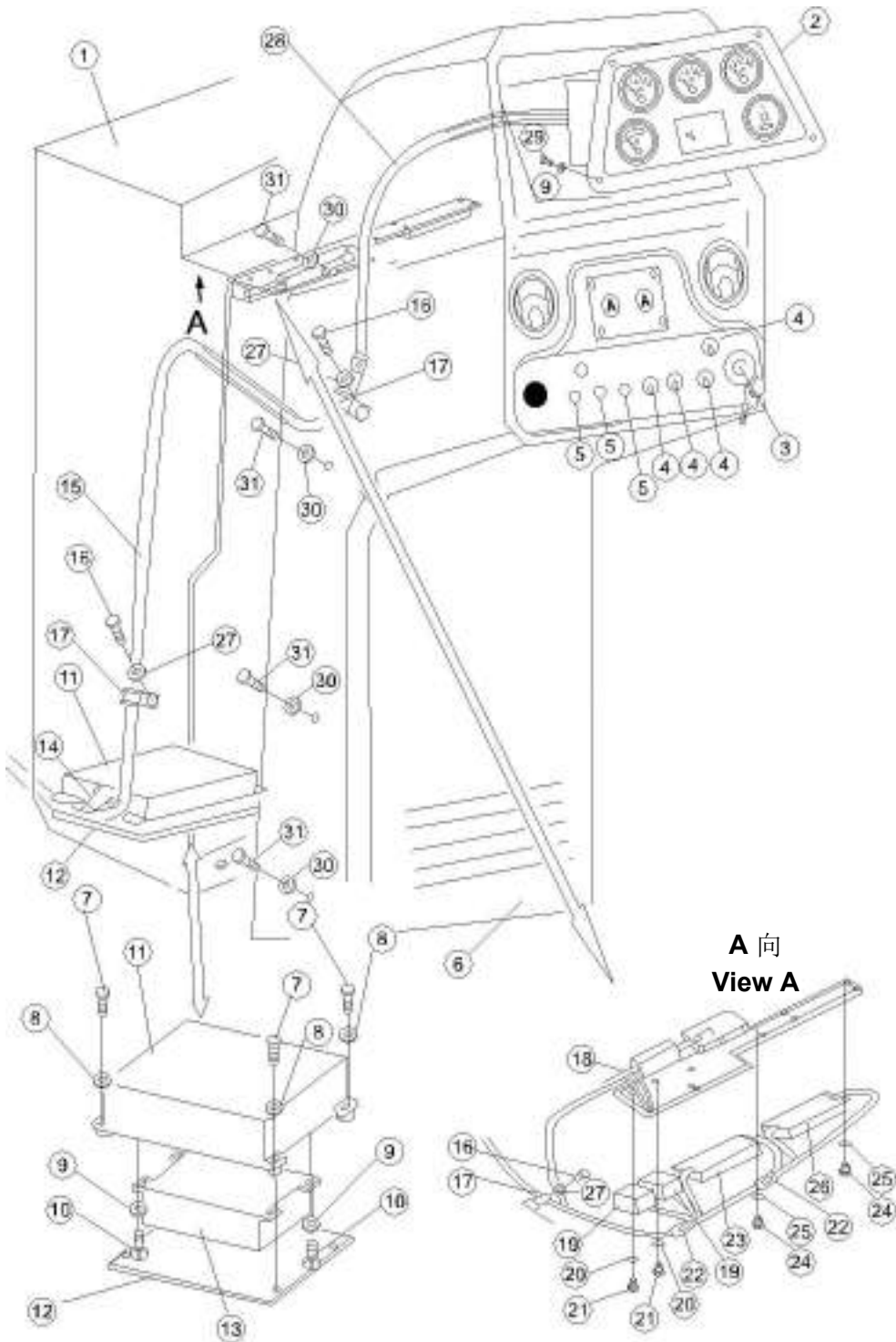

零件图册 | 电气系统 (装 GPS)

序号 NO.	部件号 PART NO.	零件名称 PART NAME		数量 Q'TY	适用机型 MODEL
1	171-07-07000	箱体	Box body	1	
2	D2210-00090	组合仪表	Combination meter	1	
3	D2500-00000	启动开关	Start switch	1	
4	D2530-01500	开关	Switch	4	
5	D2510-00200	按钮开关	Button switch	3	
6	23Y-91B-01000	仪表台	Meter platform	1	
7	01010-50820	螺栓 M8*20	Bolt M8*20	4	
8	01643-30823	垫圈 8	Washer 8	4	
9	01641-20608	垫圈 6	Washer 6	8	
10	01252-70620	螺钉 M6*20	Screw M6*20	4	
11	171-07A-20000	盖	Cover	1	
12	171-07A-21000	底板	Bottom plate	1	
13	D2234-00200	GPS 智能控制器	GPS Intelligent controller	1	
14	08037-11025	环管	Ring tube	1	
15	171-07A-19000	仪表箱线束 (下)	Instrument Wiring harness (Lower)	1	
16	01010-51016	螺栓 M10*16	Bolt M10*16	3	
17	08035-12510	线夹	Wire clip	3	
18	08034-20414	箍	Clamp	2	
19	D2660-02020	通用继电器	Universal Relay	2	
20	01641-20508	垫圈 5	Washer 5	2	
21	01220-40512	螺钉 M5*12	Screw M5*12	2	
22	08034-20519	箍	Clamp	2	
23	D2261-01000	SENDERCAN	SENDERCAN	1	
24	01220-40312	螺钉 M3*12	Screw M3*12	8	
25	01641-20305	垫圈 3	Washer 3	8	
26	D2261-01010	智能单元	Intelligent unit	1	
27	01643-31032	垫圈 10	Washer 10	3	
28	23Y-07C-21000	仪表箱线束 (上)	Instrument Wiring harness (Upper)	1	
29	01220-40620	螺钉 M6*20	Screw M6*20	4	
30	01641-20812	垫圈 8	Washer 8	8	
31	01010-50825	螺栓 M8*25	Bolt M8*25	8	

## 继电器与保险盒 RELAY AND FUSE BOX

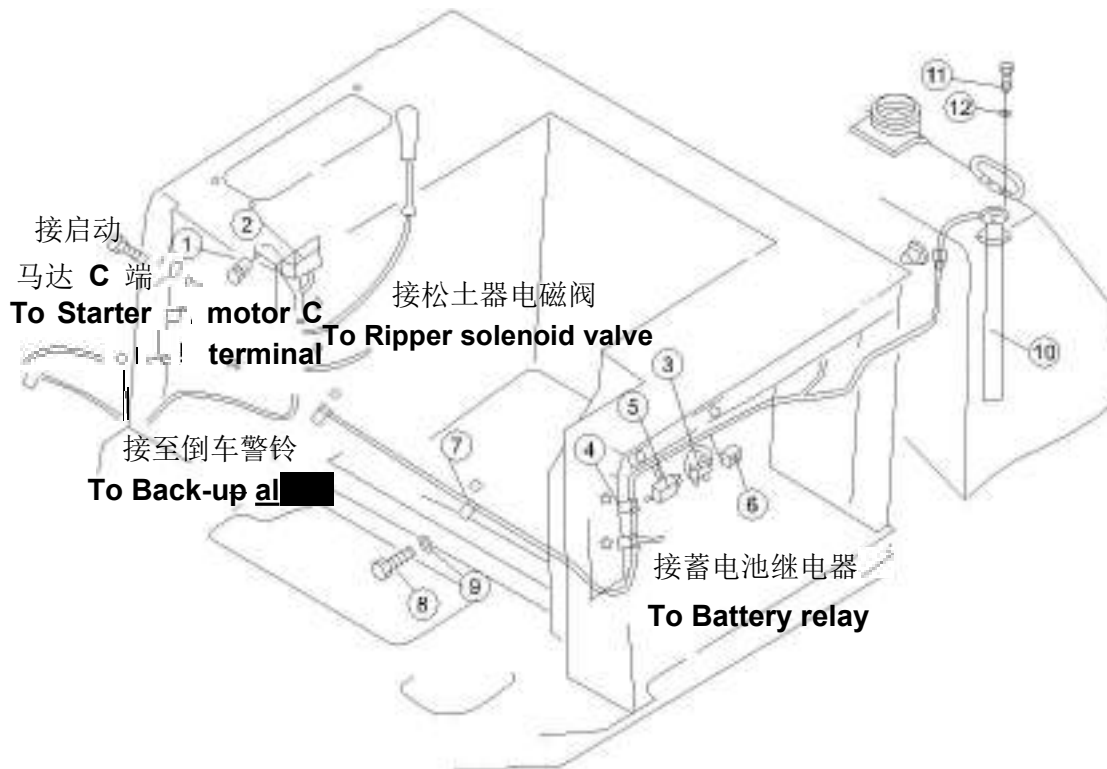

序号 NO.	部件号 PART NO.	零件名称 PART NAME		数量 Q'TY	适用机型 MODEL
1	D2510-00600	喇叭开关	Horn switch	1	
2	D2650-01100	喇叭继电器	Horn relay	1	
3	D1620-00000	电压继电器	Voltage relay	1	
4	08035-12010	线夹	Wire clip	2	
5	D2763-00900	保险丝盒	Fuse box	1	
6	D2660-02000	通用继电器	Universal Relay	1	
7	08035-11510	线夹	Wire clip	5	
8	01010-51016	螺栓 M10*16	Bolt M10*16	7	
9	01643-31032	垫圈 10	Washer 10	7	
10	D2331-71500	立式油位传感器	Vertical fuel level sensor	1	
11	01220-40516	螺钉 M5*16	Screw M5*16	5	
12	01641-20508	垫圈 5	Washer 5	5	

# 蓄电池与继电器 BATTERY AND RELAY

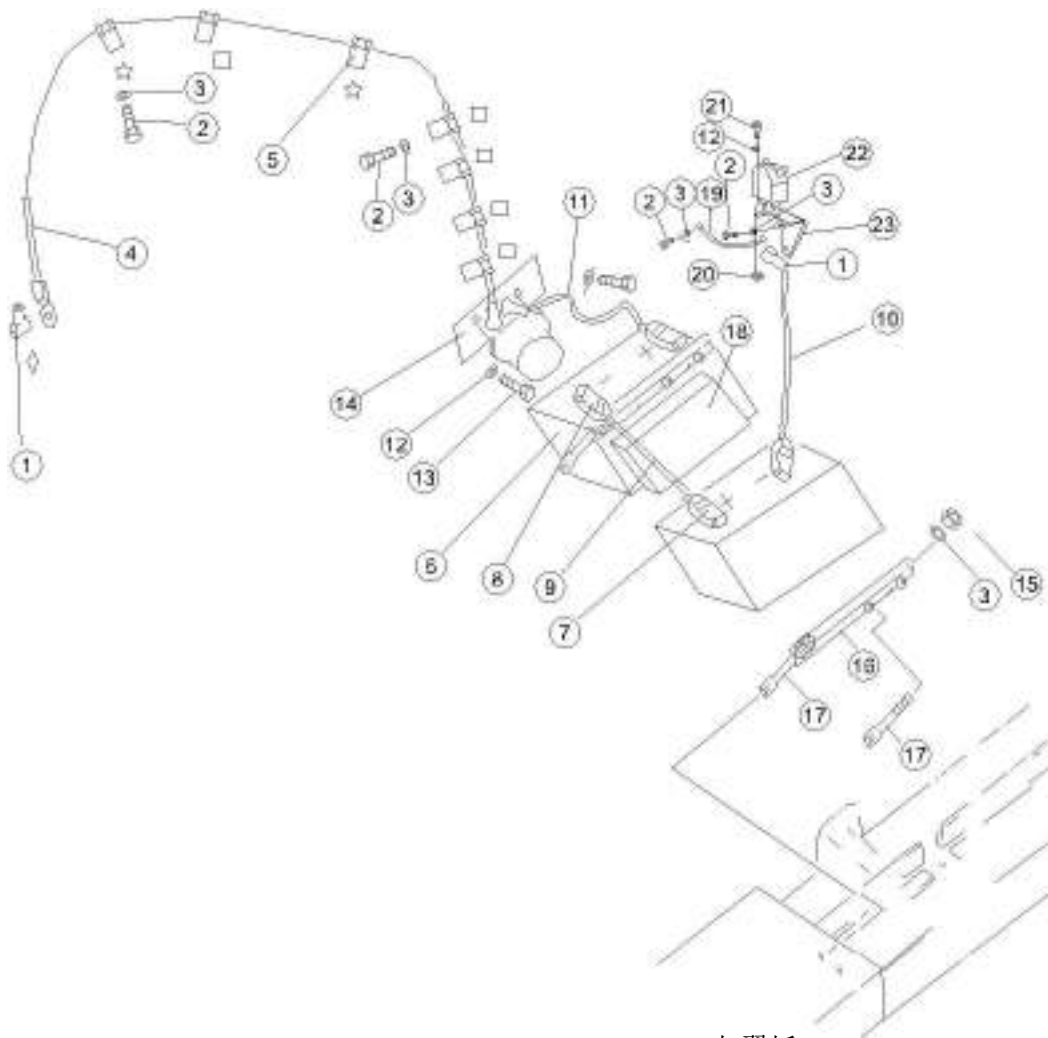

左翼板  
Fender L.H.

零件图册 | 电气系统 (装 GPS)

序号 NO.	部件号 PART NO.	零件名称 PART NAME	数量 Q'TY	适用机型 MODEL
1	08038-00035	罩 Cover	5	
2	01010-51016	螺栓 M10*16 Bolt M10*16	11	
3	01643-31032	垫圈 10 Washer 10	15	
4	171-07-01000	电缆 Cable	1	
5	08035-12510	线夹 Wire clip	2	
6	D1011-07500	电池 Battery	2	
7	D2000-00000	绝缘套 Insulating sleeve	2	
8	D2000-00001	绝缘套 Insulating sleeve	2	
9	171-07-13000	电缆 ( 蓄电池 + 至蓄电 池 - ) Cable (Battery+ To Battery-)	1	
10	171-07A-15000	电缆 Cable	1	
11	171-07-15000	电缆 ( 蓄电池 +- 继电器 ) Cable (Battery+-Relay)	1	
12	01643-30823	垫圈 8 Washer 8	4	
13	01010-50825	螺栓 M8*25 Bolt M8*25	2	
14	D2610-60000	蓄电池继电器 Battery relay	1	
15	01580-11008	螺母 M10 Nut M10	8	
16	121-07-16000	压板 Binder plate	2	
17	175-06-39621	拉杆 Lever	4	
18	171-07-00001	垫 Pad	1	
19	171-07A-14000	电缆 Cable	1	
20	01580-10806	螺母 M8 Nut M8	2	
21	01220-70820	螺钉 M8*20 Screw M8*20	2	
22	D2602-10010	蓄电池主开关 Battery main switch	1	
23	171-07A-00005	板 Plate	1	

A series of horizontal dashed lines for writing notes.

附属装置

**OPERATOR COMPARTMENT**

# 座椅及安装 OPERATOR'S SEAT

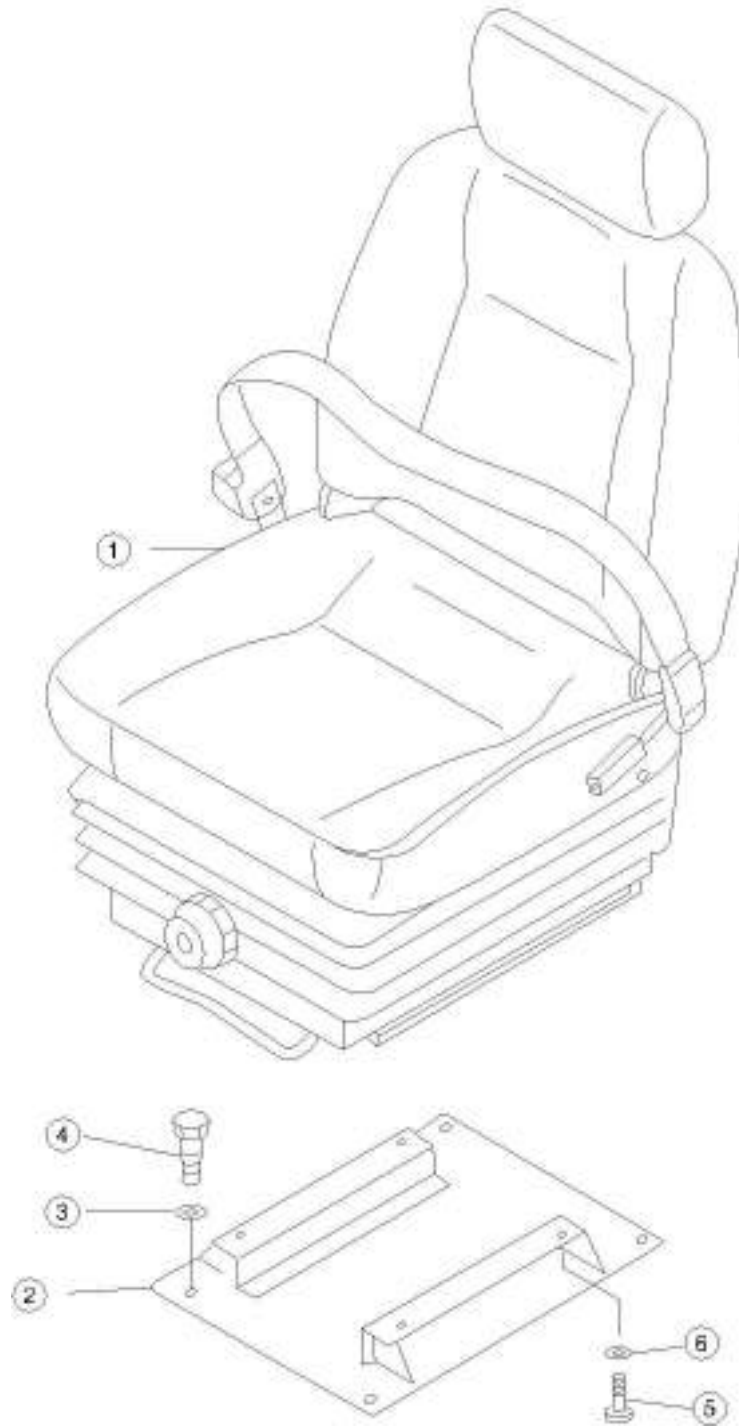

零件图册 | 附属装置

序号 NO.	部件号 PART NO.	零件名称 PART NAME	数量 Q'TY	适用机型 MODEL
1	23Y-53B-10000	座椅 Operator's seat	1	
2	171-53-01000	座 Seat	1	
3	01643-31232	垫圈 12 Washer 12	4	
4	01010-51225	螺栓 M12*25 Bolt M12*25	4	
5	01010-50825	螺栓 M8*25 Bolt M8*25	4	
6	01643-30823	垫圈 8 Washer 8	4	

# 防翻滚架 FRAME, ROPS

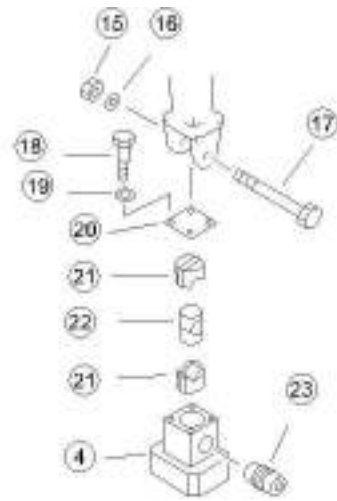
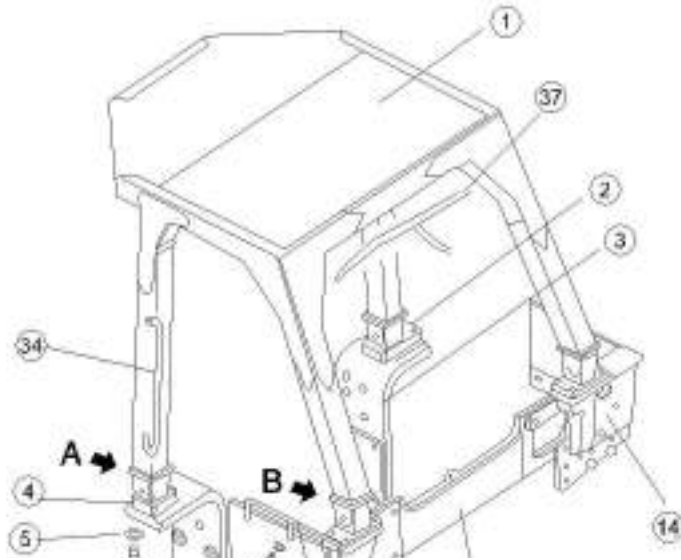

图示 A  
Detail A

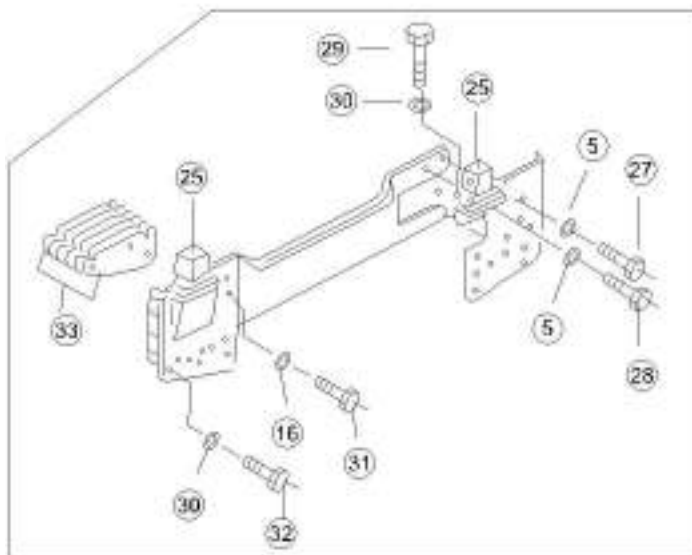

图示 B  
Detail B

序号 NO.	部件号 PART NO.	零件名称 PART NAME		数量 Q'TY	适用机型 MODEL
1	171-59-01000	防翻滚架	Frame, ROPS	1	
2	171-59-07000	托架 ( 右 )	Bracket (R.H.)	1	
3	171-59-05000	右支撑架	Support (R.H)	1	
4	171-59-06000	托架 ( 左 )	Bracket (L.H.)	1	
5	01643-33080	垫圈 30	Washer 30	10	
6	01011-53020	螺栓 M30*3*120	Bolt M30*3*120	8	
7	171-59-04000	左支撑架	Support (L.H)	1	
8	01011-53310	螺栓 M33*3*110	Bolt M33*3*110	8	
9	01643-33380	垫圈 33	Washer 33	10	
10	01010-51860	螺栓 M18*60	Bolt M18*60	8	
11	01643-31845	垫圈 18	Washer 18	8	
12	171-59-09000	左护板	Guard plate (L.H.)	1	
13	171-59-02000	护板	Guard plate	1	
14	171-59-03000	右护板	Guard plate (R.H.)	1	
15	01580-12722	螺母 M27	Nut M27	4	
16	01643-32780	垫圈 27	Washer 27	8	
17	175-978-5210	螺栓	Bolt	4	
18	01010-51230	螺栓 M12*30	Bolt M12*30	26	
19	01643-31232	垫圈 12	Washer 12	26	
20	195-56-11320	板	Plate	4	
21	154-54-42220	橡胶缓冲垫	Rubber cushion	8	
22	195-54-45490	块	Block	4	
23	195-54-45510	轴环	Shaft ring	4	
24	171-59-00001	座	Seat	2	
25	171-59-08000	托架	Bracket	2	
26	175-978-1260	调整垫	Adjusting gasket	2	
27	01011-53325	螺栓 M33*3*125	Bolt M33*3*125	1	
28	01010-53385	螺栓 M33*3*85	Bolt M33*3*85	1	
29	01010-52465	螺栓 M24*65	Bolt M24*65	8	
30	01643-32460	垫圈 24	Washer 24	20	
31	01010-52770	螺栓 M27*70	Bolt M27*70	4	
32	01010-52470	螺栓 M24*70	Bolt M24*70	12	
33	175-978-1232	垫片	Shim	12	
34	09420-01907	扶手	Armrest	2	
35	175-978-1270	把手	Handle	2	
36	175-978-1250	调整垫	Adjusting gasket	2	
37	171-59-10000	棚后灯线束	Wiring harness, Rear lamp	1	

# 驾驶室 CAB

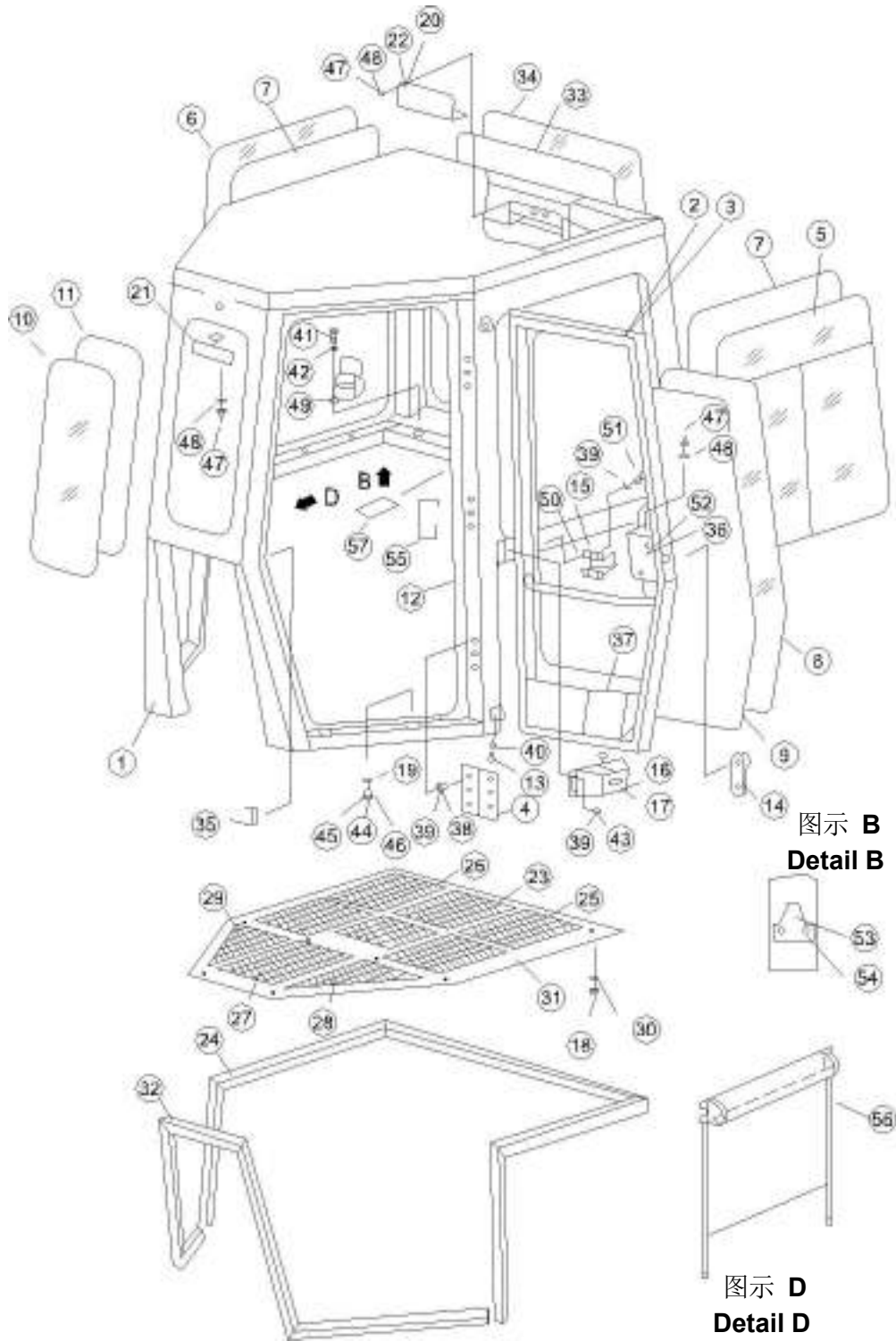

图示 B  
Detail B

图示 D  
Detail D

序号 NO.	部件号 PART NO.	零件名称 PART NAME		数量 Q'TY	适用机型 MODEL
1	171-56-01000	框架	Frame	1	
2	171-56-02000	门 ( 左 )	Door (L.H.)	1	
3	171-56-03000	门 ( 右 )	Door (R.H.)	1	
4	16Y-56C-04000	铰链	Hinge	6	
5	171-56-05000	左窗	Window (L.H.)	1	
6	171-56-04000	右窗	Window (R.H.)	1	
7	171-56-11000	玻璃镶条	Gib, glass	2	
8	171-56-00002	玻璃	Glass	2	
9	171-56-10000	玻璃镶条	Gib, glass	2	
10	171-56-00005	玻璃	Glass	1	
11	171-56-12000	镶条	Strip	1	
12	171-56-06000	密封条	Seal strip	2	
13	16Y-56C-08000	缓冲垫	Cushion	4	
14	23Y-56B-12000	锁总成	Lock ass'y	2	
15	171-56-14000	座板	Seat plate	2	
16	16Y-56C-11000	左碰锁	Latch (L.H.)	1	
17	16Y-56C-12000	右碰锁	Latch (R.H.)	1	
18	01210-50425	螺钉 M4*25	Screw M4*25	14	
19	16Y-56C-00003	盖	Cover	15	
20	171-56-00004	板	Plate	1	
21	16Y-56C-14000	后视镜	Rearview mirror	1	
22	171-56-09000	板	Plate	1	
23	171-56-00009	蜂窝海绵	Sponge	1	
24	171-56-00006	密封条	Seal strip	1	
25	171-56-00007	蜂窝海绵	Sponge	4	
26	171-56-00008	蜂窝海绵	Sponge	1	
27	171-56-00010	蜂窝海绵	Sponge	1	
28	171-56-00011	蜂窝海绵	Sponge	1	
29	171-56-00012	蜂窝海绵	Sponge	1	
30	23Y-57-00050	垫片	Shim	14	
31	171-56-08000	顶棚	Canopy	1	
32	171-56-00001	密封条	Seal strip	1	

# 驾驶室 CAB

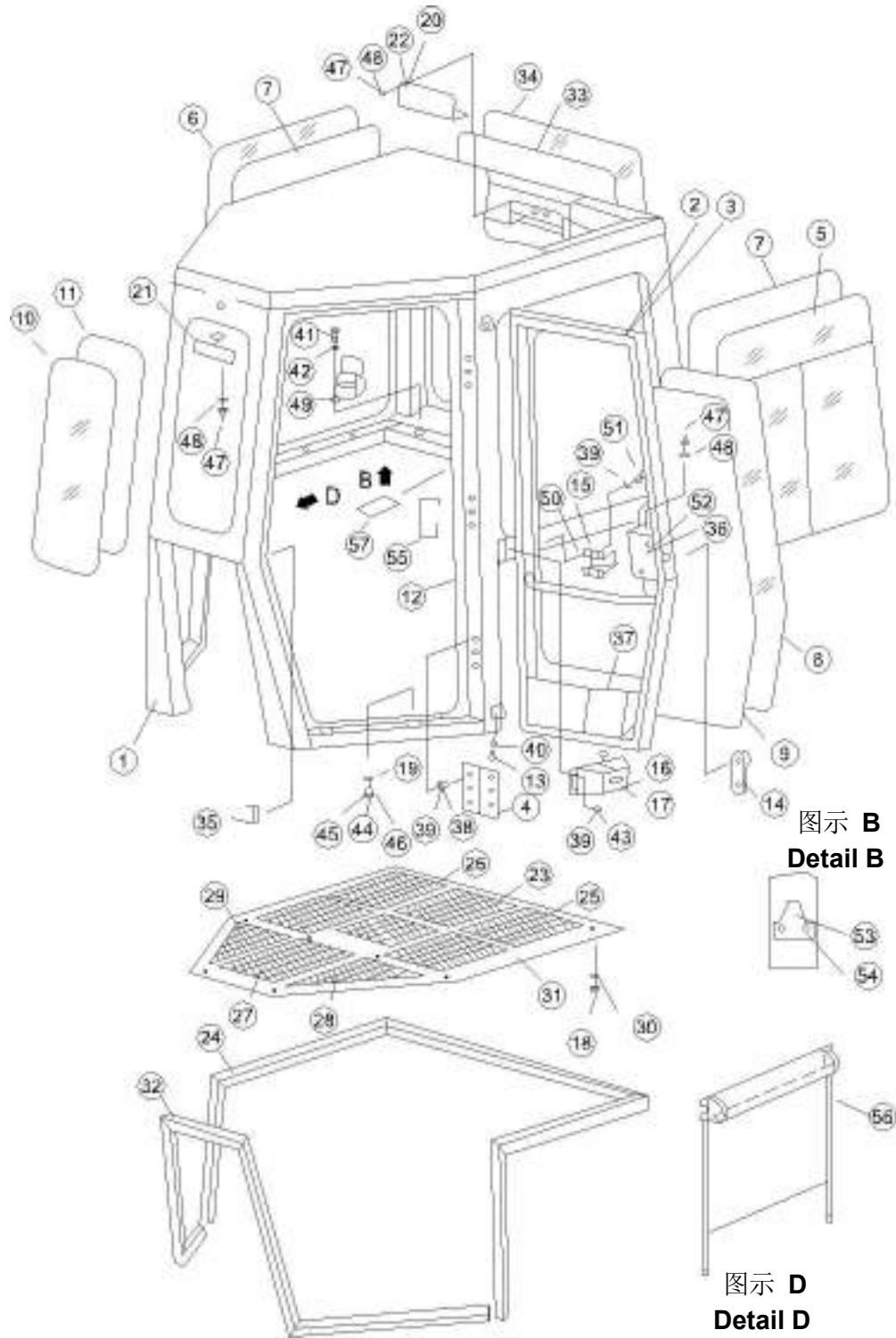

零件图册 | 附属装置

序号 NO.	部件号 PART NO.	零件名称 PART NAME	数量 Q'TY	适用机型 MODEL
33	171-56-13000	镶条 Strip	1	
34	171-56-00003	玻璃 Glass	1	
35	171-56-00013	板 Plate	2	
36	23Y-56B-00016	罩 Cover	1	
37	16Y-56C-00015	镶条 Strip	2	
38	01010-51040	螺栓 M10*40 Bolt M10*40	18	
39	01643-31032	垫圈 10 Washer 10	60	
40	01580-11008	螺母 M10 Nut M10	8	
41	01010-50816	螺栓 M8*16 Bolt M8*16	6	
42	01643-30823	垫圈 8 Washer 8	6	
43	01010-51020	螺栓 M10*20 Bolt M10*20	8	
44	01010-51460	螺栓 M14*60 Bolt M14*60	13	
45	01643-31445	垫圈 14 Washer 14	15	
46	01010-51435	螺栓 M14*35 Bolt M14*35	2	
47	01220-40612	螺钉 M6*12 Screw M6*12	14	
48	01641-20608	垫圈 6 Washer 6	22	
49	16Y-51C-19000	茶杯座 Seat, Teacup	1	
50	01573-20206	矩形座 Seat	4	
51	01010-51025	螺栓 M10*25 Bolt M10*25	26	
52	23Y-56B-00017	罩 Cover	1	
53	23Y-56B-00019	挂衣钩 Hook	1	
54	01214-50412	螺钉 M4*12 Screw M4*12	4	
55	171-56-00014	扶手 Armrest	2	
56	23Y-56B-17000	遮阳帘 Abat vent	1	
57	17S-79H-45000	座 Seat	2	

# 标牌涂装及运输图 MARKS AND PLATES

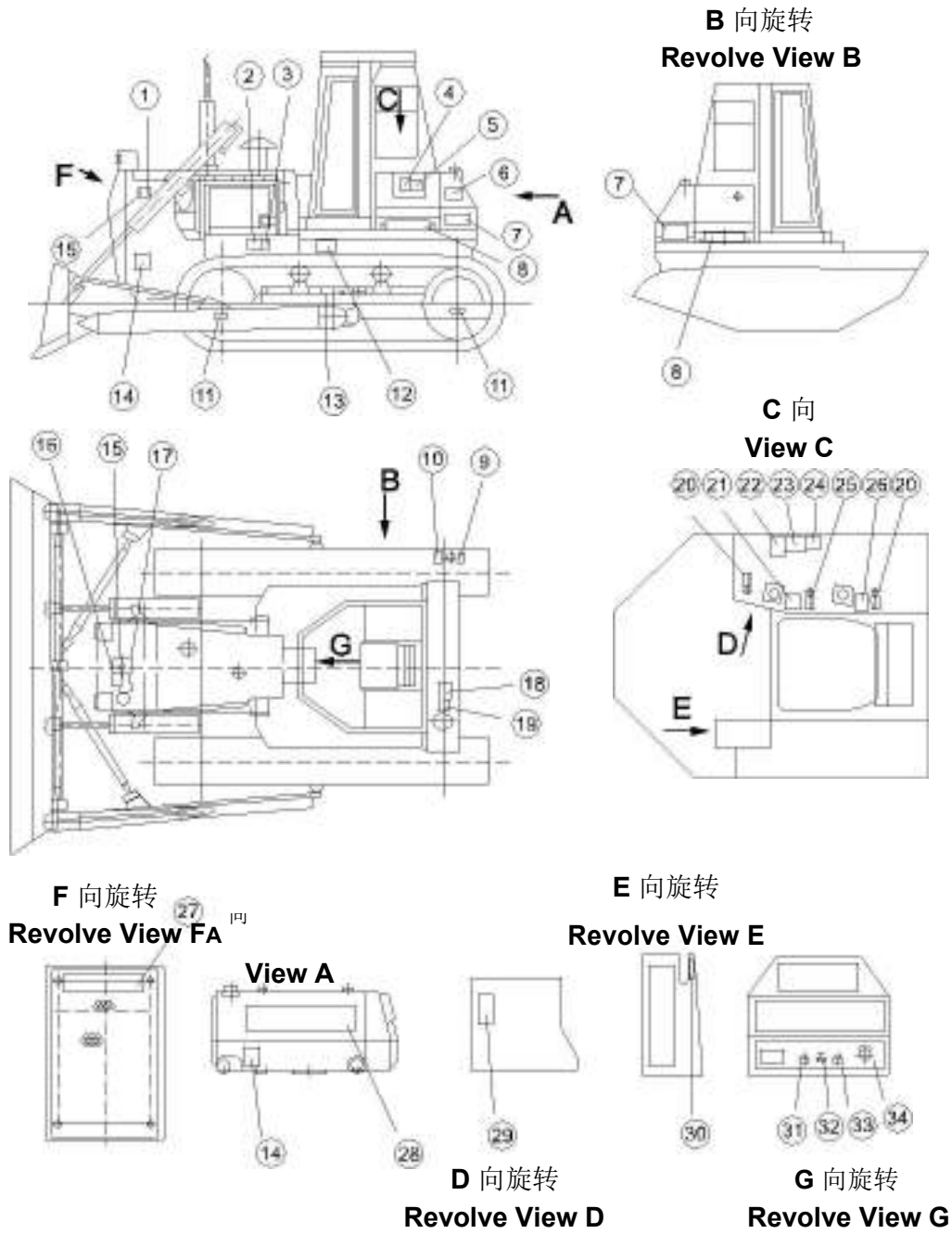

序号 NO.	部件号 PART NO.	零件名称 PART NAME	数量 Q'TY	适用机型 MODEL
1	09962-00100	铭牌 Nameplate	1	
2	09667-10880	标牌 Label plate	1	
3	09817-00880	标牌 Label plate	1	
4	09664-01000	标牌 Label plate	1	
5	09808-01000	标牌 Label plate	1	
6	09961-00100	服务标牌 Label plate	1	
7	09964-13000	标牌 Label plate	2	
8	171-90-00001	标牌 Label plate	2	
9	09669-00003	铭牌 Nameplate	1	
10	09965-00100	工作油箱安全及使用标 牌 Label plate	1	
11	09960-01001	标牌 Label plate	4	
12	09963-00100	起吊位置标牌 Label plate	1	
13	09657-00100	履带调整安全牌 Label plate	2	
14	09806-00880	标牌 Label plate	3	
15	04418-03060	标牌铆钉 Rivet	8	
16	09669-00001	铭牌 Nameplate	1	
17	09966-00100	水箱散热器标牌 Label plate	1	
18	09656-90080	燃油箱过滤器标牌 Label plate	1	
19	09669-00002	铭牌 Nameplate	1	
20	10Y-90B-00002	标牌 Label plate	2	
21	09670-00001	铲刀操纵标牌 Label plate	1	
21	09670-00003	铲刀操纵标牌 Label plate	1	
22	09802-01000	标牌 Label plate	1	
23	09967-00100	标牌 Label plate	1	
23	09967-00200	标牌 Label plate	1	
24	09658-00100	冬季特别提示标牌 Label plate	1	
25	09679-02002	喇叭开关标牌 Label plate	1	
26	09671-31683	松土器操纵标牌 Label plate	1	
26	09671-35468	松土器操纵标牌 Label plate	1	
27	09690-10710	标牌 Label plate	1	
28	09692-10500	标牌 Label plate	1	
29	09685-00001	操纵杆锁定标牌 Label plate	1	
30	09685-00002	操纵杆锁定标牌 Label plate	1	
31	16Y-90C-00003	标牌 Label plate	1	
32	171-90-00002	标牌 Label plate	1	
33	10Y-90B-00004	标牌 Label plate	1	
34	09683-30070	起动标牌 Label plate	1	

## 集中润滑及履带自动涨紧系统 LUBRICATING AND TRACK RECOIL SYSTEM

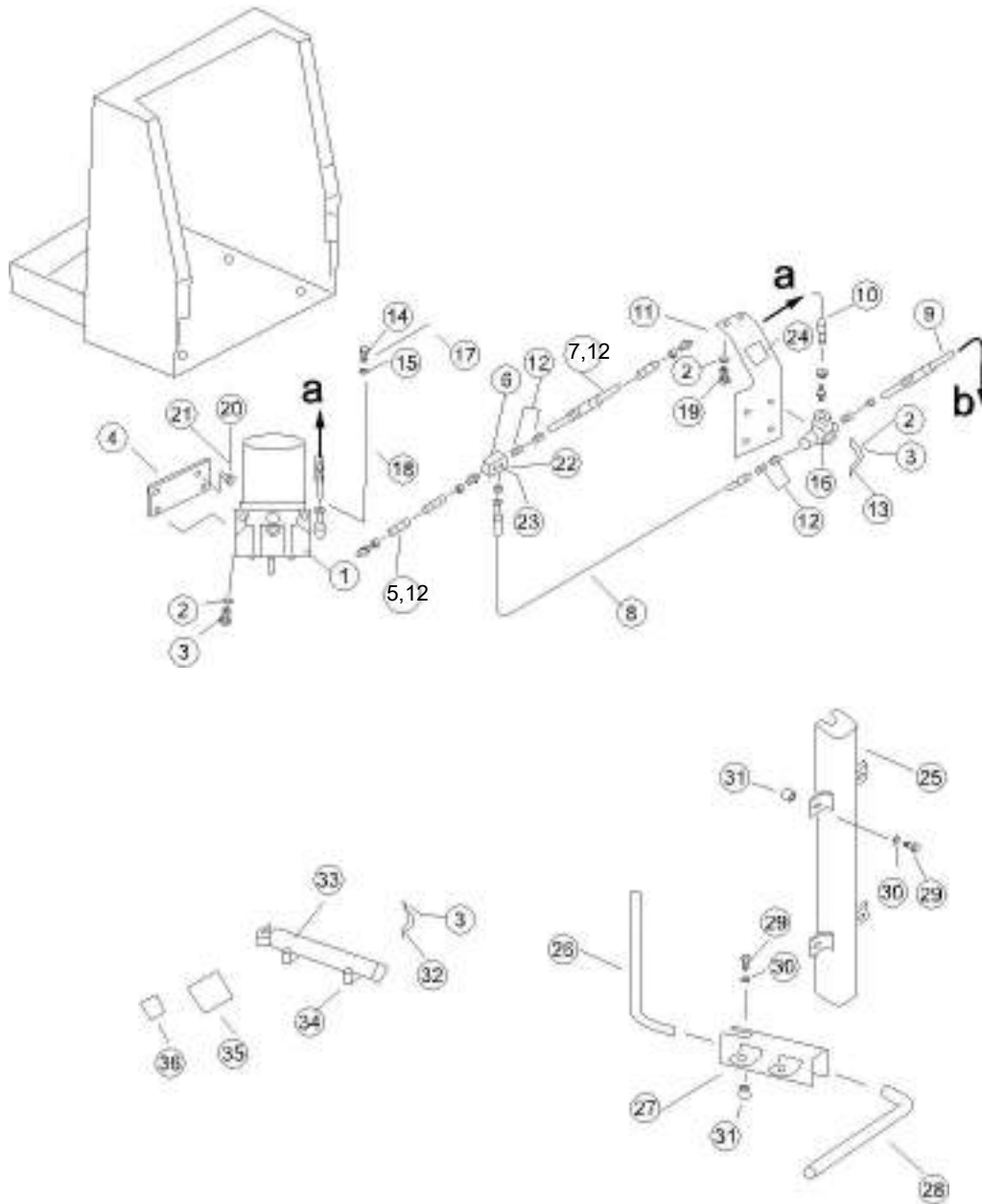

序号 NO.	部件号 PART NO.	零件名称 PART NAME		数量 Q'TY	适用机型 MODEL
1	17S-79H-08000	电动泵总成	Electric pump ass'y	1	
2	01643-30823	垫圈 8	Washer 8	8	
3	01010-50825	螺栓 M8*25	Bolt M8*25	7	
4	24Y-79-13000	板	Plate	1	
5	24Y-79-07000	软管总成	Hose ass'y	1	
6	17S-79H-15001	三通	Tee	1	
7	24Y-79-06000	软管总成	Hose ass'y	1	
8	17S-79H-06000	软管总成	Hose ass'y	1	
9	24Y-79-04000	软管总成	Hose ass'y	1	
10	17S-79H-07000	软管总成	Hose ass'y	1	
11	17S-79H-00004	板	Plate	1	
12	17S-79H-02000	直接头	Joint	9	
13	17S-79H-00003	管夹	Clip	2	
14	08061-50010	开关	Switch	1	
15	08040-00800	保险丝	Fuse	1	
16	17S-79H-03000	换向阀总成	Change valve ass'y	1	
17	17S-79H-04000	线束	Wiring harness	1	
18	17S-79H-05000	线束	Wiring harness	1	
19	01010-50816	螺栓 M8*16	Bolt M8*16	2	
20	01643-31032	垫圈 10	Washer 10	2	
21	01010-51025	螺栓 M10*25	Bolt M10*25	2	
22	01010-50630	螺栓 M6*30	Bole M6*30	2	
23	01643-30623	垫圈 6	Washer 6	2	
24	17S-79H-00005	操作指示标牌	Label plate	1	
25	17S-79H-16300	护罩	Guard	1	
26	17S-79H-16002	钢管	Steel tube	1	
27	23Y-79B-02100	护罩	Guard	1	
28	24Y-79-00003	硬管	Tube	2	
29	01010-51235	螺栓 M12*35	Bolt M12*35	4	
30	01643-31232	垫圈 12	Washer 12	4	
31	01571-01218	座	Seat	4	
32	17S-79H-00009	管夹	Clip	2	
33	17S-79H-44000	注油器	Grease fitting	1	
34	17S-79H-45000	座	Seat	2	
35	17S-79H-00010	警示牌	Warning plate	1	
36	17S-79H-00011	开关标牌	Label plate	1	

# 集中润滑及履带自动涨紧系统 LUBRICATING AND TRACK RECOIL SYSTEM

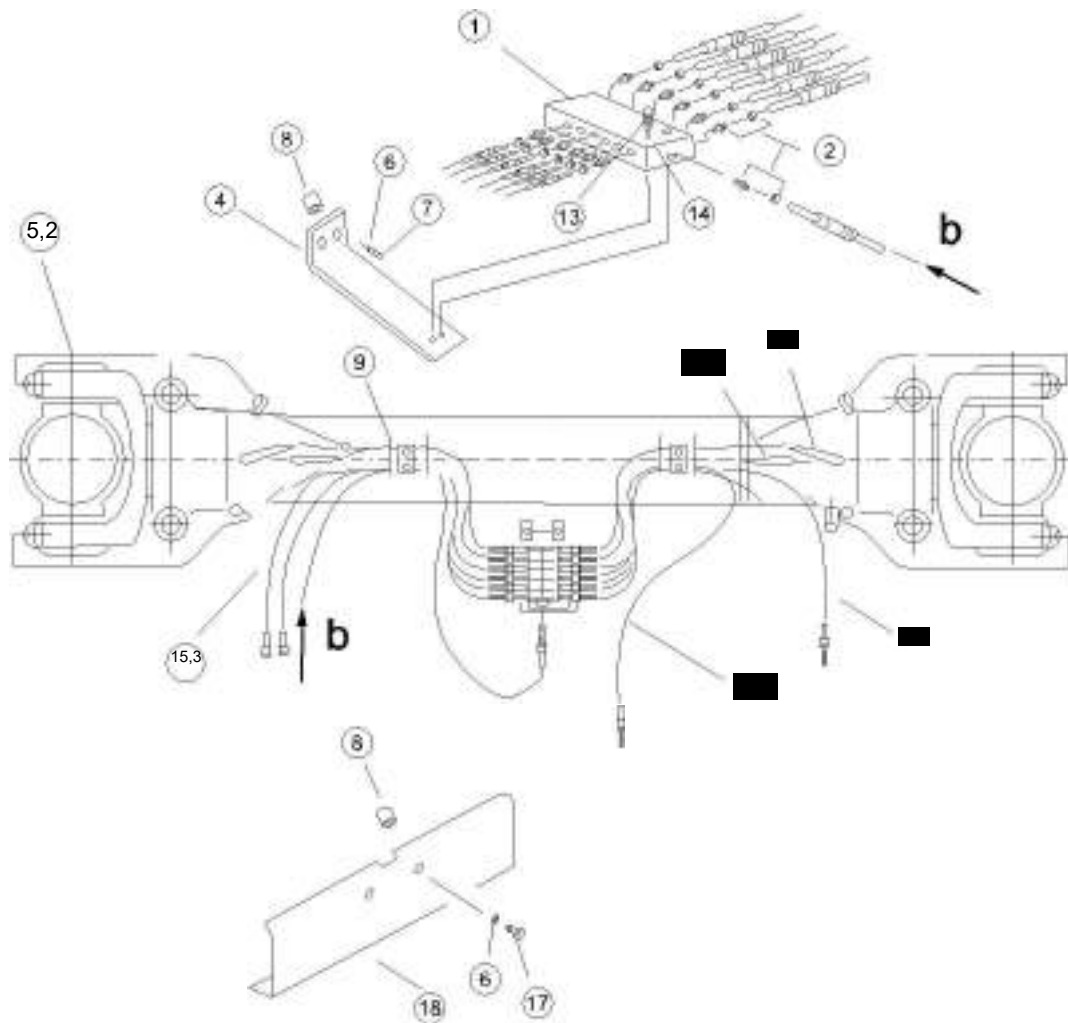

零件图册 | 附属装置

序号 NO.	部件号 PART NO.	零件名称 PART NAME		数量 Q'TY	适用机型 MODEL
1	17S-79H-12000	车体分配器	Body Distributor	1	
2	17S-79H-02000	直接头	Joint	19	
3	17S-79H-17000	直角接头	Joint	6	
4	17S-79H-00007	板	Plate	1	
5	24Y-79-12000	软管总成	Hose ass'y	4	
6	01640-21223	垫圈 12	Washer 12	4	
7	01010-51225	螺栓 M12*25	Bolt M12*25	2	
8	01571-01218	座	Seat	4	
9	08034-20519	箍	Clamp	10	
10	24Y-79-11000	软管总成	Hose ass'y	2	
11	24Y-79-10000	软管总成	Hose ass'y	2	
12	24Y-79-09000	软管总成	Hose ass'y	1	
13	01010-50630	螺栓 M6*30	Bole M6*30	2	
14	01643-30623	垫圈 6	Washer 6	2	
15	24Y-79-05000	软管总成	Hose ass'y	2	
16	24Y-79-08000	软管总成	Hose ass'y	1	
17	01010-51235	螺栓 M12*35	Bolt M12*35	2	
18	24Y-79-00002	护板	Guard plate	1	

