

**-驱动桥系统  
零部件图册**

**- DRIVE AXLE ASSEMBLY PARTS CATALOG**

**临工集团济南重机有限公司**

**LINGONG GROUP JINAN HEAVY MACHINERY CO., LTD.**

## **配件与服务Spare parts and services**

对于临工集团济南重机的机器所有者来说，只有临工集团济南重机配件和服务才能够使您的机器更好地保持原有的特性。

For the owner of the machines of LGMG,only the spare parts and services of LGMG can make your machine to better maintain the original features.

只有临工集团济南重机才能够为您提供完美匹配且优质纯正的配件和对您的机器了如指掌的专业维修人员。这样才能保证及其可持续的高产能和更长的使用寿命。

Only LGMG is able to provide you with the perfect match of pure quality spare parts for your machine and knowledge of professional maintenance staff.Only in this way it can ensure sustainable high productivity and longer service life.

### **-驱动桥系统零部件图册**

### **- DRIVE AXLE ASSEMBLY PARTS CATALOG**

2020年01月 第1版 第1次印刷

2020-1 Version 1 Printed 1

---

**临 工 集 团 济 南 重 机 有 限 公 司**  
**LINGONG GROUP JINAN HEAVY MACHINERY CO.,LTD.**

地址：中国·山东省济南市高新区科嘉路2676号

Add: 2676 Kejia Road, high tech Zone, Jinan City, Shandong Province

电话：86-0531-67601108

Tel: 86-0531-67601108

传真：86-0531-67601108

Fax: 86-0531-67601108

技术服务：86-0531-67605016

Web: WWW.LGMG.COM.CN

# 前 言

-驱动桥系统零部件图册，是为了方便用户使用、维修和保养而绘制的，以供在使用过程中查阅及参考，也可帮助用户了解本机的结构和装配关系。发动机的零部件详见其随机资料，图册不再绘出。

本图册按系统划分绘制出了各零部件的图形及相互装配关系。凡装机后不可拆卸的部件（如焊接件、铆合件），只标出部件代号，不另列其组成零件。本图册明细表采用中英文对照编排。

本图册根据-标准配置编绘，其它非标准配置，可参照执行，详情请咨询临工集团济南重机有限公司、或当地经销商、或登录临工集团济南重机有限公司网站查询。随着科技的进步，产品将会不断改进，故本图册的内容可能会有部分与以后的产品不一致，恕不另行通知。敬请用户在订购配件时，指明所购整车的出厂日期和编号。

编者

2020年1月

# FOREWORD

This parts catalog of - drive axle assembly is made for the convenience of users to use, repair and maintain the machine, which can be referred in the process of using. It can also help the users to be familiar with the structure and assembly relation of the machine. Parts of the engine are showed in details in its structure handbook, which are no longer contained in the catalog.

The catalog identifies drawings and assembly relations of different parts according to the system. Components which can not be taken apart, such as welding parts or riveted assemblies, are marked only by their code without the list of their consisting parts. The list in the catalog is arranged in Chinese and English.

This catalog is based on the - standard product, which can be a reference for the other nonstandard products, for more information, please consult LGMG, the local dealer or LinGong website. With the advancement of technology, we will keep on improving the product, so some content in the catalog may be inconsistent with the future products, which will not notice the users. When ordering the spare parts, please be kindly inform us the manufacturing date and serial number of the machine.

THE COMPILER  
2020.1



## 目录 CONTENTS

### E. 驱动桥系统 Drive axle assembly

E0800-4110001492014 后桥中段	
Middle part of rear bridge .....	4
E0800-4110001262003 后桥桥壳总成	
Axle housing assembly .....	8
E0800-4110001262004 后桥轮边总成	
1 .....	10
E0700-4110001261008 平衡悬架总成	
Balance suspension assembly .....	18
E0700-4110001261007 凸轮轴鼓式制动器总成	
Drum brake assembly .....	20



**E 驱动桥系统**  
**DRIVE AXLE ASSEMBLY**

**临工集团济南重机有限公司**

**LINGONG GROUP JINAN HEAVY MACHINERY CO., LTD.**

后桥中段 Middle part of rear bridge

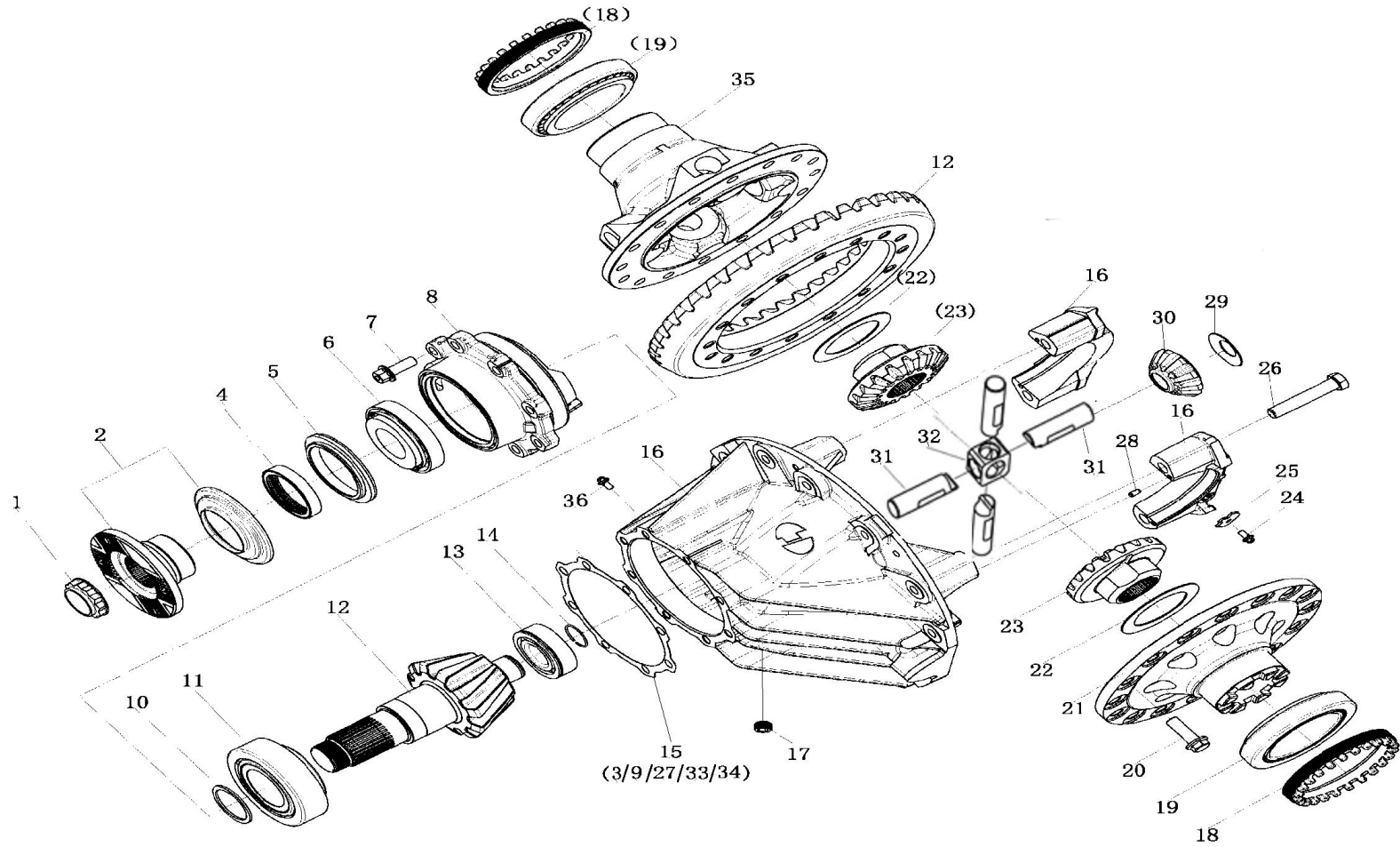

序号 Key	零件代号 Part No.	名称 Description	是否配件 Spare parts Y/N	数量 Qty	备注 Remarks
1	4110001187002	十二角螺母DZ95149320054	Y	1	
2	4110001188058	凸缘总成81.39115.5104	Y	1	
3	4110001721008	调整垫片HD469-2402021	Y	1	
4	4110001187004	主减油封DZ9112320920	Y	1	
5	4110001188003	油封座DZ9112320275	Y	1	
6	4021000030	滚动轴承GB297-31313	Y	1	
7	4110001187064	六角法兰面承面带齿螺栓-细牙Q1811645TF2	Y	8	
8	4110001188057	轴承座DZ90129320118	Y	1	
9	4110001721009	调整垫片HD469-2402022	Y	1	
10	4110001187076	调整垫片81.90770.0100	N	1	
11	4110001187068	圆锥滚子轴承HD469-2402100	Y	1	
12	4110001167003	主被动齿轮副HD90129321001	Y	1	
13	4110001187070	圆柱滚子轴承HD469-2402012	Y	1	
14	4110001187069	止推环HD469-2402055	Y	1	
15	4110001263003	调整垫片HD469-2402020-0.10	Y	1	
16	4110001188056	后桥主减速器总成HD90149326082	Y	1	
17	4110001187040	螺纹堵塞81.90310.0179	Y	1	
18	4110001187061	调整螺母81.35125.0024	Y	2	
19	4110001187073	轴承32024	Y	2	
20	4110001187058	六角法兰面承面带齿螺栓DZ90149326001	Y	16	
21	4110001492007	差速器壳（左）	Y	1	
22	4110001263005	半轴齿轮垫片HD95129320069-2.0	Y	2	

后桥中段 Middle part of rear bridge

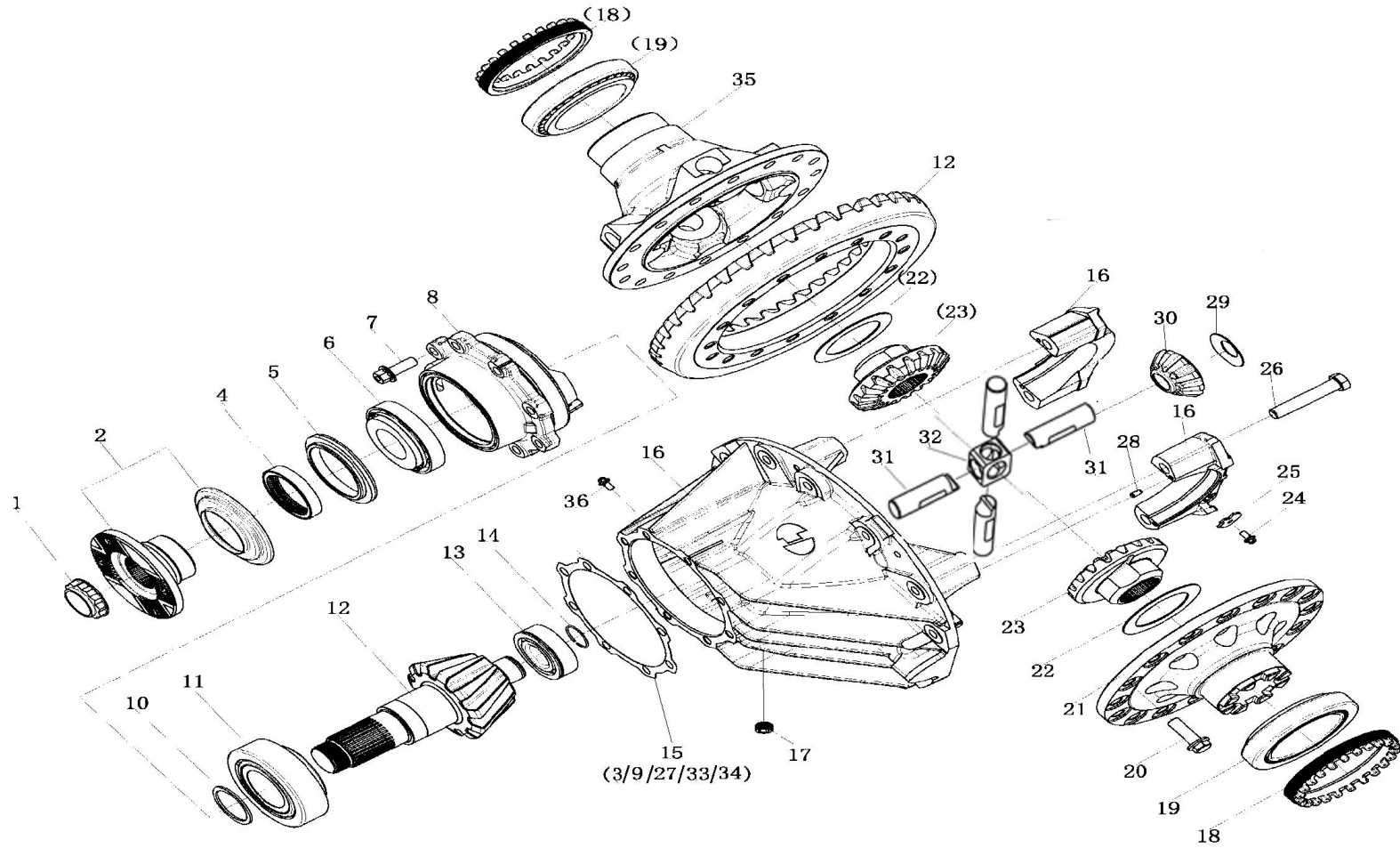

序号 Key	零件代号 Part No.	名称 Description	是否配件 Spare parts Y/N	数量 Qty	备注 Remarks
23	4110001492008	半轴齿轮	Y	2	
24	4110002028008	六角法兰面承面带齿螺栓Q1800816	Y	2	
25	4110001187059	锁止片DZ9112320028	Y	2	
26	4110001187152	瓦盖连接螺栓DZ90001500006	Y	4	
27	4110001721010	调整垫片HD469-2402023	Y	1	
28	4110001187048	圆柱销Q5220816	Y	4	
29	4110001187055	球面垫片HD95129320072	Y	4	
30	4110001492009	行星齿轮	Y	4	
31	4110001492010	十字轴	Y	4	
32	4110702806010	十字轴支座 HD90149326123	Y	1	
33	4110001721011	调整垫片HD469-2402024	Y	1	
34	4110001721012	调整垫片HD469-2402025	Y	1	
35	4110702806039	差速器壳（右） HD90149326118	Y	1	
36	4110001492013	标牌铆钉--铆钉GB827-86-2.5*6	Y	2	

后桥桥壳总成 Axle housing assembly

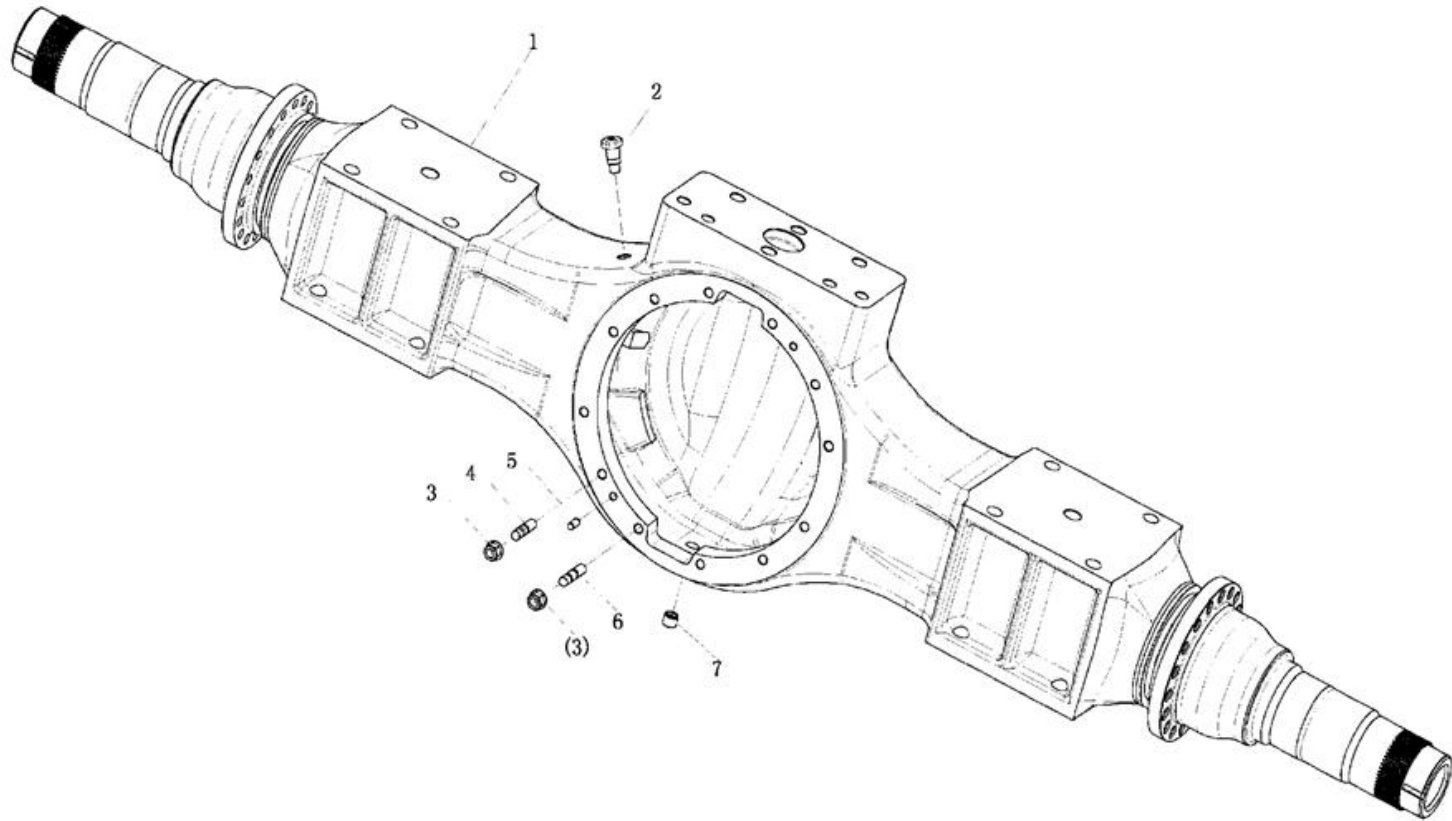



后桥轮边总成 1

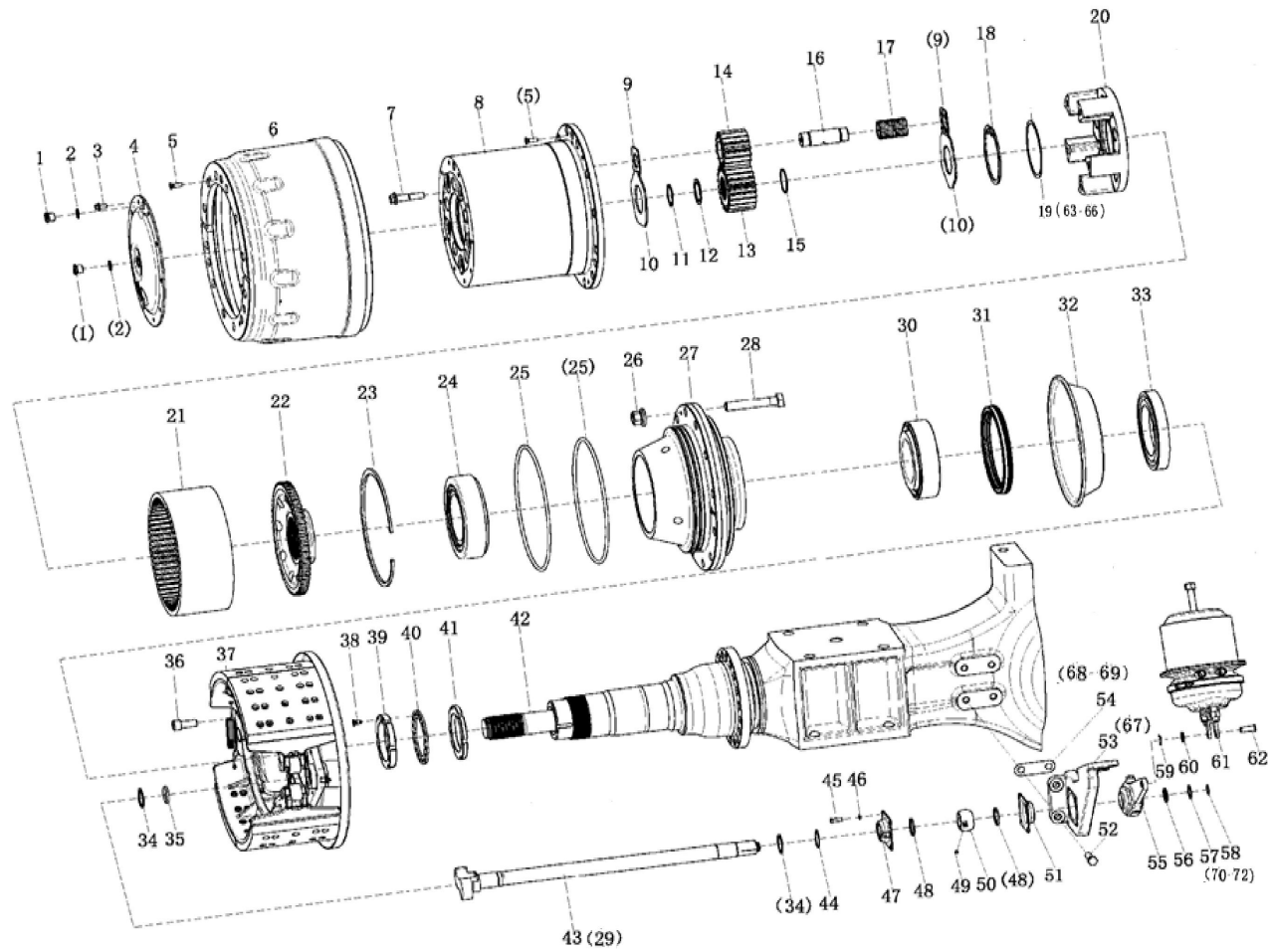

序号 Key	零件代号 Part No.	名称 Description	是否配件 Spare parts Y/N	数量 Qty	备注 Remarks
1	4110001187089	圆柱头内六角螺塞DZ9112346116	Y	1	
2	4110001187090	密封垫圈190003098026	Y	1	
3	4110001187088	六角法兰面螺栓Q184A1018TF2	Y	1	
4	4110001187087	端盖DZ9112342013	Y	1	
5	4110001182036	十字槽沉头螺钉Q2541030	Y	1	
6	4110001187111	制动鼓DZ90149346027	Y	1	
7	4110001360007	带齿面配合螺钉DZ9112342014	Y	1	
8	4110001261005	轮边减壳DZ90149346006	Y	1	
9	4110001187084	止推垫片DZ9112342041	Y	1	
10	4110001187085	太阳轮止推垫片DZ9112342025	Y	1	
11	4110001187095	轴用弹性挡圈Q43155	Y	1	
12	4110001187096	垫圈DZ90149346045	Y	1	
13	4110001187092	太阳轮DZ90149346013	Y	1	
14	4110001187086	行星齿轮DZ90149346012	Y	1	
15	4110001187093	轴用压扁钢丝挡圈Q43362	Y	1	
16	4110001162012	行星轮轴DZ90149346011	Y	1	
17	4110001162013	滚针总成DZ90149346009	Y	1	
18	4110001187094	孔用弹性挡圈160×4DIN472	Y	1	
19	4110001862131	调整垫片DZ9112342034	Y	1	
20	4110001261006	行星架DZ90149346007	Y	1	
21	4110001187103	内齿圈DZ90149346019	Y	1	
22	4110001188028	齿圈支架DZ90149346018	Y	1	

后桥轮边总成 1

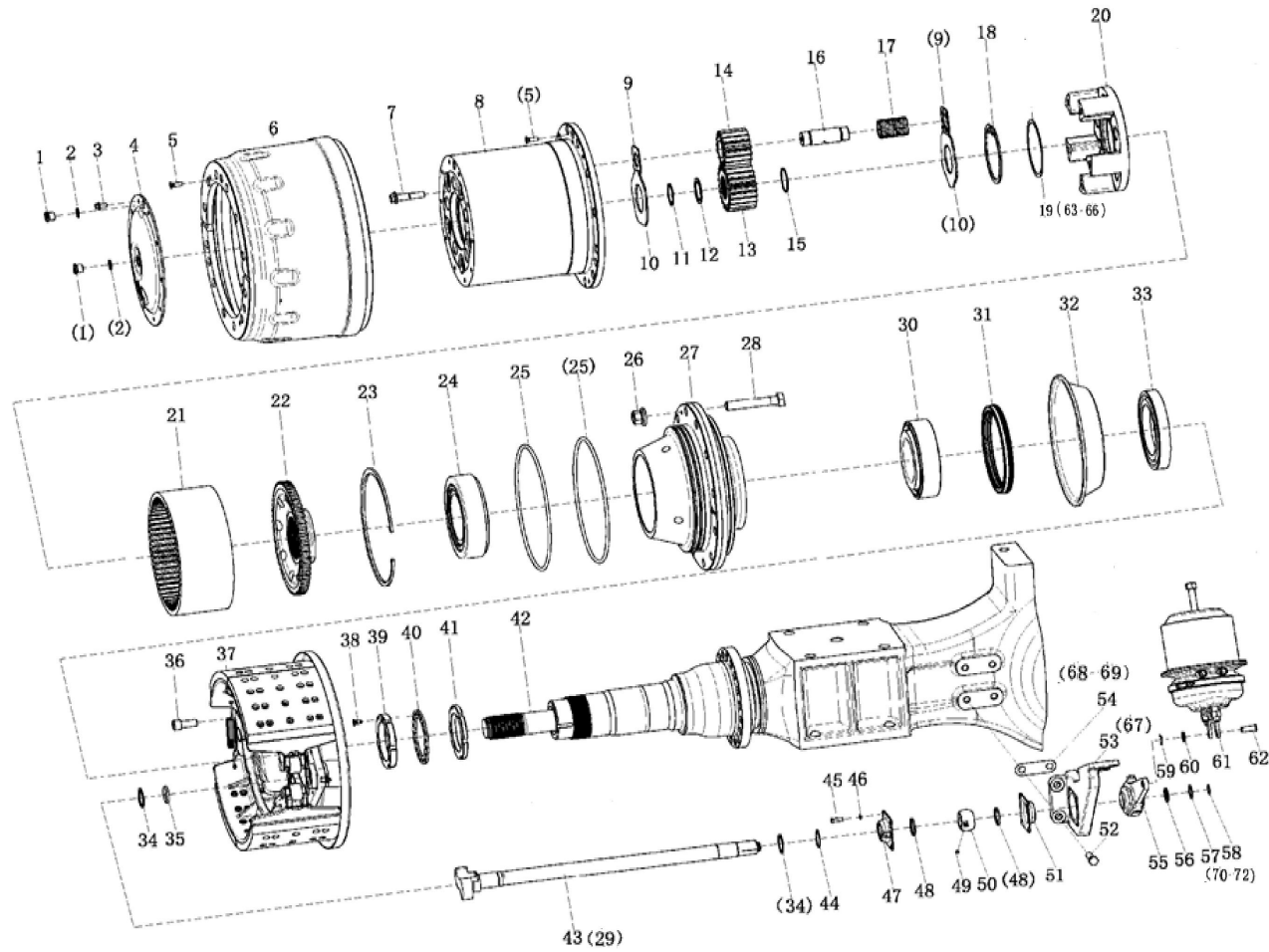

序号 Key	零件代号 Part No.	名称 Description	是否配件 Spare parts Y/N	数量 Qty	备注 Remarks
23	4110001187102	孔用弹性挡圈DZ9112342091	Y	1	
24	4110001187105	圆锥滚子轴承32226	Y	1	
25	4110001187083	O型密封圈DZ9112342061	Y	1	
26	4110001182005	车轮组合螺母DZ90149346075	Y	1	
27	4110001187104	轮毂DZ90149346020	Y	1	
28	4110001187108	车轮螺栓H150A24139AGF2	Y	1	
29	4190002272	制动凸轮轴（左）HD90149346003	Y	1	
30	4021000038	滚动轴承GB297-32224	Y	1	
31	4110001187107	轮毂油封DZ90149346023	Y	1	
32	4110001187109	挡油罩DZ9112342052	Y	1	
33	4110001187110	隔圈DZ90149346026	Y	1	
34	4110001141010	垫片DZ9112440508	Y	1	
35	4110001141011	O型密封圈DZ9112440517	Y	1	
36	4110001187112	内六角螺栓DZ90001500004	Y	1	
37	4110001187114	制动器总成DZ90149346029	Y	1	
38	4110001187100	十字槽沉头螺钉DZ90149346004	Y	1	
39	4110001187099	锁紧螺母DZ90149346016	Y	1	
40	4110001187098	止推垫圈DZ90149346015	Y	1	
41	4110001187097	锁紧螺母DZ90149346014	Y	1	
42	4110001162016	半轴HD90149346002	Y	1	
43	4190002274	制动凸轮轴（右）HD90149346004	Y	1	
44	4110001182054	轴用弹性挡圈Q43142	Y	1	

后桥轮边总成 1

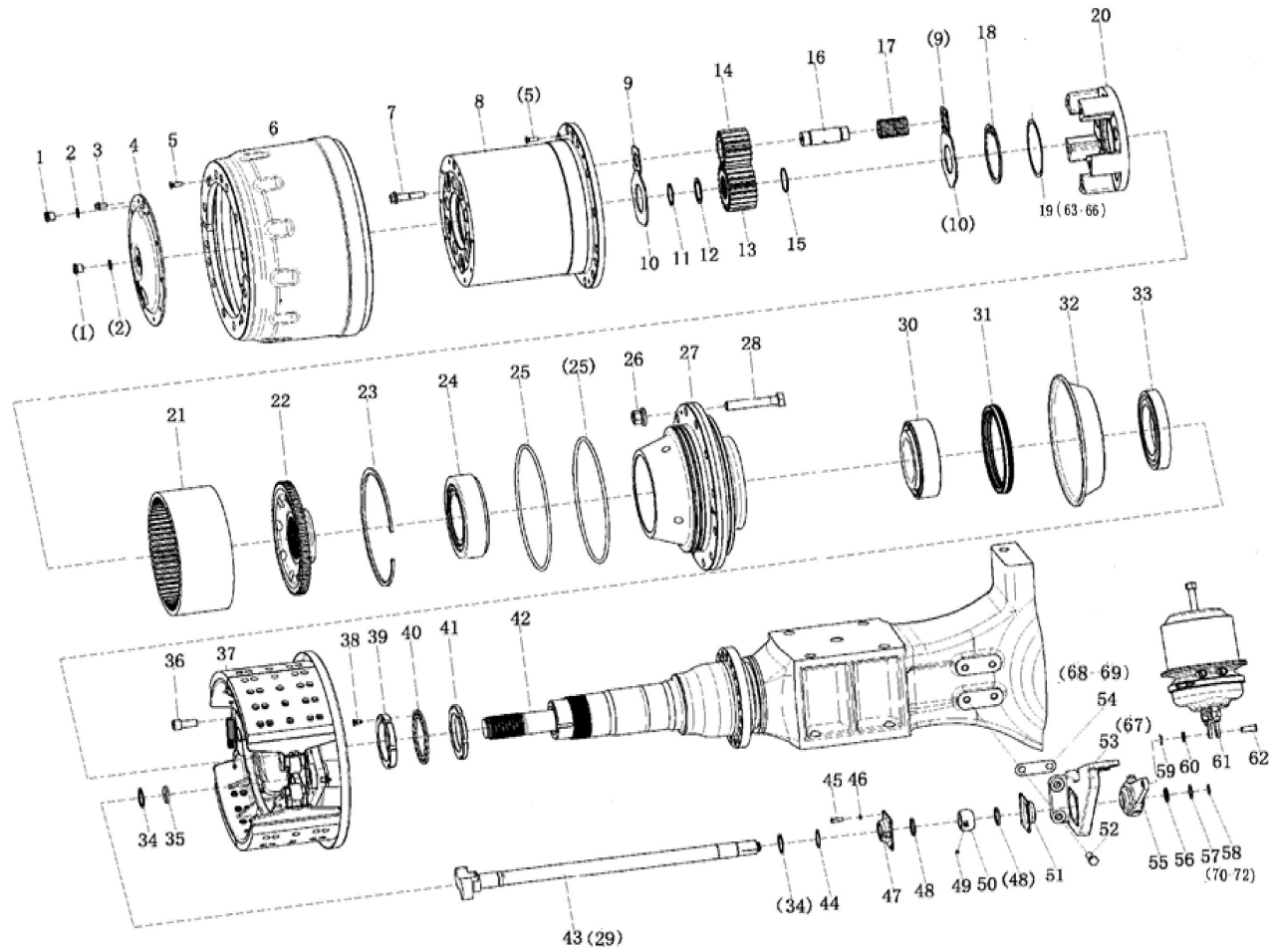

序号 Key	零件代号 Part No.	名称 Description	是否配件 Spare parts Y/N	数量 Qty	备注 Remarks
45	4110001182003	六角头螺栓Q150B0825	Y	1	
46	4110000342025	Q40308弹簧垫圈	N	1	
47	4110001187121	外球座DZ90149346063	Y	1	
48	4110001187122	油封DZ9112340093	Y	1	
49	4110001187125	滑脂嘴SXQ70006	Y	1	
50	4110001187124	球轴承DZ9112340095	Y	1	
51	4110001187126	内球座DZ90149346064	Y	1	
52	4110000819016	六角头螺栓-细牙Q151B1645TF2	Y	1	
53	4110001187129	气室支架（左）DZ90149346037	Y	1	
54	4110001187132	调整垫片DZ90149346042	Y	1	
55	4110001187131	间隙调整臂DZ90149346041	Y	1	
56	4110001182068	垫圈188000340022	Y	1	
57	4110001182066	调整垫圈108000320028	Y	1	
58	4110001182069	轴用弹性挡圈Q43125	Y	1	
59	4110001182074	开口销Q5004025	Y	1	
60	4110001182073	平垫圈Q40114	Y	1	
61	4110001182132	活塞式弹簧制动气室（36/30）HD90149366016	Y	1	
62	4110002028017	销轴190003903661	Y	1	
63	4110001862128	调整垫片DZ9112342031	Y	1	
64	4110001187091	调整垫片DZ9112342030	N	1	
65	4110001862129	调整垫片DZ9112342032	Y	1	
66	4110001862130	调整垫片DZ9112342033	Y	1	

后桥轮边总成 1

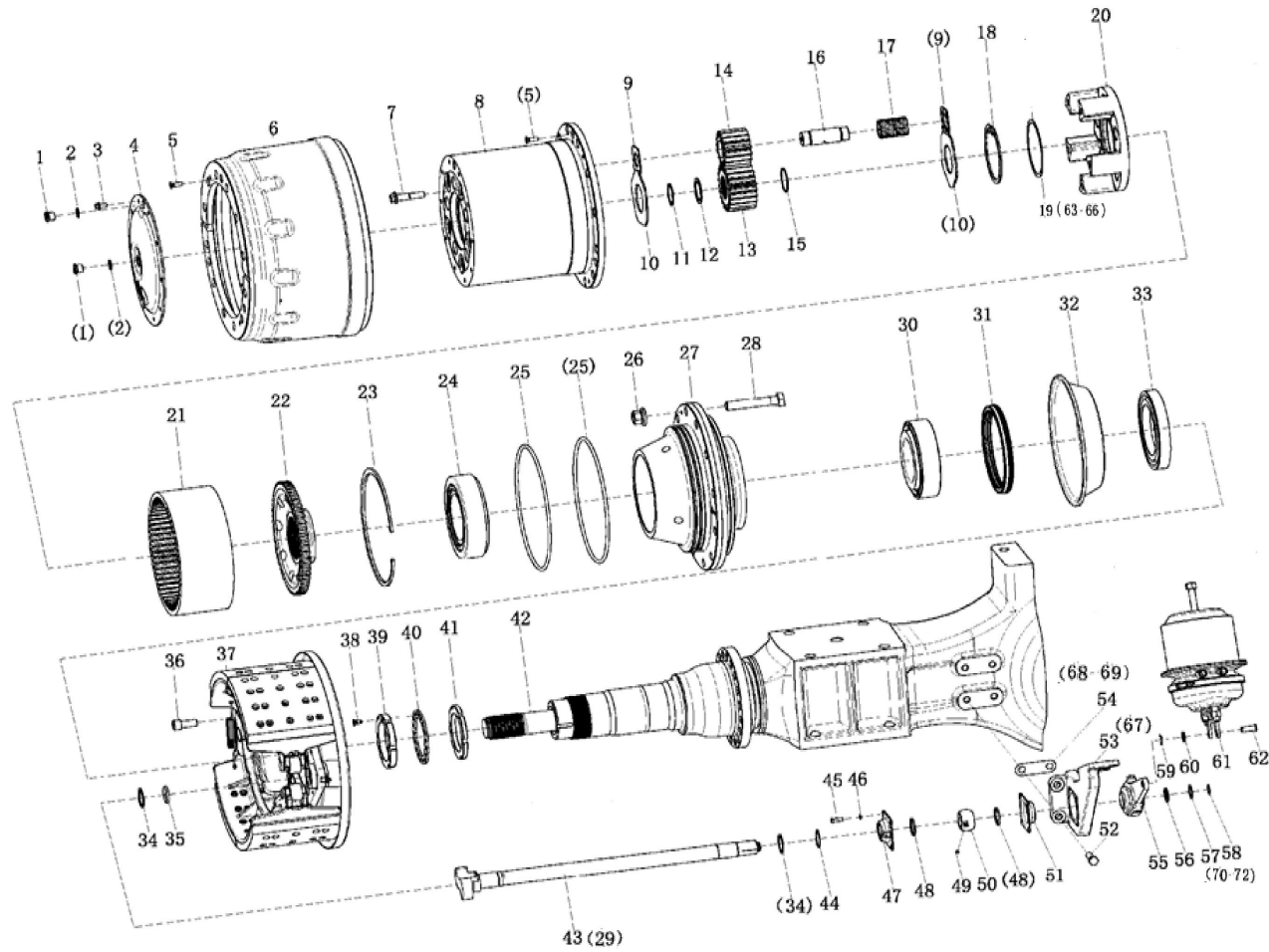

序号 Key	零件代号 Part No.	名称 Description	是否配件 Spare parts Y/N	数量 Qty	备注 Remarks
67	4110001187130	气室支架（右）DZ90149346038	Right brake rod	Y	1
68	4110002048011	调整垫片DZ90149346043	Adjuster washer	Y	1
69	4110002048012	调整垫片DZ90149346044	Adjuster washer	Y	1
70	4110001264011	调整垫片108000320028-0.15	Adjuster washer	Y	1
71	4110001182129	调整垫圈108000320030	Washer	Y	1
72	4110001182067	调整垫圈108000320046	Washer	Y	1

平衡悬架总成 Balance suspension assembly

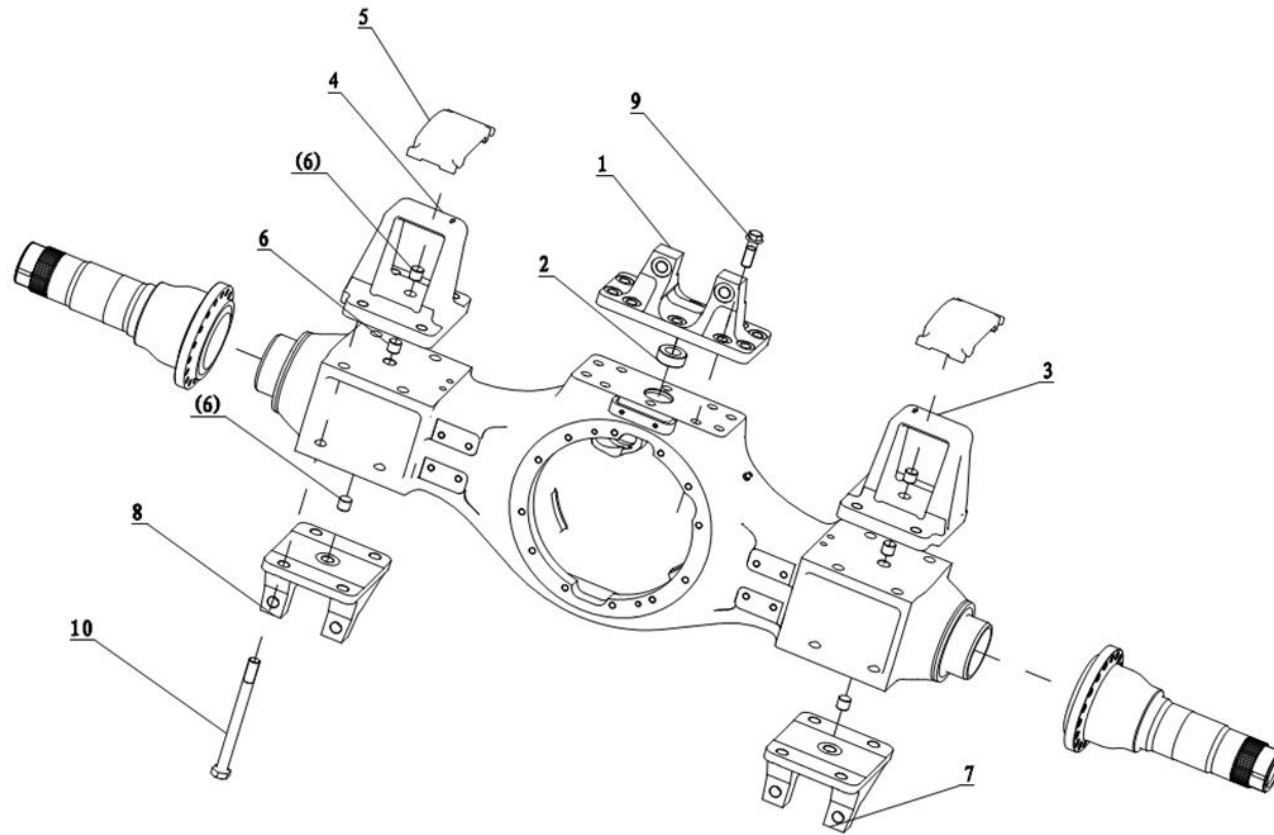

序号 Key	零件代号 Part No.	名称 Description	是否配件 Spare parts Y/N	数量 Qty	备注 Remarks
1	4110001259001	上推力杆支架HD90149526079	Y	1	
2	4110001187136	销子HD90149526005	Y	1	
3	4110001259002	停用-板簧支架(左)HD90149526077	Y	1	
4	4110001259003	停用-板簧支架(右)HD90149526078	Y	1	
5	4110001259004	板簧垫板HD90149526081	Y	2	
6	4110001187139	销子HD90149526014	Y	8	
7	4110001187140	下支架（左）HD90149526010	Y	1	
8	4110001187141	下支架（右）HD90149526011	Y	1	
9	4110001187142	六角法兰面螺栓HD90001500005	Y	10	
10	4110001261009	六角头螺栓-细牙Q151B24140TF2	Y	1	
11	4110001187143	六角头螺栓HD90001500004	Y	8	
12	4110001260001	上推力杆支架HD90149526080	Y	1	

凸轮轴鼓式制动器总成 Drum brake assembly

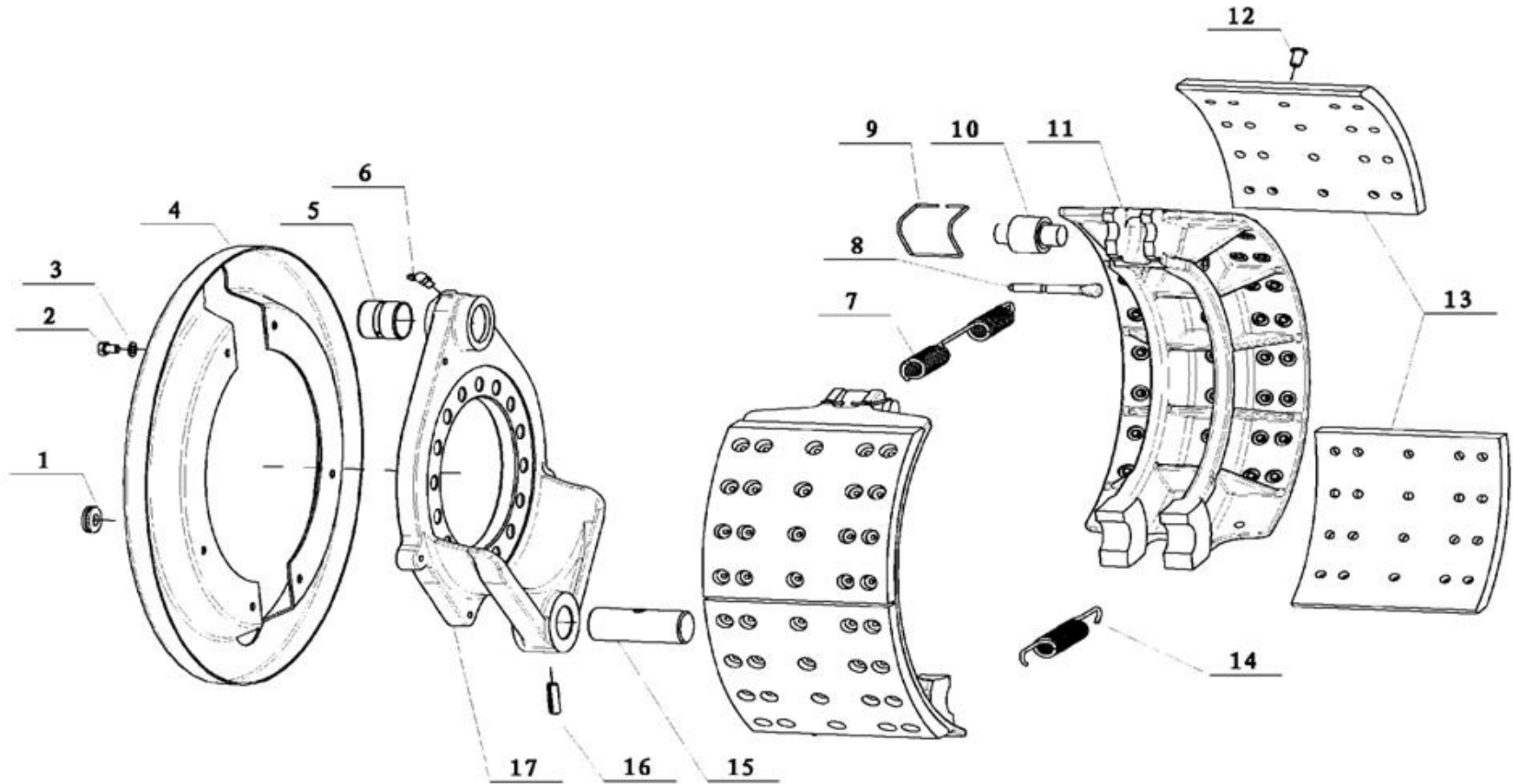

序号 Key	零件代号 Part No.	名称 Description	是否配件 Spare parts Y/N	数量 Qty	备注 Remarks
1	4110001182037	堵塞DZ9112440521	Y	2	
2	4110001862142	六角头螺栓Q150B1016	Y	6	
3	4110001182039	弹簧垫圈Q40310	Y	6	
4	4110001187116	防尘罩DZ90149346030	Y	1	
5	4110001182041	衬套DZ9112440507	Y	1	
6	4110001182022	米制锥螺纹滑脂嘴190003963114	Y	1	
7	4110001141009	回位弹簧DZ9112440524	Y	1	
8	4110001182042	回位弹簧销DZ9112440525	Y	2	
9	4110001182043	支撑弹簧DZ9112440526	Y	2	
10	4110001182044	滚轮轴DZ9112440527	Y	2	
11	4110001187117	制动蹄DZ90149346031	Y	1	
12	4110001182047	铆钉DZ90004400001	Y	40	
13	4110001187118	摩擦片DZ90149346032	Y	2	
14	4110001182048	下回位弹簧DZ9112440531	Y	2	
15	4110001182049	制动蹄销DZ9112440532	Y	1	
16	4110001182050	销DZ90005000000	Y	1	
17	4110001182051	制动底板DZ90149346025	Y	1	

